

**nifty**

# Heightrider

Operating & Safety Instructions

**MODEL HR15N (SP45N) SERIES**

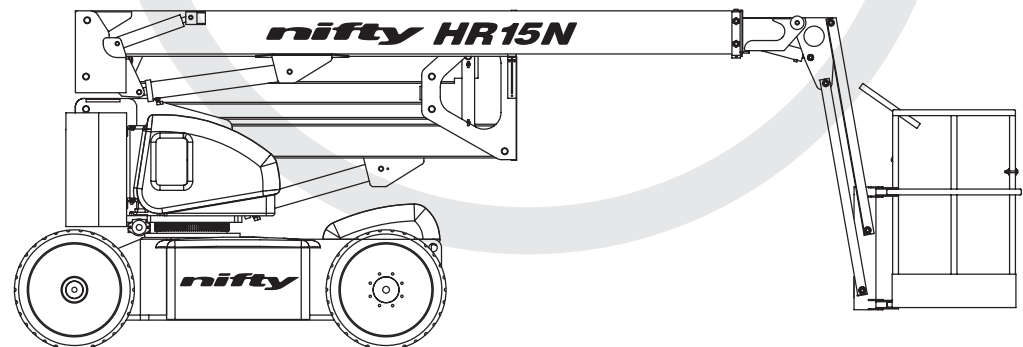

Manufactured by:  
**Niftylift Limited**  
Fingle Drive  
Stonebridge  
Milton Keynes  
MK13 0ER  
England

www.niftylift.com  
e-mail: info@niftylift.com  
Tel: +44 (0)1908 223456  
Fax: +44 (0)1908 312733



**niftylift.com**  
info@niftylift.com



# Table of Contents

<b>1.</b>	<b>INTRODUCTION AND GENERAL INFORMATION</b>	<b>PAGE</b>
1.1	Foreword	2
1.2	Scope	3
1.3	Introducing the “Height Rider” Self Propelled (SP) Series	3
1.4	General Specification	4
1.5	Identification	5-6
<b>2.</b>	<b>SAFETY</b>	
2.1	Mandatory Precautions	7-10
2.2	Environmental Limitations	10
2.3	Noise & Vibration	10
<b>3.</b>	<b>PREPARATION AND INSPECTION</b>	
3.1	Unpacking	11
3.2	Preparation for Use	11
3.3	Pre-Operational Safety Check Schedules	12
3.4	Placard, Decals and Installation	13-14
3.5	Torque Requirements	15
<b>4.</b>	<b>OPERATION</b>	
4.1	Control Circuit Components	16-18
4.2	Ground Control Operation	19-20
4.3	Platform Control Operation	21-22
4.4	Driving Controls	23
4.5	Batteries and Charging	24-25
4.6	Transporting, Towing, Storage and Setting to Work	26-27
<b>5.</b>	<b>EMERGENCY CONTROLS</b>	
5.1	General	28
5.2	Emergency Procedures - Incapacitated Operator	28
5.3	Emergency Procedures - Machine Failure	28
5.4	Incident Notification	28
<b>6.</b>	<b>RESPONSIBILITIES</b>	
6.1	Changes in Ownership	28
6.2	Manual of Responsibilities (USA only)	28
6.3	Inspection/ Service Check List	29-30

# 1. Introduction and General Information

## 1.1 FOREWORD

The purpose of these manuals is to provide the customer with appropriate safety operating and maintenance instructions essential for proper machine operation.

All information in these manuals should be **READ** and fully **UNDERSTOOD** before any attempt is made to operate the machine. **THESE MANUALS ARE VERY IMPORTANT TOOLS** - Keep them with the machine at all times.

**The manufacturer has no direct control over machine application and use, therefore conformance with good safety practices is the responsibility of the user and his operating personnel.**

**All information in these manuals is based on the use of the machine under proper operating conditions. Alteration and/or modification of the machine are strictly forbidden.**

**One of the most important facts to remember is that any equipment is only as safe as those who operate it.**

### **DANGER, WARNING, CAUTION, IMPORTANT, INSTRUCTIONS AND NOTICE**

Any place these topics may appear, either in this manual or on the machine, they are defined as follows:

**DANGER:** If not correctly followed there is a high probability of serious injury or death to personnel.

**WARNING OR CAUTION:** If not correctly followed there is some possibility of serious injury or death to personnel.



THE '**SAFETY ALERT**' SYMBOL IS USED TO CALL ATTENTION TO POTENTIAL HAZARDS THAT MAY LEAD TO SERIOUS INJURY OR DEATH, IF IGNORED.

**IMPORTANT AND INSTRUCTIONS:** Denotes procedures essential to safe operation and prevention of damage to or destruction of the machine.

**NOTICE:** Indicates general safety rules and/or procedures relating to the machine.

**It is the owner's/user's responsibility to know and comply with all applicable rules, regulations, laws, codes and any other requirements applicable to the safe use of this equipment.**

## **1.2 SCOPE**

These operating instructions contain all the necessary information required to allow the safe operation of any Niftylift Height Rider 15N (SP45N in the USA), powered by electric (DC), diesel (D), or a combination of these.

For further technical information, circuit diagrams and specific instructions for all maintenance which may need to be carried out by specialist trained personnel, see the associated Workshop and Parts manual for your model of Niftylift Height Rider.

## **1.3 INTRODUCING THE HEIGHT RIDER SELF-PROPELLED (SP) SERIES**

Please note at the time of going to press all information, illustrations, details and descriptions contained herein are valid. Niftylift reserves the right to change, modify or improve its products without any obligations to install them on previously manufactured machines.

If, after reading this manual you require further information, please do not hesitate to contact us.

**Niftylift Ltd, Fingle Drive, Stonebridge, Milton Keynes MK13 0ER, Great Britain**

**Tel: +44 (0) 1908 223456 Fax: +44 (0) 1908 312733**

**Niftylift Inc, 573 Summerdale Ave, Glen Ellyn, IL 60137-5726 USA**

**Tel: +01 630 858 2575 Fax: +01 630 858 0520**

Driven from the platform, the Niftylift Height Rider 15N (HR15N) is an extremely versatile articulated boom platform of unique and simple design. It is capable of placing two men and their tools up to a height of 15.60m (51ft) or an outreach of 9.60m (31ft 6in).

The booms are mounted via a 360° powered swing mechanism onto a compact narrow base with a tight turning circle that ensures excellent manoeuvrability and maximum efficiency.

High traction tyres and powerful hydraulic wheel motors give unsurpassed performance with the option of fast drive speed when the booms are in the stowed position. Automatic braking and audible alarms activated by a five-degree tilt sensor help to prevent the operator from working on unsafe terrain whilst elevated.

A simple, all-hydraulic proportional control system gives smooth, reliable movement of the platform and maximum reliability in the harshest environments.

*Models include the following:*

E: - DC ELECTRIC                      DE: - BI-ENERGY (DIESEL & BATTERY)  
D: - DIESEL

**Operating & Safety Instructions****1.4 GENERAL SPECIFICATION**

<b>FEATURE</b>	<b>HR15N (SP45N)</b>
MAXIMUM HEIGHT - WORKING	15.60m 51ft
MAXIMUM HEIGHT - PLATFORM	13.60m 44ft 7in
MAXIMUM OUTREACH	9.60m 31ft 6in
MAXIMUM HEIGHT – STOWED	1.95m 6ft 6in
MAXIMUM WIDTH	1.50m 4ft 11in
MAXIMUM LENGTH – STOWED	5.94m 19ft 6in
PLATFORM CAPACITY - Europe	225kg (500lbs)
WHEELBASE	1.95m 6ft 6in
TURNING RADIUS – OUTSIDE	3.31m 10ft 10in
TURRET ROTATION	355°
TURRET TAIL SWING	Zero
TRAVEL SPEED	0-2.5mph 0-4kph
PLATFORM SIZE	1.50m x 0.70m 5ft x 2ft 5in
CONTROLS	Proportional electric over hydraulic
HYDRAULIC PRESSURE	200bar
TYRES	Solid, non marking optional
GRADE-ABILITY	25%
MINIMUM VEHICLE WEIGHT	6,400kg 14,097lb
MAXIMUM GROUND PRESSURE	0.152kn/cm <sup>2</sup> 31,735lb/ft <sup>2</sup>
POWER SOURCE	E (Electric) models - 8 x 6v 350 AH batteries D (Diesel) models - Kubota 722 (2X4 & N) OR Kubota 1505 (4x4) DE (Diesel & Battery) – Diesel Bi-Energy

**1.5 IDENTIFICATION (UK PLATE)**

			
NIFTYLIFT LTD. FINGLE DRIVE, STONEBRIDGE MILTON KEYNES MK13 0ER ENGLAND TEL 01908 223456 : FAX 01908 312733 e-mail : info@niftylift.com			
SERIAL No			
TYPE			
YEAR OF MANUFACTURE			
WEIGHT			kg
RATED LOAD	PERSONS	+	kg
MAXIMUM SAFE WORKING LOAD			kg
MAXIMUM PULL			N
MAXIMUM WIND SPEED			m/s
MAX. ALLOWABLE INCLINATION			Deg.
MAXIMUM HYDRAULIC PRESSURE			bar
MAXIMUM VOLTAGE			V
AMPS			A
ELEC. CCT D	ISSUE		
HYD. CCT D	ISSUE		
			P10805

**This manufacturer's plate is attached to Boom 1 on each machine at the time of manufacture on every Niftylift. Please ensure all sections have been stamped and are legible.**

**1.5 a IDENTIFICATION (USA PLATE)**

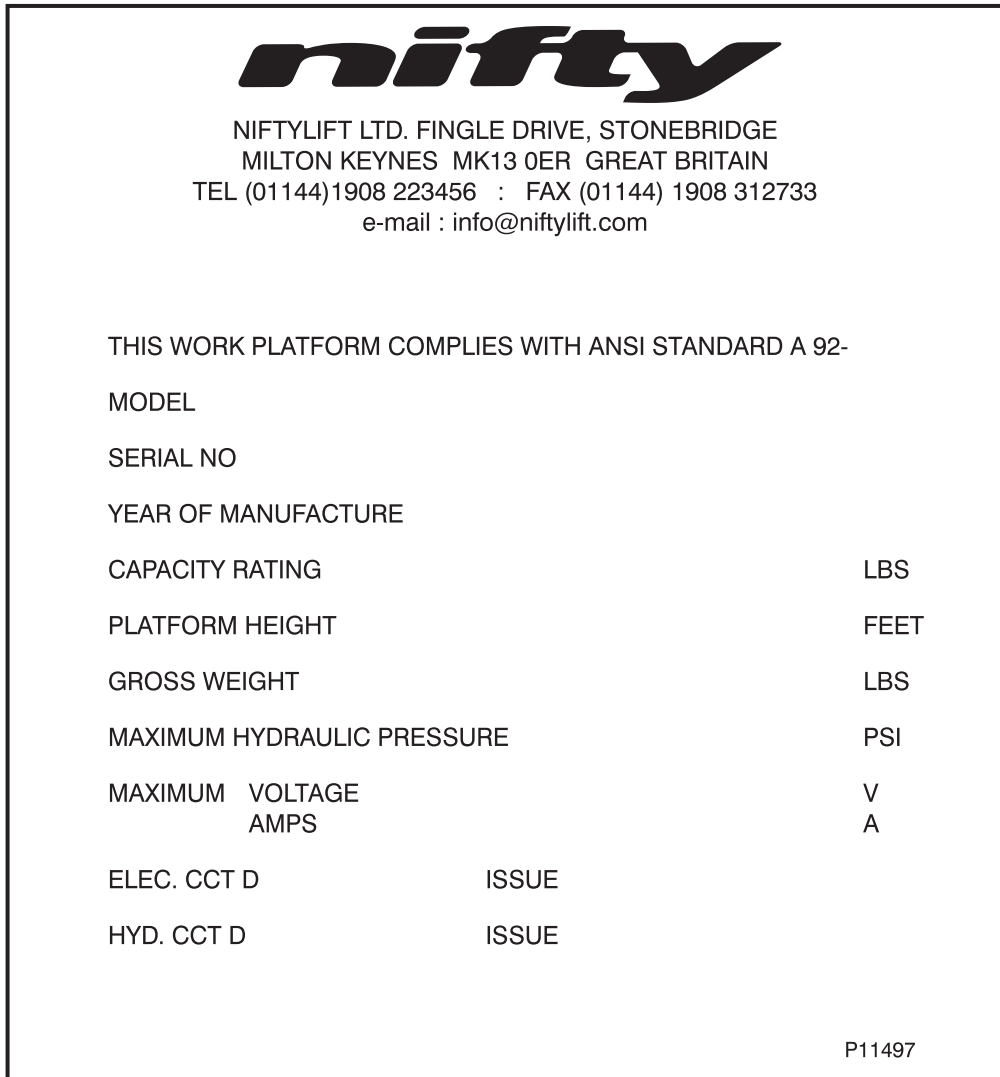

**This manufacturer's plate is attached to Boom 1 on each machine at the time of manufacture on every Niftylift. Please ensure all sections have been stamped and are legible.**

## **2. Safety**

### **2.1 MANDATORY PRECAUTIONS**

When operating your Niftylift, your safety is of utmost concern. In order to fully appreciate all aspects of the machines operation it should be ensured that each operator has **READ** and fully **UNDERSTOOD** the relevant manual covering machine use, maintenance and servicing. If any doubts exist concerning any points covered in your manual, contact your local dealer or Niftylift Ltd.

Before using any Niftylift, thoroughly inspect the machine for damage or deformation to all major components. Likewise, check the control systems for hydraulic leaks, damaged hoses, cable faults or loose covers to electrical components. At no time should damaged or faulty equipment be used - Correct all defects before putting the platform to work. If in doubt, contact your local dealer or Niftylift Ltd (see front cover for address).



**THE MANUFACTURER HAS NO DIRECT CONTROL OVER THE MACHINE APPLICATION AND USE. THEREFORE CONFORMANCE WITH GOOD SAFETY PRACTICES IS THE RESPONSIBILITY OF THE USER AND HIS OPERATING PERSONNEL. FAILURE TO UNDERSTAND AND FOLLOW ALL SAFETY RULES COULD RESULT IN SERIOUS INJURY OR DEATH.**

- 2.1.1** Only trained persons will be permitted to operate the Niftylift.
- 2.1.2** Always operate the Niftylift in full accordance with the manufacturers Operating & Safety Instructions for that model.
- 2.1.3** Before use each day and at the beginning of each shift the Niftylift shall be given a visual inspection and functional test including, but not limited to, operating and emergency controls, safety devices, personal protective clothing, including fall protection, air, hydraulic and fuel system leaks, cables and wiring harness, loose or missing parts, tyres and wheels, placards, warnings, control markings and Operating and Safety Manuals, guards and guard rail systems and all other items specified by the manufacturer.
- 2.1.4** Any problems or malfunctions that affect the safety of operations shall be repaired prior to the use of the Niftylift.
- 2.1.5** Always ensure that all warning labels, instructions, placards, control markings and Safety Manuals are intact and clearly legible. If replacements are required contact your local dealer or Niftylift. Always observe and obey safety and operating instructions on such labels.
- 2.1.6** Do not alter, modify or disable in any way the controls, safety devices, interlocks or any other part of the machine.
- 2.1.7** Before the Niftylift is used and during use the user shall check the area in which it is to be used for possible hazards such as, but not limited to, uneven ground drop-offs, holes, bumps, obstructions, debris, floor and overhead obstructions, high voltage conductors, wind and weather, unauthorised persons and any other possibly hazardous conditions.



**Operating & Safety Instructions**

- 2.1.8** Never exceed the maximum platform capacity, as indicated on the decals and machine serial plate.
- 2.1.9** Only operate the Niftylift on a firm, level surface.
- 2.1.10** Never position any part of the Niftylift within 10ft (3m) of any electrical power line, conductor or similar above 450 volts



**THIS MACHINE IS NOT INSULATED.**

If in doubt, contact the appropriate authorities

- 2.1.11** On entering the platform ensure that the drop down entry bar is closed afterwards.
- 2.1.12** Use of an approved safety belt and lanyard, hard hat and appropriate safety clothing is mandatory. Fasten harness to designated harness securing points within the platform and do not remove until leaving the platform whilst in the stowed position.

**2.1.13**



Always remain standing within the platform. Do not attempt to increase your height or reach by standing and/or climbing on the platform guard rails or any other object. **KEEP YOUR FEET ON THE PLATFORM FLOOR.** Do not sit, stand or climb on the guard rail, mid rail or boom linkage. Use of planks, ladders or any other devices on the Niftylift for achieving additional height or reach shall be prohibited.

- 2.1.14** Do not use the platform levelling system to artificially increase the outreach of the platform. Never use boards or ladders in the platform to achieve the same result.
- 2.1.15** Do not use the platform to lift overhanging or bulky items that may exceed the maximum capacity or carry objects that may increase the wind loading on the platform. (e.g. Notice boards etc.)
- 2.1.16** The Niftylift shall not be operated from a position on trucks, trailers, railway cars, floating vessels, scaffolds or similar equipment unless the application is approved in writing by Niftylift Ltd in Great Britain.
- 2.1.17** Always check that the area below and around the platform is clear of personnel and obstructions before lowering or slewing. Care should be taken when slewing out into areas where there may be passing traffic. Use barriers to control traffic flow or prevent access to the machine.
- 2.1.18** Stunt driving and horseplay, on or around the Niftylift, shall not be permitted.
- 2.1.19** When other moving equipment and vehicles are present, special precautions shall be taken to comply with local ordinances or safety standards established for the work place. Warnings such as, but not limited to, flags, roped off areas, flashing lights and barricades shall be used.
- 2.1.20** Before and during driving while the platform is elevated the operator shall maintain a clear view of the path of travel, maintain a safe distance from obstacles, debris, drop offs, holes, depressions, ramps and other hazards to ensure safe elevated travel. Maintain a safe distance from overhead obstacles.

---

**Operating & Safety Instructions**

- 2.1.21** Under all travel conditions the operator shall limit travel speed according to conditions of ground surface, congestion, visibility, slope, location of personnel and other factors causing hazards of collision or injury to personnel.
- 2.1.22** The aerial platform shall not be driven on grades, side slopes or ramps exceeding those for which the aerial platform is rated by the manufacturer.
- 2.1.23** It shall be the responsibility of the user to determine the hazard classification of any particular atmosphere or location. Aerial platforms operated in hazardous locations shall be approved and suitable for the duty. (See ANSI/NFPA 505-1987 where applicable).
- 2.1.24** The operator shall immediately report to his supervisor any potentially hazardous location(s) (environment) which become evident during operation.
- 2.1.25** If an operator encounters any suspected malfunction of the Niftylift or any hazard or potentially unsafe condition relating to capacity, intended use or safe operation, he shall cease operation of the Niftylift and request further information as to safe operation from his management, or owner, dealer or manufacturer before further operation of the Niftylift.
- 2.1.26** The operator shall immediately report to his superior any problems or malfunctions of the Niftylift, which becomes evident during operation. Any problems or malfunctions that affect the safety of operation shall be repaired prior to continued use.
- 2.1.27** The boom and platform of the Niftylift shall not be used to jack the wheels off the ground.
- 2.1.28** The Niftylift shall not be used as a crane.
- 2.1.29** The Niftylift shall not be positioned against another object to steady the platform.
- 2.1.30** Care should be taken to prevent rope, electric cords and hoses from becoming entangled in the aerial platform.
- 2.1.31** Batteries shall be recharged in a well-ventilated area free of flame, sparks or other hazards, which may cause explosion. Highly explosive hydrogen gas is produced during the charging process.
- 2.1.32** When checking electrolyte levels great care should be taken to protect eyes, skin and clothing. Battery acid is highly corrosive and protective glasses and clothing is recommended.
- 2.1.33** If the platform or elevating assembly becomes caught, snagged or otherwise prevented from normal motion by adjacent structure or other obstacles, such that control reversal does not free the platform, all personnel shall be removed from the platform safely before attempts are made to free the platform using ground controls.

**Operating & Safety Instructions**

**2.1.34**



When the machine is not in use always stow the booms correctly. **NEVER LEAVE THE KEYS IN THE MACHINE**, if it is to be left for any period of time. Use wheel chocks if leaving on an incline.

**2.1.35**

The engine must be shut down while fuel tanks are being filled. Fuelling must be done in a well-ventilated area free of flame, sparks or any other hazard that may cause fire or explosion. **PETROL (GASOLINE), LIQUID PROPANE AND DIESEL FUELS ARE FLAMMABLE.**

**2.1.36**



**NEVER START THE NIFTYLIFT IF YOU SMELL PETROL (GASOLINE), LIQUID PROPANE OR DIESEL FUEL. THESE FUELS ARE HIGHLY FLAMMABLE**

**2.1.37**

The operator shall implement means provided to protect against use by unauthorised persons.

**2.1.38**

Never remove anything that may affect the stability of the machine such as, but not limited to, batteries, covers, engines, tyres or ballast.

## **2.2 ENVIRONMENTAL LIMITATIONS**

Unless specifically configured otherwise, the machine will have a short operational time in extreme temperatures such as freezers and cold storage, due to reduced battery performance. For electrical cables and components, the temperature must be within the range -5°C to 60°C.

The machine is limited in high temperatures because of the cooling requirement for engines and hydraulic oil. Coolant temperatures must be within the range -37°C to 110°C (at 50% mixture of water to anti-freeze). Oil temperature not to exceed -23°C to 93°C.

**The recommended operational range for these machines is - 5°C to +40°C. Please contact Niftylift Ltd for special considerations if the machine is required to operate outside these temperatures.**

Extended operation in dusty environments is not recommended, frequent cleaning will be necessary. All dust, dirt, salt encrustation, excess oil or grease should be removed. Deposits of paint or bitumen, particularly on legends or labels should be removed.

All standard Niftylift machines are rated for a wind speed of 12.5 m/s, which equates to 45kph / 28mph or force 6 on the Beaufort scale. No attempt should be made to operate a Niftylift in wind strengths above this limit and if the operator has any doubts over the wind speed he / she should cease operation immediately until it can be established that the wind speed has fallen to a safe level.

## **2.3 NOISE AND VIBRATION**

The airborne noise emission on the Height Rider range of machines does not exceed 79dB(A), measured at a perpendicular distance of 4m, under equivalent continuous A-weighted sound pressure test conditions. This was based on a Diesel powered machine, working on high throttle, and under load. All other models will exhibit significantly lower emissions than this figure, dependant on power option. In normal operation the Vibration level to which the operator is subjected will not exceed a weighted root mean square acceleration value of 2.5 m/s<sup>2</sup>.

## **3. Preparation and Inspection**

### **3.1 UNPACKING**

Since the manufacturer has no direct control over the shipping or carriage of any Niftylift it is the responsibility of the dealer and/or owner and/or lessee to ensure the Niftylift has not been damaged in transit and a Pre-operational Report has been carried out by a qualified engineer before the aerial platform is put into service.

- A) Remove all ropes, straps and or chains used to secure the aerial platform during transit.
- B) Ensure any ramp, loading dock or forklift used is capable of supporting or lifting the aerial platform.
- C) If the aerial platform is to be driven off, please ensure that the operator has read and fully understood this entire manual. Refer to the appropriate section for precise operating instructions.

**\*\*\*Carry out the Pre-operational Report before placing machine in service.**

### **3.2 PREPARATION FOR USE**

Whilst every effort has been made at the Niftylift factory to ensure your machine arrives in a safe and operable condition it is necessary to carry out a systematic inspection prior to putting the aerial platform into service.



**THIS IS NOT A REQUEST IT IS MANDATORY**

To assist the user in this task you will find enclosed a Pre-operational Report, which must be filled out upon delivery/receipt of the machine.

Before the user carries out the Pre-operational Report he must have read and fully understood all the contents of the Operating, Safety and Maintenance Manual.



**WARNING - DO NOT OPERATE A POTENTIALLY DEFECTIVE OR MALFUNCTIONING MACHINE. CORRECT AND REPAIR ANY DEFECTS BEFORE OPERATING YOUR NIFTYLIFT.**

### **3.3 PRE-OPERATIONAL SAFETY CHECK SCHEDULES**

Before use each day and at the beginning of each shift the aerial platform shall be given a visual inspection and functional test including, but not limited to, the following:

#### **3.3.1 DAILY SAFETY CHECKS**

- 1) Check that all labels (decals) are in place and legible.
- 2) Visually inspect the machine for damaged or loose components.
- 3) Check that batteries are charged (i.e. Charger has a solid green light and a pulsing red light).
- 4) Check the fuel level (if applicable).
- 5) Check that canopies/covers and guards are in place and secure.
- 6) Check that the boom rest switch is operable (if applicable).
- 7) Check that control levers are secure and operate freely.
- 8) Check that operating buttons and emergency stop buttons function properly.
- 9) Check the operation of the emergency hand pump.
- 10) Visually inspect all hydraulic hoses and fittings for damage or leaks.
- 11) Check that the platform pivot pins and their tag bolts are secure.
- 12) Check that the tilt alarm is functioning properly (On a slope of 5° or more the alarm should sound and drive should be disabled)

#### **3.3.2 WEEKLY SAFETY CHECKS**

- 1) Inspect tyres and wheels for damage and wear.
- 2) Check battery fluid levels and specific gravity (after charging) and general condition.
- 3) Check hydraulic oil level (ISO Grade 22).
- 4) Inspect the engine air filter and clean or replace if necessary.
- 5) Inspect hose track for damage or missing parts.

#### **3.3.3 MONTHLY SAFETY CHECKS**

- 1) Check the engine oil level (if applicable).
- 2) Check the wheel nuts (torque 110ft lbs / 150Nm).
- 3) Check that the slew worm is secured and correctly in mesh. Clean and re-grease.
- 4) Check the track rod linkage.

#### **3.3.4 ANNUAL SAFETY CHECKS**

- 1) Check that all pivot pins and their tag bolts are secure.
- 2) Inspect for any cracks or badly rusted areas on booms and chassis.
- 3) Change the hydraulic oil filters.
- 4) Check the bushes in the front wheel hubs for wear.
- 5) Check that slew ring bolts are secure (torque 220ft lbs. 300Nm).

**3.4 PLACARD, DECALS & INSTALLATION (UK SPEC)**

<b>ITEM</b>	<b>DESCRIPTION</b>	<b>NUMBER</b>	<b>QTY</b>
1	"Niftylift.com"	P14597	1
2	Harness Point	P14883	2
3	Head Protection	P14921	1
4	General Warning	P15227	2
5	"If E-stop disabled"	P14864	2
6	Hydraulic Oil	P14415	1
7	Safe Working Load 225kg	P14781	1
9	"If tilt alarm sounds"	P14868	2
11	General Crush	P14782	4
12	Travel Direction	P14784	1
13	Blank serial plate	P15383	1
14	Gearbox Disengage	P14802	3
15	Battery Isolator	P16231	1
16	No Step	P14785	5
18	"Nifty HR15N" – Grey	P14606	2
19	Trip – Push to reset	P10875	1
20	"If footswitch disabled"	P14884	2
21	"Height Rider 15N" – Grey	P14607	2
23	Component Stability	P17203	1
24	"Raise platform"	P14832	1
25	Platform Controls	P12517	
27	Daily Check List	P14908	1
28	Point Load – 38.1kg	P14972	4
29	Battery Charger Warning	P14904	1
31	Diesel Warning	P14414	1
32	Fuels are flammable	P14900	1
34	General Notice HR's	P14417	1
36	Base Controls	P12687	1
39	Oil Level Indicator	P14676	1
40	Union Jack	P10780	1
41	Operating Instructions	P14892	1
42	Emergency Hand Pump	P14811	1
46	Soft Stop Warning	P17460	1

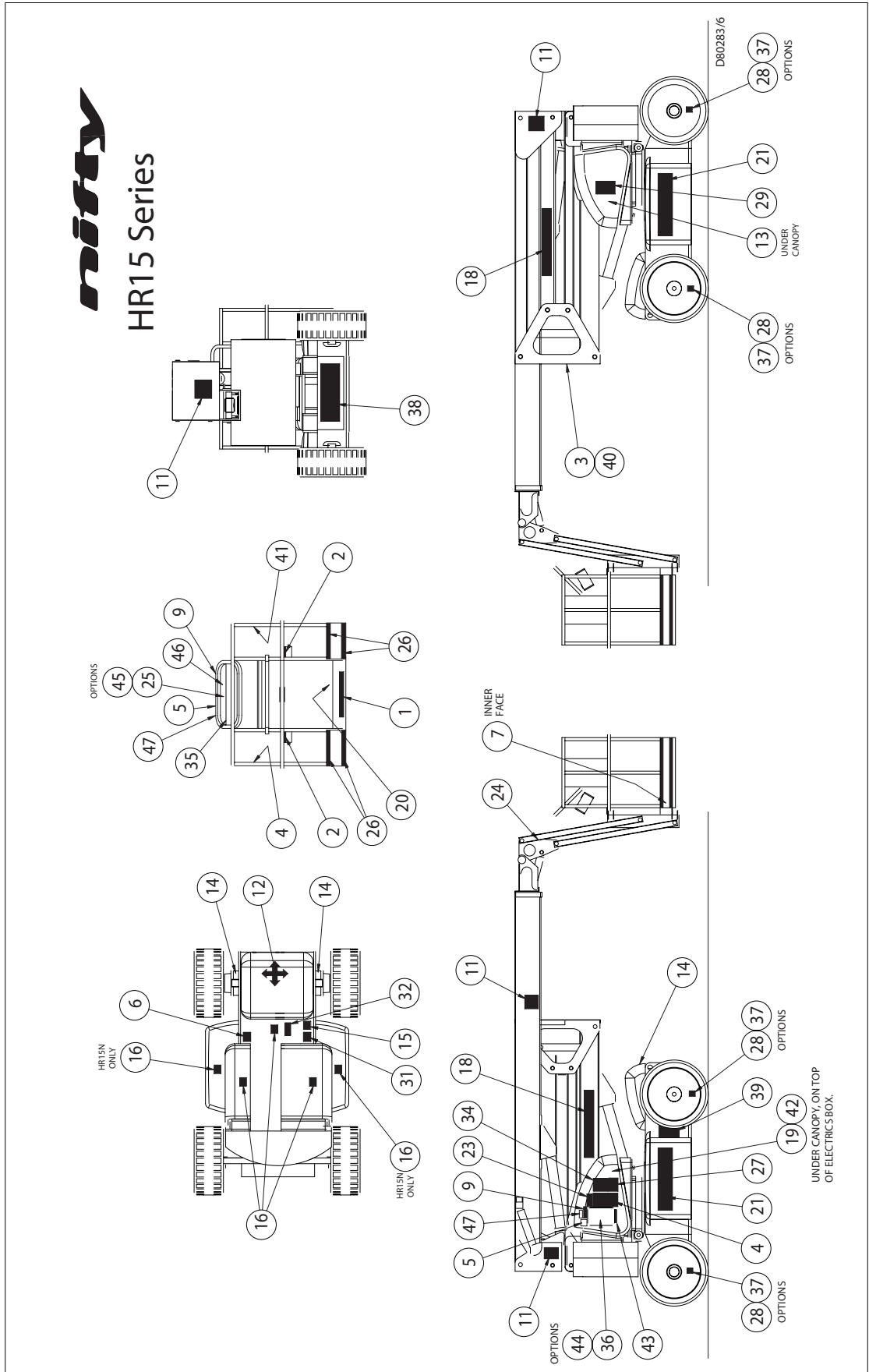



**3.5 TORQUE REQUIREMENTS**

SCREW QUALITY/SIZE	Tightening torque in ft lbs (Nm)			
	8.8		10.9	
M 6	7.0	(10)	10	(14)
M 8	19	(25)	26	(35)
M 10	36	(49)	51	(69)
M 12	63	(86)	89	(120)
M 14	99	(135)	140	(190)
M 16	155	(210)	218	(295)
M 18	214	(290)	300	(405)
WHEEL NUTS	110ft lbs		150Nm	
WHEEL MOTOR NUTS	99ft lbs		135Nm	
SLEW RING BOLTS	220ft lbs		300Nm	

## 4. Operation

### 4.1 CONTROL CIRCUIT COMPONENTS

- 4.1.1 MAIN CONTROL BOARD:** - Situated under the right-hand superstructure canopy, the principle electrical box houses the Main Control Box. This PCB (Printed Circuit Board) incorporates all of the relays to control the machines operation. The control board is common to all models and contains functions, which might not be utilized on your particular machine. Thermal trips are integral to the box, the functions of which are described in a later section of this manual. (See 4.1.14) The purpose of the Main Control Board is to interpret the signals received from the two control stations and energise the machine movements accordingly.
- 4.1.2 BASE CONTROL BOARD:** - Adjacent to the Main Control Board and attached to the same bracket is the Ground Control Station. Situated behind the Ground Control Pushbuttons will be found the Base Control Board. This PCB incorporates all of the relays to control the ground functions of the machine. The purpose of the Ground Control Board is to generate all of the signals required to operate the machine, which are then fed to the Main Control Board.
- 4.1.3 PLATFORM CONTROL BOARD:** - Situated in the platform is the Platform Control Station. Behind the platform control pushbuttons will be found the Platform Control Board. This PCB incorporates all of the relays to control the platform functions of the machine. The purpose of the platform control board is to generate all of the signals required to operate the machine, which are then fed through to the Main Control Board.
- 4.1.4 TILT ALARM:** - Fitted to the superstructure behind the base controls cover, the tilt alarm is a solid-state sensor, which monitors the inclination of the machine. It directly controls the BRV (Brake Release Valve) and when the platform is in use, i.e. Booms are raised, if the inclination exceeds the pre-set limit, it will disable the drive to the machine and sound the alarm. In order to recover the machine, the platform operation is unaffected, allowing the operator to restore drive when the machine is stowed. It is then possible to drive back onto level ground, fully restoring machine operation.
- 4.1.5 SOUNDER:** - Situated on the back of the base control box is a small electric sounder, which is used to provide an intermittent alarm whenever the machine is in operation. Pushing a green "power control" button or depressing the foot switch in the platform (if fitted) will energise this sounder. This serves to warn personnel of the operation of the machine.
- 4.1.6 KLAXON:** - Also mounted on the top of the control board box is a klaxon, which performs several functions: Firstly, it can be used as a manual alert, by pushing the "Horn" button at the platform control position. Secondly, it is this device, which sounds continuously if the tilt alarm sensor detects excessive inclination, with the booms raised. Thirdly this will sound when the fuel warning light comes on. Lastly, it is linked into the battery management system, such that when low battery state is reached the "pulsing" of the DC motors is mimicked by the klaxon, re-enforcing the message to the operator to recharge the batteries.

---

**Operating & Safety Instructions**

**4.1.7 DRIVE CONTROL VALVE (DCV):-** The motion control valve comprises several individual components all directly involved in the hydraulic supply to the wheel drive motors. Principal amongst these are the drive control valves, which electrically change the drive motor hydraulics supply from series flow to parallel, or vice versa. This control function is only available when the booms are lowered, and allows the operator to select "Hi" or "Lo" drive. "Hi" drive gives fast speed of travel, but low gradeability, "Lo" drive gives best gradeability, but slow speed. "Lo" drive is used for climbing inclines and delicate positioning of the machine.

**4.1.8 BRAKE RELEASE VALVE (BRV):-** The motion control valve also incorporates a solenoid operated dump valve, which controls the brake function on the machine. This valve must be energised to allow the machine to move. If no voltage is present, the wheel motors will not be able to develop drive torque, whilst at the same time, the parking brakes will remain engaged. Only when a green "Power Control" push-button is being used (or the Platform Foot-switch is depressed) will the BRV operate. If the tilt alarm sensor detects an excessive inclination whilst the booms are raised it is the BRV which is de-energised to isolate the machine. (At the same time the klaxon tone changes to a continuous tone to indicate this condition)

**4.1.9 BOOM SWITCH: -** Mounted on the links knuckle and tele-boom, and operated by any of the booms raising and/or the telescopic boom going out, these switches control both the operation of the tilt alarm sensor, and the speed control function. With the booms in the stowed position, the tilt alarm sensor is by-passed, allowing the machine to negotiate slopes in excess of the permissible working angle, without isolating the drive function. At the same time, "Hi" drive is possible, as is fast throttle on those machines so equipped. When the booms are raised, the tilt alarm sensor becomes activated, only slow speed operation is possible and only "Lo" drive is permitted. These control functions are of primary importance to safety of the machine and operator. Under no circumstances should this control function be isolated or by-passed. Note! On later machines the boom switch is located adjacent to the Knuckle, and works from a cam attached to Boom 3. This permits the operator to slightly raise the Booms whilst still permitting high-speed drive. All other functions remain the same.

**4.1.10 BATTERY MANAGEMENT: -** Battery condition is permanently monitored by the control circuit, such that when available power has decreased to 80% of full charge, the battery status circuit begins to "chop" the power to the hydraulic power packs. This function causes the drive system to alternately stop and start, signalling to the operator that re-charging is necessary. At the same time the Klaxon will begin to sound intermittently re-enforcing the charge warning. At this point, sufficient power remains to drive to the nearest power point. Should the operator ignore the on-set of the discharge warning, the "chopping" will continue until the machine is rendered inoperative. Immediate charging will then be required.

Under no circumstances should a machine be left fully discharged or severe battery damage can occur in a relatively short time.

- 4.1.11 BATTERY ISOLATORS:** - The battery-disconnect handles are located beneath the central canopy and allow the machine control and power circuits to be isolated from the batteries. In order to isolate the batteries it is necessary to pull **both** release handles. The left side release handle also incorporates a control circuit connector. Pulling this handle also disconnects the supply to the PCB control box. Under normal operation, the machine key switch should be used to isolate the machine, with the battery isolator handles only being required for emergencies, in the event of a short circuit, or during routine maintenance.
- 4.1.12 DUTY SELECTOR:** - On multiple power option machines, one of the functions on the platform control station will be a duty selector. This key switch allows the selection of either power option, i.e. from Diesel to Battery or Petrol to battery, or vice-versa. On other machines this same key switch serves as an "On-Off" control.
- 4.1.13 DIESEL ENGINE:** - Generally a Kubota 722 engine, driving a twin bodied pump with direct mounted pump dump valves (one per section), and integral relief valve on the rear pump. The arrangement allows two speed operation, fast throttle and automatic relief for ramp climbing.
- 4.1.14 FUSES & TRIP SWITCHES:** - There are four actual fuses and three trip switches. 1) 120A fuse near the diesel engine battery (this is for the starter motor and alternator). 2) 20A fuse also near the diesel battery on the positive battery lead (this is for the solenoid, glow-plugs and throttle). 3) 225/325A fuse for the electric hydraulic pump motor (this fuse is found by the battery isolator) 4) 10A fuse for the 48v to 12v converter which supplies the control system (also found by the battery isolator). 5) 10A circuit breaker for the drive/boom selector solenoid, tank dump, steer and DCV (located in the main control box). 6) 10A circuit breaker which controls the rest of the solenoids – boom functions drive and brake release (located in main control box). 7) 1A circuit breaker is for the electronic controls (located in main control box).

**4.2 GROUND CONTROL OPERATION**

**4.2.1 GROUND CONTROL FUNCTIONS**

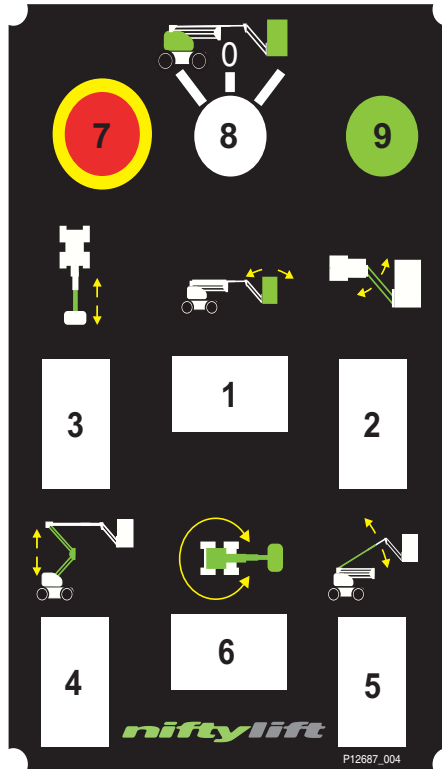

**(Ground Control Station)**

<b>1</b> Operates Platform Levelling	Left for <b>Forward**</b>	Right for <b>Backward**</b>
<b>2</b> Operates the Flyboom	Up for <b>Up</b>	Down for <b>Down</b>
<b>3</b> Operates Telescoping	Up for <b>In</b>	Down for <b>Out</b>
<b>4</b> Operates the Link Booms	Up for <b>Up</b>	Down for <b>Down</b>
<b>5</b> Operates the Upper Boom	Up for <b>Up</b>	Down for <b>Down</b>
<b>6</b> Operates Swing	Left for <b>Left</b>	Right for <b>Right</b>
<b>7</b> Emergency Stop	Push to <b>Stop Operation</b>	Twist to <b>Enable Operation</b>
<b>8</b> Base Key Switch	Anti-clockwise for <b>Base</b>	Clockwise for <b>Platform</b>
<b>9</b> Green Power Button	Push and hold for <b>Power</b>	Release to <b>Cease</b> operation

**\*\*** Platform levelling only active when booms are down

**4.2.2 OPERATION**

**ALWAYS ALLOW THE ENGINE TO WARM UP BEFORE OPERATING.  
ALL MODELS**



- 1) Ensure all red emergency stops are out.
- 2) Turn key switch at ground control station to **Ground** (fully anti-clockwise).
- 3) For **Battery** powered operation, go to step 8).
- 4) For **Diesel** powered operation, go to step 5).

**DIESEL ENGINE OR BI-ENERGY MODELS**

- 5) Turn the duty selector in the platform to **Engine** (fully clockwise). For a cold engine start go to step 6), for a warm engine start go to step 7).
- 6) **COLD ENGINE**: - turn the main engine ignition key switch (located beneath the central cover) to the **Glow** position (anti-clockwise). This engages the glow plug pre-heat system. Hold for 3-5 seconds then turn the key to the **Start** position (fully clockwise) and the engine will fire.
- 7) **WARM ENGINE**: - turn the main engine ignition switch (located beneath the central cover) to the **Start** position (clockwise) and the engine will fire.

Note – Unless the diesel engine is running, the HR15N will automatically default to the primary power source (usually battery)

**ALL MODELS**

- 8) Push and hold green power button on the base control box.
- 9) Select a function and operate the appropriate rocker switches in full accordance with manufacturers operating and safety manual.
- 10) To return control to the platform turn base control key-switch to the **Platform** position (fully clockwise).
- 11) When not in use return machine to stowed position, turn the base control key-switch to centre **Off** position, remove key and chock wheels.

Note – Unless the diesel engine is running, the HR15N will automatically default to the primary power source (usually battery)

**EMERGENCY PROCEDURES**

- 1) Push in red emergency stop to shut down all functions.
- 2) Operate the emergency descent valves located under the base control panel on the superstructure. These must be pulled in or out depending on the direction of travel required. Refer to the decal inside the panel for the relevant controls.
- 3) With the relevant descent valve pushed in or pulled out operate the emergency hand pump, located inside the same panel.
- 4) If hand pump locks up, check that the **Booms** tap on the DCV is open. (See section 5.3)

**4.3 PLATFORM CONTROL OPERATION**

**4.3.1 PLATFORM CONTROL FUNCTIONS**

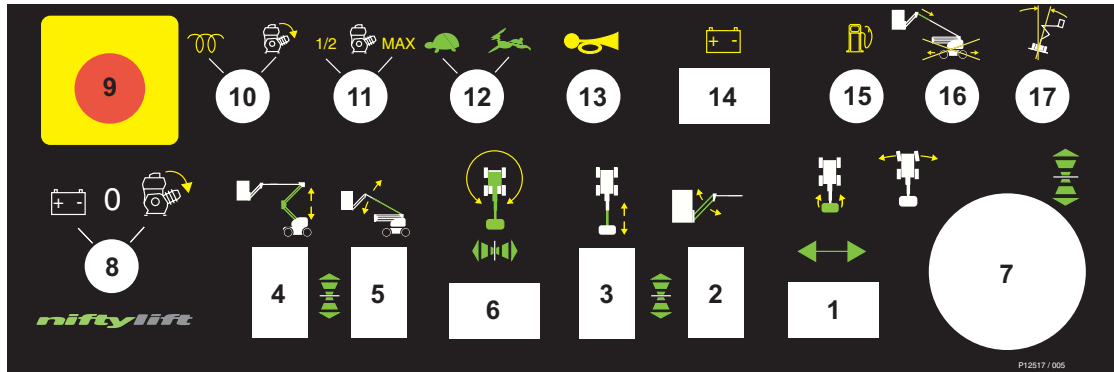

**(Platform Control Station)**

<b>1</b> Operates Platform Rotation	Left for <b>Clockwise</b>	Right for <b>Anti-Clockwise</b>
<b>2</b> Operates the Flyboom	Up for <b>Up</b>	Down for <b>Down</b>
<b>3</b> Operates Telescoping	Up for <b>Tele-In</b>	Down for <b>Tele-Out</b>
<b>4</b> Operates the Link Booms	Up for <b>Up</b>	Down for <b>Down</b>
<b>5</b> Operates the Upper Boom	Up for <b>Up</b>	Down for <b>Down</b>
<b>6</b> Operates Swing	Left for <b>Left</b>	Right for <b>Right</b>
<b>7</b> Drive Joystick	Forward for <b>Forward</b>	Back for <b>Reverse</b>
<b>8</b> Duty Selector	Anti-clockwise for <b>Battery</b>	Clockwise for <b>Engine</b>
<b>9</b> Emergency Stop	Push to <b>Stop Operation</b>	Twist to <b>Enable Operation</b>
<b>10</b> Engine Start	Anti-clockwise for <b>Glow</b>	Clockwise to <b>Start</b>
<b>11</b> Engine Revs	Anti-clockwise for <b>½ Revs</b>	Clockwise for <b>Max Revs</b>
<b>12</b> Drive Speed	Anti-clockwise for <b>Slow</b>	Clockwise for <b>Fast</b>
<b>13</b> Horn	Press and hold to <b>Sound</b>	
<b>14</b> Battery level Indicator		
<b>15</b> Fuel level Indicator		
<b>16</b> Outreach limit Indicator		
<b>17</b> Tilt Alarm Indicator		

**Operating & Safety Instructions**

**4.3.2 OPERATION**



**NEVER START THE NIFTYLIFT IF YOU SMELL PETROL (GASOLINE), LIQUID PROPANE OR DIESEL. THESE FUELS ARE FLAMMABLE.**

**BEFORE OPERATING THE NIFTYLIFT ENSURE THAT EACH OPERATOR HAS READ AND FULLY UNDERSTOOD THE OPERATING MANUAL. FAILURE TO DO SO MAY RESULT IN DEATH OR SERIOUS INJURY.**

**ALL MODELS**

- 1) Ensure all red emergency stops are out.
- 2) Turn key switch at ground control station to **Platform** (fully clockwise).
- 3) For **Battery** powered operation, go to step 8).
- 4) For **Diesel** powered operation, go to step 5).

**DIESEL ENGINE OR BI ENERGY MODELS**

- 5) Turn the duty selector in the platform to **Engine** (fully clockwise). For a cold engine start go to step 6), for a warm engine start go to step 7).
- 6) **COLD ENGINE:** - turn the engine ignition switch (on the platform control box) to the **Glow** position (anti-clockwise). This engages the glow plug pre-heat system. Hold for 3-5 seconds then turn the switch to the **Start** position (fully clockwise) and the engine will fire.
- 7) **WARM ENGINE:** - turn the main engine ignition switch (on the platform control box) to the **Start** position (clockwise) and the engine will fire.

Note – Unless the diesel engine is running, the HR15N will automatically default to the primary power source (usually battery)

**ALL MODELS**

- 8) Depress the footswitch or push and hold green power button on the platform control box.
- 9) Select a function and operate the appropriate proportional paddles (levers) in full accordance with manufacturers operating and safety manual.
- 10) To return control to the base turn base control key-switch to the **Base** position (fully anti-clockwise).
- 11) When not in use return booms to the stowed position. Turn key switch on the ground control station to the centre **Off** position, remove key and chock wheels.

Note – Unless the diesel engine is running, the HR15N will automatically default to the primary power source (usually battery)



**ALWAYS ENSURE THE AERIAL PLATFORM IS ON A FIRM LEVEL SURFACE AND THE AREA IS FREE OF ANY OVERHEAD OBSTRUCTIONS.**

**ENGAGING THE RED EMERGENCY STOP BUTTON WILL SHUT DOWN THE ENGINE, AND THE ELECTRIC CIRCUIT PREVENTING OPERATION OF ANY FUNCTION.**



**4.4 DRIVING CONTROLS**



**DO NOT OPERATE THE NIFTYLIFT WHILST ELEVATED UNLESS ON A FIRM, LEVEL SURFACE FREE FROM ANY POSSIBLE OBSTRUCTIONS OR HAZARDS BOTH AT GROUND LEVEL AND OVERHEAD.**

- 1) Check proposed route for possible hazards, obstructions and personnel.
- 2) Depress foot switch located in platform floor (if applicable).
- 3) Use the **Drive Speed** selector on the platform control station to determine speed.  
**High Drive** (Hare) - GIVES HIGH SPEED AND LOW GRADEABILITY.  
**Low Drive** (Tortoise) - GIVES LOW SPEED AND HIGH GRADEABILITY.

**N.B.** High Drive is only available when the booms are in the stowed position. The HR15N will default Low Drive speed whenever the booms are elevated. Drive speed can only be changed when the joystick is in the neutral position.

- 4) Select drive joystick from the platform control box.
  - A. Up for **FORWARD**
  - B. Down for **REVERSE**

Steering is controlled by the rocker-switch button on the top of the joystick

- C. Left for **STEER LEFT**
- D. Right for **STEER RIGHT**

The driving horn is activated by the button on the front of the joystick and there is also a separate horn button on the platform controls for use when the drive and boom controls are switched off.

- 5) All control levers give a fully proportional response therefore the more the lever is moved away from the centre **Off** position the faster the function will become.
- 6) Maximum drive speed is only attainable when all booms are fully stowed and the **Drive Speed** selector is in the HI position.
- 7) When driving with the booms fully stowed, the Tilt Alarm is bypassed to allow the Niftylift to be driven in areas where the slope exceeds the five-degree working limit. In normal operation the drive is therefore unaffected when driven onto a slope in excess of five degrees, until the booms are raised, whereupon the drive would be disabled and the tilt alarm sounds continuously.



**ALL NIFTYLIFTS ARE FITTED WITH A TILT ALARM - PRE-SET IN THE FACTORY. ONCE ENERGISED THE NIFTYLIFT WILL LOSE ALL POWER TO DRIVE FUNCTIONS AND A LOUD AUDIBLE ALARM WILL BE ACTIVATED. TO DE-ACTIVATE, LOWER THE BOOMS FULLY TO STOWED POSITION AND RE-POSITION BASE ON FIRM, LEVEL GROUND.**

**Operating & Safety Instructions**

**IF ALARM SOUNDS - DESCEND IMMEDIATELY AND RE-LEVEL MACHINE BASE.**

**4.5 BATTERIES AND CHARGING**

**4.5.1 CHARGING**



**BATTERIES MUST BE RECHARGED IN A WELL-VENTILATED AREA FREE OF FLAME, SPARKS OR OTHER HAZARDS, WHICH MAY CAUSE EXPLOSION. HIGHLY EXPLOSIVE HYDROGEN GAS IS PRODUCED DURING THE CHARGING PROCESS.**

- 1) Recharge batteries at the end of every working day or shift.  
(**Note:** To recharge batteries fully from flat takes approx. 12 Hours, this consists of 8 hours bulk charging plus 4 hours equalisation).
- 2) Plug charger into suitable power supply, either 240 volts or 110 volts AC (see Section **4.5.2 Charging Limitations**). (Note: If using 240V, use of a suitably rated Earth Leakage Circuit Breaker (ELCB) or Residual Current Device (RCD) at the point of supply is highly recommended.)
- 3) Take note of the indicators provided:

Red Light- Batteries are charging.  
Pulsing Green light- the charge is equalising.  
Constant Green light and pulsing Red light- the batteries are fully charged.



**UNDER NO CIRCUMSTANCES SHOULD BATTERIES BE LEFT ON CHARGE FOR PERIODS IN EXCESS OF 24 HOURS**

- 4) **DISCONNECT FROM POWER SUPPLY ONCE BATTERIES ARE FULLY CHARGED.** The machine can now be left unattended, however, in the event of the machine being left unused for extensive periods then a **4 to 6 hour** 'top-up' charge every **4 weeks** is recommended. A 'top-up' charge the day before use ensures a full day of operation from the machine.



**UNDER NO CIRCUMSTANCES SHOULD A MACHINE BE LEFT FULLY DISCHARGED AS SEVERE BATTERY DAMAGE CAN OCCUR IN A RELATIVELY SHORT TIME.**

## Operating & Safety Instructions

- 5) To avoid damage to charger disconnect from mains supply before using machine.

### Note:

- 1) If the charger is reconnected to the power supply shortly after it has gone through its full charging cycle the Red LED may come on although the batteries may be fully charged. The charger would then go through its complete cycle again at an accelerated rate, depending on the time difference between connection, reconnection and level of battery charge.
- 2) Some Niftylifts are fitted with a Battery Management System, which permanently monitors the condition of the batteries. When the batteries become discharged to 80% of their capacity the management system will begin to “shut down” the hydraulic power packs. This causes the drive/boom operating system to alternately stop and start, signalling to the operator that re-charging is necessary. However, there is sufficient power remaining to enable the operator to drive slowly to the nearest charging point.

Should the operator ignore the onset of the battery discharge warning the “shut down” of the motors will continue, until the machine is rendered in-operative. **Immediate charging will then be required.**

### 4.5.2 CHARGING LIMITATIONS

Battery charging times will increase slightly if using a 110V supply as opposed to a 240V supply. This is due to the connection of the primary coils being in parallel, which in effect only allows the transformer to see 220V. Similarly, the capacity of the 110V supply will decide the input current available; hence a small hand-tool transformer will not operate the battery charger efficiently, therefore: - charging times will increase further due to input limitations.

Attention should also be given to the use of extension cables as power leads. Excessive cable lengths from the supply point to the battery charger will result in significant voltage drop, leading to a reduction in the chargers efficiency. In addition, inadequate sized cable cores will have a limiting effect on its current carrying capacity, which will again lead to a reduction in the chargers efficiency. Both of these can result in over-heating of the cable with the attendant risk of fire, short circuits or damage to the components themselves.

### 4.5.3 TOPPING UP

During the course of normal operation, the batteries should be inspected at least once a fortnight to check the level of electrolyte. During the end of charge, gassing takes place, which will cause a slight reduction in the volume of acid in the battery. This can be topped up with de-ionised water as required. During this inspection, it is useful to note any imbalance in the fluid levels. One indication of a faulty cell would be an increase in the loss of battery acid, which would then require more frequent topping up on that cell, or cells. Faulty cells can liberate excess hydrogen, even during normal operation, with the resulting risk of explosion if ignited. **Any faulty batteries should be replaced as soon as possible with an equivalent sized and rated unit.**

## **4.6 TRANSPORTING AND TOWING**

### **4.6.1 TRANSPORTING**

- Always ensure the truck or trailer you are loading the Niftylift onto can carry it legally.
- If loading by crane, lifting eyes are provided on the front and rear axles. The use of shackles and an adequately rated spreader beam, with four leg slings, is MANDATORY.
- If loading by forklift spread the forks to the widest extent between the wheels of the Niftylift, and lift from the side with a forklift of adequate capacity.
- Once positioned on the transport carrier a minimum of four ratchet straps should be used going front to back over the wheels
- Strap booms carefully to constrain them from sideways movement.
- Never lift any machine by its booms. Always secure chains or straps to the chassis.

### **4.6.2 TOWING – Hydraulic Drive motors**

Towing the Niftylift in case of an emergency. If necessary, chock the wheels before any of the following actions are taken.

In order to safely tow the HR15N, the drive mechanism and parking brakes will need to be bypassed.

- 1) In order to tow the Niftylift the drive gearboxes, located at the hubs of the rear wheels, must be disengaged.
- 2) To disengage gearboxes, disengage bolts, (24mm bolt in centre of rear hubs) must be turned anti-clockwise manually with a 24 A/F spanner. The bolt must be turned until 22mm of thread is exposed. The gearbox is now disengaged and the wheel will now rotate freely.
- 3) To re-engage gearboxes the disengage bolt must be rotated clockwise by 22mm until it is seated correctly against the gearbox housing. Under some circumstance the wheel may need to be rotated as the disengage bolt is being turned clockwise, this is due to the fact that the internal gear and spine need to be aligned in order to ensure correct mating. Under no circumstances must the disengage bolt be forced, as this will cause damage.
- 4) Under no circumstances must power tools or torque spanners be used to perform this operation, as this will result in serious damage to the gearbox.
- 5) Once gearboxes are disengaged the Niftylift can now be towed over short distances – maximum speed 5mph.

### **4.6.3 STORAGE**

If being stored for any length of time without use, then the machine should be thoroughly inspected for the following:-

- 1) Grease all bearings /slides, worm drives, etc.
- 2) Check batteries for electrolyte levels, state of charge, damage, dirt, etc. Never leave in a state of discharge for any length of time. If no use of the platform is intended, an occasional "top-up" charge of the batteries will serve to equalise their charge level.
- 3) Leave battery disconnect switch in OFF position to prevent discharge of batteries through leakage.
- 4) If machine is to be left on an incline, chock wheels to prevent creep.
- 5) If machine is to be left out-of-doors or in a hostile environment, cover with suitable weatherproof media to prevent deterioration.

### **4.6.4 SETTING TO WORK**

Before use each day and at the beginning of each shift the machine shall be given a visual and functional test including, but not limited to, the following

- 1) Check all lubrication points for adequate application of grease, oil etc.
- 2) Inspect all threads for ease of operation - especially descent valves, brake release valve etc.
- 3) Check level and quantity of oil. Remove any contaminants - water, etc.
- 4) Check batteries for electrolyte and state of charge.
- 5) Check electrics for damage and insulation.
- 6) Using ground controls, cycle machine over complete envelope in accordance with the Operating Instructions. Cure any defects.
- 7) Ensure that all safety devices and controls operate in accordance with the instructions.
- 8) If necessary, perform a load test to establish the machine stability before putting the machine to work.

## **5. Emergency Controls**

### **5.1 GENERAL**

**CHECKING THE OPERATION OF THE EMERGENCY CONTROLS EVERY DAY AND/OR BEFORE EACH SHIFT IS AN ESSENTIAL PART OF THE OPERATOR'S DUTIES**



The operator and all ground personnel must be thoroughly familiar with the location and operation of the emergency controls.

### **5.2. IN THE EVENT OF AN INCAPACITATED OPERATOR.**

Turn the key switch at the ground control station to **ground** (Anti-clockwise).  
Manoeuvre the machine using the ground controls as described in previous section (section 4.2).

### **5.3. IN THE EVENT OF MACHINE FAILURE.**

If all machine power is lost, the Emergency hand pump can be used to provide the hydraulic power to manoeuvre the machine.

- 1) Operate the emergency descent valves located under the base control panel on the superstructure. These must be pulled in or out depending on the direction of travel required. Refer to the decal inside the panel for the relevant controls.
- 2) With the relevant descent valve pushed in or pulled out operate the emergency hand pump, located inside the same panel.

**FOLLOWING AN EMERGENCY DESCENT RECOVERY OF THE PLATFORM, FULLY EXTEND AND RETRACT ALL CYLINDERS FROM GROUND CONTROL STATION BEFORE USING THE MACHINE.**



### **5.4 INCIDENT NOTIFICATION**

It is a mandatory requirement that any accident or incident involving a Niftylift, regardless of whether any party received injury or property was damaged is reported by telephone directly to Niftylift. Failure to do so may render any warranty on the machine void.

## **6. Responsibilities**

### **6.1 CHANGES IN OWNERSHIP**

When a change of ownership of a Niftylift occurs, it shall be the responsibility of the seller to notify Niftylift direct of the unit, model and serial number and the name and address of the new owner within 60 days. This important step is required so that all future Technical Bulletins are able to reach the registered owner of each machine without delay. Please note warranties are not transferable.

### **6.2 MANUAL OF RESPONSIBILITIES**

You are required by ANSI/SIA 92.2 1990, to read and understand your responsibilities before you use or operate this aerial platform. Please read the enclosed document, as failure to do so could result in death or serious injury. Wherever any contradiction may appear, the Manual of Responsibilities shall take precedence over all other documents.

### 6.3 Inspection/Service/Pre-Hire Check list

MACHINE SERIAL NO \_\_\_\_\_

<b>TOWING</b>	<b>PASS</b>	<b>FAIL</b>	<b>N/A</b>
Machine secured on trailer			
Straps correctly positioned and tightened			
Wheels chocked if necessary			
<b>AXLES, WHEELS AND BRAKES</b>			
Wheels are secure, tyre condition acceptable			
Wheel bearings O.K.			
Brake linkages and cables secure			
Brake shoe wear not excessive			
Machine climbs slope			
Brakes hold machine on slope			
Rear hub nut secure			
Track rod secure, not fouling axle plate			
<b>BASE</b>			
Operation of ground control valve and buttons			
Operation of all booms over full range			
Wheel bearings OK			
Cylinders are silent			
Platform is level over full range			
Booms, levelling rods not damaged or distorted			
Booms levelling rods, cylinders not fouling			
Hoses not tight, kinked or fouled			
Operation of emergency hand pump			
<b>SLEWING</b>			
Slew assembly and motor are secure			
Worm/wheel mesh correct, no excessive wear			
No end float of worm in housing			
Slew wheel bolts secure			
Slew guards secure			
<b>PLATFORM</b>			
Operation of control valve and buttons			
Levelling lock valve holds in both directions, lines vented			
Operation of all booms over full range			
Cylinders are silent			
Platform levelling over full range			
Slewing smooth over full range			
Operation of boom 4 over full range (if fitted)			
No excessive movement of boom 4 and boom 3			

**Operating & Safety Instructions**

<b>TILT ALARM</b>	<b>PASS</b>	<b>FAIL</b>	<b>N/A</b>
Booms raised on slope - drive disabled, siren tone constant			
Boom operation unaffected			
Booms lowered - drive restored			
<b>INTERNAL (POWER PACK)</b>			
Power pack and all components secure			
All cables and terminals secure			
All hose connections secure			
Hoses not kinked or fouled			
Charger/control box secure			
Batteries secure			
Electrolyte level and specific gravity			
Charger operation			
Hydraulic oil level			
Engine/Gear box oil			
<b>FINISH</b>			
Pivot pin tag bolts			
Correct decals, all visible			
Canopy/bonnets			
Grease nipples (Feet, Knuckle, Centre Post)			
<b>LEAK CHECK</b>			
Cylinders (Lift, Jacks, Telescope, Levelling)			
Control valves			
Check valves			
Power pack/pump			
Slew motor			
Hose connections			
Filter			
Wheel motors			

**Comments, remedial work required etc;**

**INSPECTED BY:** \_\_\_\_\_ **DATE:** / / 0