

Specifications

Model	Z-45/25J RT	
Measurements	Metric	US
Working height maximum*	15.86 m	51 ft 6 in
Platform height maximum	13.86 m	45 ft 6 in
Horizontal reach maximum	7.52 m	24 ft 8 in
Up and over clearance maximum	7.14 m	23 ft 5 in
A Platform length	0.76 m	2 ft 6 in
B Platform width	1.83 m	6 ft
C Height - stowed	2.13 m	7 ft
D Length - stowed	6.65 m	21 ft 10 in
E Width	2.29 m	7 ft 6 in
F Wheelbase	2.03 m	6 ft 8 in
G Ground clearance - center	0.37 m	1 ft 3 in

Productivity

Lift capacity	227 kg	500 lbs
Platform rotation	160°	160°
Vertical Jib rotation	135°	135°
Turntable rotation	355° non-continuous	
Turntable tailswing	zero	zero
Drive speed - stowed	7.24 km/h	4.5 mph
Drive speed - raised **	1.00 km/h	0.61 mph
Gradeability - 4WD - stowed***	45%	45%
Turning radius - inside	1.68 m	5 ft 6 in
Turning radius - outside	4.50 m	14 ft 9 in
Controls	12 V DC proportional	
Tyres	315/22 D020	

Power

Power source Deutz diesel D2011L03i 3 cylinder diesel 35.8 kW (48 hp)

Auxiliary power unit	12 V DC	
Hydraulic tank capacity	83 L	22 gal
Fuel tank capacity	64.4 L	17 gal

Sound & Vibration Levels

Sound pressure level (ground workstation)	87 dBA	87 dBA
Sound pressure level (platform workstation)	82 dBA	82 dBA
Vibration	<2.5 m/s ²	<8 ft 2 in/s ²

Weight****

CE 4WD (foam filled tyres)	6,460 kg	14,244 lbs
----------------------------	----------	------------

Standards Compliance

EU Directives: 2006/42/EC - Machinery Directive
Harmonized Standards: EN280; 2004/108/EC (EMC);
2000/14/EC (Outdoor Noise)

Range Of Motion Z-45/25J RT

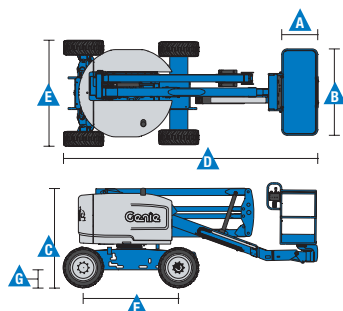
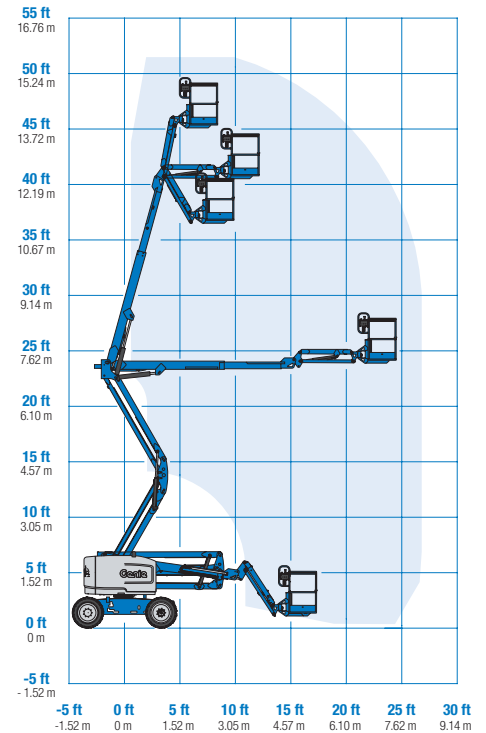

* The metric equivalent of working height adds 2 m to platform height. U.S. adds 6 ft to platform height.
** In lift mode (platform raised), the machine is designed to operate on firm, level surfaces only.
*** Gradeability applies to driving on slopes. See operator's manual for details regarding slope ratings.
**** Weight will vary depending on options and/or country standards.

Features

Standard Features	Easily Configured To Meet Your Needs	Options & Accessories
<p>Measurements</p> <ul style="list-style-type: none"> • 15.86 m (51 ft 6 in) working height • 7.52 m (24 ft 8 in) horizontal reach • 7.14 m (23 ft 5 in) up and over clearance • Up to 227 kg (500 lbs) lift capacity <p>Productivity</p> <ul style="list-style-type: none"> • Self-leveling platform • Hydraulic platform rotation • Proportional joystick controls • Telematics-Ready Connector • Hydraulic oil cooler • Thumb rocker steering • Drive enable • Chassis tilt drive function cut-out • AC power cord to platform • Horn • Hour meter • Tilt alarm • Descent & travel alarms • Flashing beacon • 355° non-continuous turntable rotation • Positive traction drive • Two speed wheel motors • Zero tailswing • Dual parallelogram for vertical wall tracking • Lift Guard™ Contact Alarm <p>Power</p> <ul style="list-style-type: none"> • 12 V DC auxiliary power • Deutz intake air heater • Swing out engine tray 	<p>Platform</p> <ul style="list-style-type: none"> • Steel 1.83 m (6 ft) dual entry with side swing gate <p>Jib</p> <ul style="list-style-type: none"> • Articulating 1.52 m (5 ft) jib boom <p>Power</p> <ul style="list-style-type: none"> • Deutz diesel 35.8 kW (48 hp) <p>Drive</p> <ul style="list-style-type: none"> • 4 x 4 <p>Axle</p> <ul style="list-style-type: none"> • Active oscillation (standard) <p>Tyre Options</p> <ul style="list-style-type: none"> • Rough terrain foam-filled (standard) • Rough terrain non-marking (foam-filled) 	<p>Productivity</p> <ul style="list-style-type: none"> • Half-mesh platform • Platform auxiliary top rail • Power to platform: plug, socket, with optional Residual-current Circuit Breaker with Overcurrent protection • Work lights package (2 on chassis, 2 on platform) ⁽¹⁾ • Biodegradable hydraulic oil • Hostile environment kit ⁽¹⁾: cylinder bellows, boom wiper seals and platform control box covers • Aircraft protection kit ^(1,4): platform foam padding and padded disable system • Chassis tilt lift function cut-out (software setting) • Track & Trace ⁽²⁾ (GPS unit providing machine location & operating information) • Lockable platform control box cover • Tool Tray ⁽³⁾ • Operator Protective Structure ⁽³⁾ • Fall Arrest Bar ⁽³⁾ <p>Power</p> <ul style="list-style-type: none"> • Diesel catalytic scrubber muffler ⁽¹⁾ • Engine gauge package (oil pressure & temperature and voltage) ⁽¹⁾ • AC generator packages (110V/60Hz - 220V/50Hz, 2200W) • Low temperature cut-out module • EMEAR Cold Start kit: Inc. Engine heater & battery charger • Cold weather packages ⁽¹⁾



⁽¹⁾ Factory-fit option only
⁽²⁾ Includes a first 2 years subscription
⁽³⁾ Aftermarket only
⁽⁴⁾ Reduces load capacity of about 27 kg (60 lb). Only available with 1.83 m (6 ft) platform, not available with any other platforms nor options on the platform

United Kingdom and MESART

The Maltings, Wharf Road, Grantham NG31 6BH, T: +44 800 988 3739 (toll free), Fax +44 (0)1476 584334, Email AWP-InfoEurope@terex.com
 Middle East, Southern Africa, Russia and Turkey, T: +971 4 399 0381, Email AWP-InfoME@terex.com
 Visit www.genielift.com/en-gb/about-genie/locations to view our global locations list.

Worldwide Manufacturing And Distribution

Australia · Brazil · Caribbean · Central America · China · France · Germany · Italy · Japan · Korea · Mexico · Russia · Southeast Asia · Spain · Sweden · United Arab Emirates · United Kingdom · United States

Product specifications and prices are subject to change without notice or obligation. The photographs and/or drawings in this document are for illustrative purposes only. Refer to the appropriate Operator's Manual for instructions on the proper use of this equipment. Failure to follow the appropriate Operator's Manual when using our equipment or to otherwise act irresponsibly may result in serious injury or death. The only warranty applicable to our equipment is the standard written warranty applicable to the particular product and sale and we make no other warranty, express or implied. Products and services listed may be trademarks, service marks or trade names of Terex Corporation and/or their subsidiaries in the USA and many other countries. Genie is a registered trademark of Terex South Dakota, Inc. © 2019 Terex Corporation.

