

Operator's Manual

with Maintenance Information

JCPT2825RT
JCPT3225RT

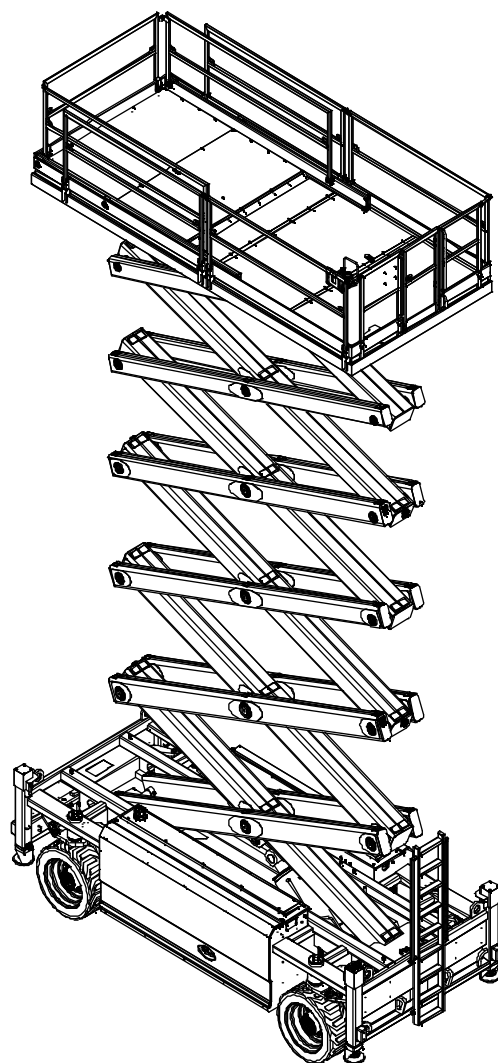

Part Number: SM012110141
Version Number: Rev1.1
July 2022 Printing

Original Instructions

Version of the Record

Version of the Record

Version Number	Create Date
SM012110141_Rev1.0	2022-07
SM012110141_Rev1.1	2022-08

Introduction

Important

Read, understand and obey these safety rules and operating instructions before operating this machine.

Only trained and authorized personnel shall be permitted to operate this machine. This manual should be considered a permanent part of your machine and should remain with the machine at all times. If you have any questions, please call DINGLI Machinery.

Identification of the Manual

The identification code of the Manual is shown on the cover; it is advisable to note this down in the Inspection Register.

If the Manual is lost, to request a new Manual, mention the code on the cover or the manufacturing number of the machine.

It is advisable to mention the machine manufacturing number on the cover in such a way as to clearly identify the Manual with the machine.

Owners, Users and operators:

We appreciate your choice of our machine for your application. Our number one priority is user safety, which is best achieved by our joint efforts. We feel that you make a major contribution to safety if you, as the equipment users and operators:

- 1 Comply with employer, job site and governmental rules.
- 2 Read, understand and follow the instructions in this and other manuals supplied with this machine.
- 3 Use good safe work practices in a commonsense way.
- 4 Only have trained / certified operators, directed by informed and knowledgeable supervision, running the machine.

If there is anything in this manual that is not clear or which you believe should be added, please contact us.

Introduction

Contents

	Page
Safety Rules	1
Legend	9
Decals	10
Specifications	17
Controls	19
Pre-operation Inspection	24
Workplace Inspection	26
Function Tests	27
Operating Instructions	32
Transport and Lifting Instructions	40
Maintenance	43
Schematic	73
Inspection and Repair Log	77

Contact us:

Zhejiang Dingli Machinery Co., Ltd.

No.188 Qihang Road. Deqing Zhejiang P.R.

China 313219

Tel: +86-572-8681688

Fax: +86-572-8681690

Web: www.cndingli.com

E-mail: market@cndingli.com

Safety Rules



Danger

Failure to obey the instructions and safety rules in this manual will result in death or serious injury.

Do Not Operate Unless:

- You learn and practice the principles of safe machine operation contained in this operator's manual.
 - 1 **Avoid hazardous situations.**
 - Know and understand the safety rules before going on to the next section.**
 - 2 Always perform a pre-operation inspection.
 - 3 Always perform function tests prior to use.
 - 4 Inspect the workplace.
 - 5 Only use the machine as it was intended.
- You read, understand and obey the manufacturer's instructions and safety rules — operator's manual and machine decals.
- You read, understand and obey employer's safety rules and worksite regulations.
- You read, understand and obey all applicable governmental regulations.
- You are properly trained to safely operate the machine.

Hazard Classification

DINGLI product decals use symbols, color coding and signal words to identify the following:



Safety alert symbol — used to alert personnel to potential personal injury hazards. Obey all safety messages that follow this symbol to avoid possible injury or death.

▲ DANGER

Red — used to indicate the presence of an imminently hazardous situation which, if not avoided, will result in death or serious injury.

▲ WARNING

Orange — used to indicate the presence of a potentially hazardous situation which, if not avoided, could result in death or serious injury.

▲ CAUTION

Yellow with safety alert symbol — used to indicate the presence of a potentially hazardous situation which, if not avoided, may cause minor or moderate injury.

NOTICE

Blue without safety alert symbol — used to indicate the presence of a potentially hazardous situation which, if not avoided, may result in property damage.

Safety Rules

The relevant conditions of using the equipment

The surface of work ground should be flat and hard with no obstacles in air and the safety distance between the equipment and high-tension line is adequate.

The environment temperature should be within $-20^{\circ}\text{C} \sim 40^{\circ}\text{C}$; Height above sea level $\leq 1000\text{m}$.

The environment humidity $\leq 90\%$.

Electrical power: AC $110 \sim 230\text{V} \pm 10\%$, $50 \sim 60\text{Hz}$.

Work cycle

The life of designed work cycle is no more than 40000 times.

Intended Use

This machine is intended to be used only to lift personnel, along with their tools and materials to an aerial work site.

Safety Sign Maintenance

Replace any missing or damaged safety signs. Keep operator safety in mind at all times. Use mild soap and water to clean safety signs. Do not use solvent-based cleaners because they may damage the safety sign material.

Operator

Only the trained and qualified are permitted to operate this machine. Always use safety belt and helmet when aerially working.

If you are subject to dizziness or seizures, or are bothered by heights, you must not operate

this type of machinery.

An operator must not use drugs or alcohol that can change his/her alertness or coordination.

An operator on prescription or over-the-counter drugs needs medical advice on whether or not he/she can safely operate machines.

⚠ Electrocutation Hazard

This machine is not electrically insulated and will not provide protection from contact with or proximity to electrical current.

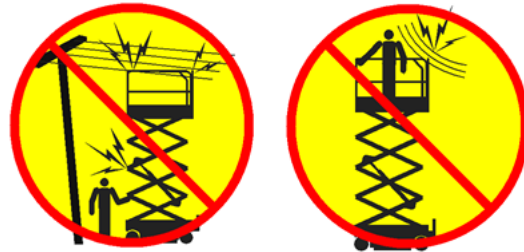

Maintain safe distances from electrical power lines and apparatus in accordance with applicable governmental regulations and the following chart.

Voltage Phase to Phase	Minimum Safe Approach Distance Meters
0 to 300V	Avoid Contact
300V to 50kV	3.05
50kV to 200kV	4.60
200kV to 350kV	6.10
350kV to 500kV	7.62
500kV to 750kV	10.67
750kV to 1000kV	13.72

Allow for platform movement, electrical line sway or sag and beware of strong or gusty winds.

Safety Rules

Keep away from the machine if it contacts energized power lines. Personnel on the ground or in the platform must not touch or operate the machine until energized power lines are shut off.

Do not operate the machine during lightning or storms.

Do not use the machine as a ground for welding.

▲ Tip-over Hazard

Occupants, equipment and materials must not exceed the maximum platform capacity or the maximum capacity of the platform extension.

Maximum capacity – JCPT2825RT

Maximum occupants	4
Platform allowable maximum load	1000kg

Maximum capacity – JCPT3225RT

Maximum occupants	4
Platform allowable maximum load	1000kg

Work Area Safety

Do not raise the platform unless the machine is on a firm, level surface.

Do not drive over 0.3km/h with the platform raised.



Do not depend on the tilt alarm as a level indicator. The tilt alarm sounds on the chassis and in the platform when the machine is on a slope.

If the tilt alarm sounds:

Lower the platform. Move the machine to a firm, level surface. If the tilt alarm sounds when the platform is raised, use extreme caution to lower the platform.

For outdoor use machine, Do not raise the platform when wind speeds may exceed 12.5 m/s. If wind speeds exceed 12.5 m/s when the platform is raised, lower the platform and do not continue to operate the machine.

Do not operate the machine in strong or gusty winds. Do not increase the surface area of the platform or the load. Increasing the area exposed to the wind will decrease machine stability.



Do not use the platform controls to free a platform that is caught, snagged or otherwise prevented from normal motion by an adjacent structure. All personnel must be removed from the platform before attempting to free the platform using the ground controls.

Use extreme care and slow speeds while driving the machine in the stowed position across uneven terrain, debris, unstable or slippery surfaces and near holes and drop-offs.

Do not drive the machine on or near uneven terrain, unstable surfaces or other hazardous conditions with the platform raised.

Do not push off or pull toward any object outside of the platform.

Safety Rules



Maximum allowable manual force

Model	Application	Manual force	Maximum occupants
JCPT2825RT	Outdoor	400N	4
	Indoor	400N	4
JCPT3225RT	Outdoor	400N	4
	Indoor	400N	4

Do not use the machine as a crane.

Do not place or attach fixed or overhanging loads to any part of this machine.

Do not push the machine or other objects with the platform.

Do not contact adjacent structures with the platform.

Do not alter or disable the limit switches.

Do not tie the platform to adjacent structures.

Do not place loads outside the platform perimeter.



Do not alter or disable machine components that in any way affect safety and stability.

Do not replace items critical to machine stability with items of different weight or specification.

Do not modify or alter an aerial work platform without prior written permission from the manufacturer. Mounting attachments for holding tools or other materials onto the platform, toe boards or guard rail system can increase the weight in the platform and the surface area of the platform or the load.

Do not place ladders or scaffolds in the platform or against any part of this machine.

Do not transport tools and materials unless they are evenly distributed and can be safely handled by person(s) in the platform.

Do not use the machine on a moving or mobile surface or vehicle.

Be sure all tires are in good condition, air-filled tires are properly inflated and lug nuts are properly tightened.

▲ Crushing Hazard

Keep hands and limbs out of scissors.

Keep hands clear when folding rails.

Use common sense and planning when operating the machine with the controller from the ground. Maintain safe distances between the operator, the machine and fixed objects.

Maintain a firm grasp on the platform rail when removing the rail pins. Do not allow the platform guard rails to fall.

▲ Operation on Slopes Hazard

Do not drive the machine on a slope that exceeds the slope and side slope rating of the machine.

Slope rating applies to machines only in the stowed position.

Safety Rules

Model	Maximum slope rating stowed position	Maximum side slope rating stowed position
JCPT2825RT	40% (22°)	30% (17°)
JCPT3225RT	40% (22°)	30% (17°)

Note: Slope rating is subject to ground conditions and adequate traction.

▲ Fall Hazard

The guard rail system provides fall protection. If occupant(s) of the platform are required to wear personal fall protection equipment (PFPE) due to job site or employer rules, PFPE equipment and its use shall be in accordance with the PFPE manufacturer's instructions and applicable governmental requirements.



Do not sit, stand or climb on the platform guard rails. Maintain a firm footing on the platform floor at all times.



Do not climb down from the platform when raised.

Keep the platform floor clear of debris.

Close the entry gate before operating.

Do not operate the machine unless the guard rails are properly installed and the entry is secured for operation.

Do not enter or exit the platform unless the machine is in the stowed position.

▲ Collision Hazard



Be aware of limited sight distance and blind spots when driving or operating.

Be aware of extended platform position(s) when moving the machine.

Check the work area for overhead obstructions or other possible hazards.



Be aware of crushing hazards when grasping the platform guard rail.

Operators must comply with employer, job site and governmental rules regarding use of personal protective equipment.

Observe and use color-coded direction arrows on the platform controls and platform decal plate for drive and steer functions.

Do not operate a machine in the path of any crane or moving overhead machinery unless the controls of the crane have been locked out and/or precautions have been taken to prevent any potential collision.

No stunt driving or horseplay while operating a machine.

The guard rail able to grip to protect the hands not being busy operating from the danger of crush, are as follows in the follow figure.

Safety Rules

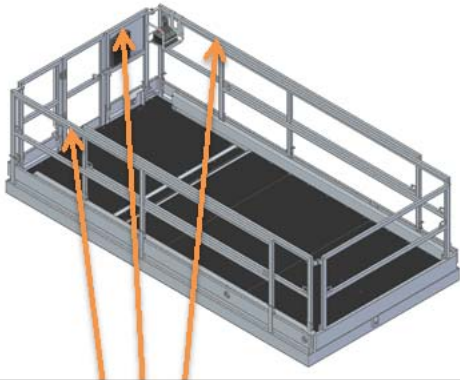

Guard rail protecting hands from danger

Do not lower the platform unless the area below is clear of personnel and obstructions.



Limit travel speed according to the condition of the ground surface, congestion, slope, location of personnel, and any other factors which may cause collision.

⚠ Component Damage Hazard

Do not use any battery or charger greater than 12V to jump-start the engine.

Do not use the machine as a ground for welding.

⚠ Explosion and Fire Hazard

Do not start the engine if you smell or detect liquid petroleum gas (LPG), gasoline, diesel fuel or other explosive substances.

Do not refuel the machine with the engine running.

Refuel the machine and charge the battery

only in an open, well-ventilated area away from sparks, flames and lighted tobacco.

Do not operate the machine in hazardous locations or locations where potentially flammable or explosive gases or particles may be present.

Do not spray ether into engines equipped with glow plugs.

⚠ Damaged Machine Hazard

Do not use a damaged or malfunctioning machine.

Conduct a thorough pre-operation inspection of the machine and test all functions before each work shift. Immediately tag and remove from service a damaged or malfunctioning machine.

Be sure all maintenance has been performed as specified in this manual. Be sure all decals are in place and legible.

Be sure the operator's manual is complete, legible and in the storage container located in the platform.

⚠ Bodily Injury Hazard

Always operate the machine in a well-ventilated area to avoid carbon monoxide poisoning.

Do not operate the machine with a hydraulic oil or air leak. An air leak or hydraulic leak can penetrate and/or burn skin.

Improper contact with components under any cover will cause serious injury. Only trained maintenance personnel should access compartments. Access by the operator is only advised when performing a pre-operation inspection. All compartments must remain closed and secured during operation.

Safety Rules

▲ Outrigger Safety

Do not lower the outriggers unless the machine is on a firm surface. If the ground does not meet the requirements specified of the relevant regulations, sufficient ground preparation shall be carried out in advance to confirm its safety before operation. Avoid drop-offs, holes, unstable or slippery surfaces and other possible hazardous conditions.

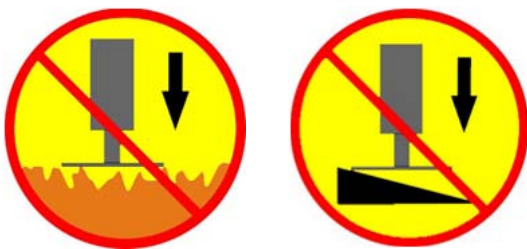

In case of special (soft or inclined) ground, the wood or steel pad suitable for the ground must be used under the support plate, and it must be firm and not cave in during the operation.

When using the backing plate, the backing plate must be of a solid structure that can fully withstand the pressure of the supporting leg. If the steel plate is set under the support plate, it should be used with small deformation.

When the auto level function is not being used and the outriggers are being lowered individually, the steer-end outriggers must be lowered first.

Do not raise the platform unless the machine is level. Do not set the machine up on a surface where it cannot be leveled using only the outriggers.

Do not raise the platform unless all four outriggers are properly lowered, the footpads are in firm contact with the ground and the machine is level.

Do not adjust the outriggers while the platform is raised.

Do not drive while the outriggers are lowered.

▲ Battery Safety

▲ Burn Hazard

Batteries contain acid. Always wear protective clothing and eye wear when working with batteries.



Avoid spilling or contacting battery acid. Neutralize battery acid spills with baking soda and water.

▲ Explosion Hazard



Keep sparks, flames and lighted tobacco away from batteries. Batteries emit explosive gas.

▲ Electrocuting/ Hazard

Avoid contact with electrical terminals.

▲ pollute Hazard

Dispose of old battery must comply with job site and governmental rules.

Safety Rules

Lockout after Each Use

- 1 Select a safe parking location - firm level surface, clear of obstructions and traffic.
- 2 Lower the platform.
- 3 Turn the key switch to the off position and remove the key to secure from unauthorized use.
- 4 Push in the red Emergency Stop buttons to "off" position.
- 5 Push in the main power switch to "off" position.
- 6 Chock the wheels.

Legend

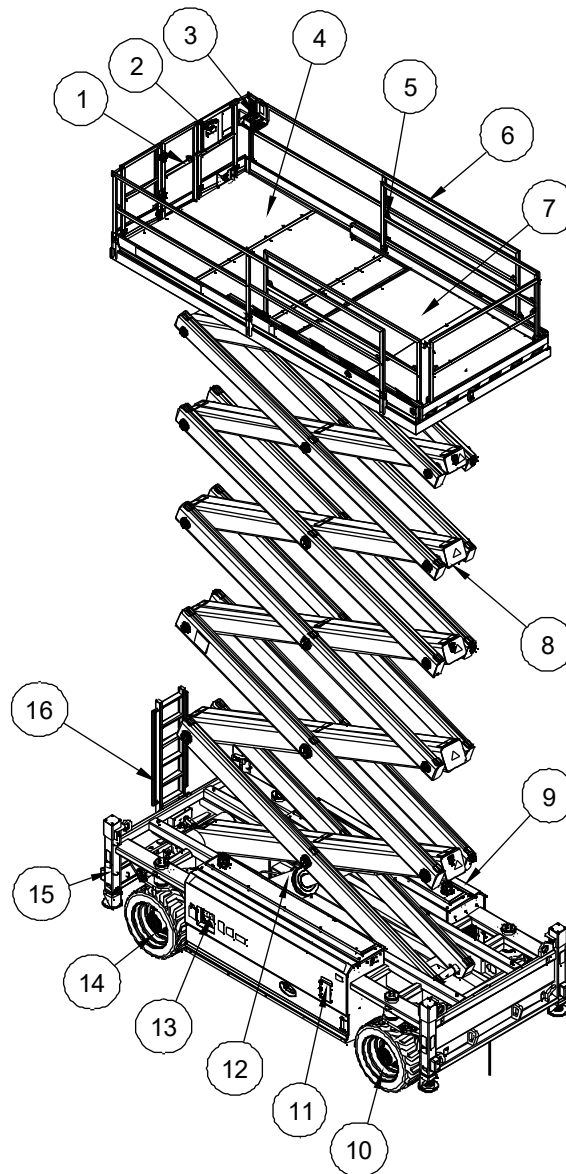

- | | |
|-----------------------------|-----------------------------------------------|
| 1 Platform entry gate | 9 Engine(behind cover) |
| 2 Manual storage containers | 10 Rear wheel |
| 3 Platform controls | 11 Hydraulic tanks, Fuel tanks (behind cover) |
| 4 Main Platform | 12 Lift Cylinder |
| 5 Lanyard anchorage point | 13 Ground controls |
| 6 Platform guard rails | 14 Front wheel |
| 7 Platform extensions | 15 Outrigger |
| 8 Scissor Arms | 16 Entry ladder |

Decals

Decal Inspection

Use the pictures on the next page to verify that all decals are legible and in place.

Below is a numerical list with quantities and descriptions.

No.	Part No.	Description	Qty.	Remark
1	09340001	Decal, Notice-Keep the manual with the machine	1	
2	09440119	Decal, Danger-Tip-over hazard, tilt-alarm	1	
3	09440001	Decal, Danger-General safety rules	1	
4	09340070	Decal, Symbols-Non operating hand position	3	
5	09340003	Decal, Instructions-Refer the operator to the instructions for use	2	
6	09440011	Decal, Label-Lanyard anchorage point	8	
7	09440212	Decal, Warning-Crushing hazard	2	
8	09430007	Decal, Symbols-Crushing hazard	10	
9	09310049	Decal, Instructions-Lift point	4	
10	09420005	Decal, Warning-Collision hazard	4	
11	09310050	Decal, Instructions-Tie down point	4	
12	09410069	Decal, Warning-Crushing hazard, outrigger	4	
13	09310498	Decal, Instructions-Maximum outrigger load 8300kg	4	JCPT2825RT
	09310500	Decal, Instructions-Maximum outrigger load 10000kg	4	JCPT3225RT
14	09410157	Decal, Symbols-Outrigger using warning	4	
15	09310497	Decal, Instructions-Maximum wheel load 8300kg	4	JCPT2825RT
	09310499	Decal, Instructions-Maximum wheel load 10000kg	4	JCPT3225RT
16	09320003	Decal, Instructions-Diesel	2	
17	09540001	Decal, Label-CE	2	
18	09310148	Decal, Instructions-Emergency	1	

Decals

No.	Part No.	Description	Qty.	Remark
19	09410071	Decal, Warning-Injection hazard	1	
20	09410001	Decal, Danger-Explosion/burn hazard	1	
21	09410003	Decal, Warning-Inspected and operation properly	1	
22	09910094	Decal, Label-JCPT2825RT	2	JCPT2825RT
	09910096	Decal, Label-JCPT3225RT	2	JCPT3225RT
23	09410005	Decal, Danger-Do not alter or disable limit switch	1	
24	09330012	Decal, Instructions-Grease filling port	1	
25	09440007	Decal, Caution-Max. manual force 400N	2	
26	09640211	Decal, Cosmetic-JCPT2825RT	2	JCPT2825RT
	09640213	Decal, Cosmetic-JCPT3225RT	2	JCPT3225RT
27	09440434	Decal, Label-Capacity 1000kg	1	
28	09410136	Decal, Caution-Main power switch operation	1	
29	09310508	Decal, Instructions-Grease filling port	1	
30	09310510	Decal, Instructions-Grease filling port	1	
31	09310054	Decal, Instructions-Hydraulic	1	
32	09310052	Decal, Instructions-Highest oil level	1	
33	09310053	Decal, Instructions-Lowest oil level	1	
34	09420011	Decal, Caution-High temperature	1	
35	09330010	Decal, Instructions-Grease filling port	1	
36	09310501	Decal, Symbols-Emergency operating instructions	1	

Decals

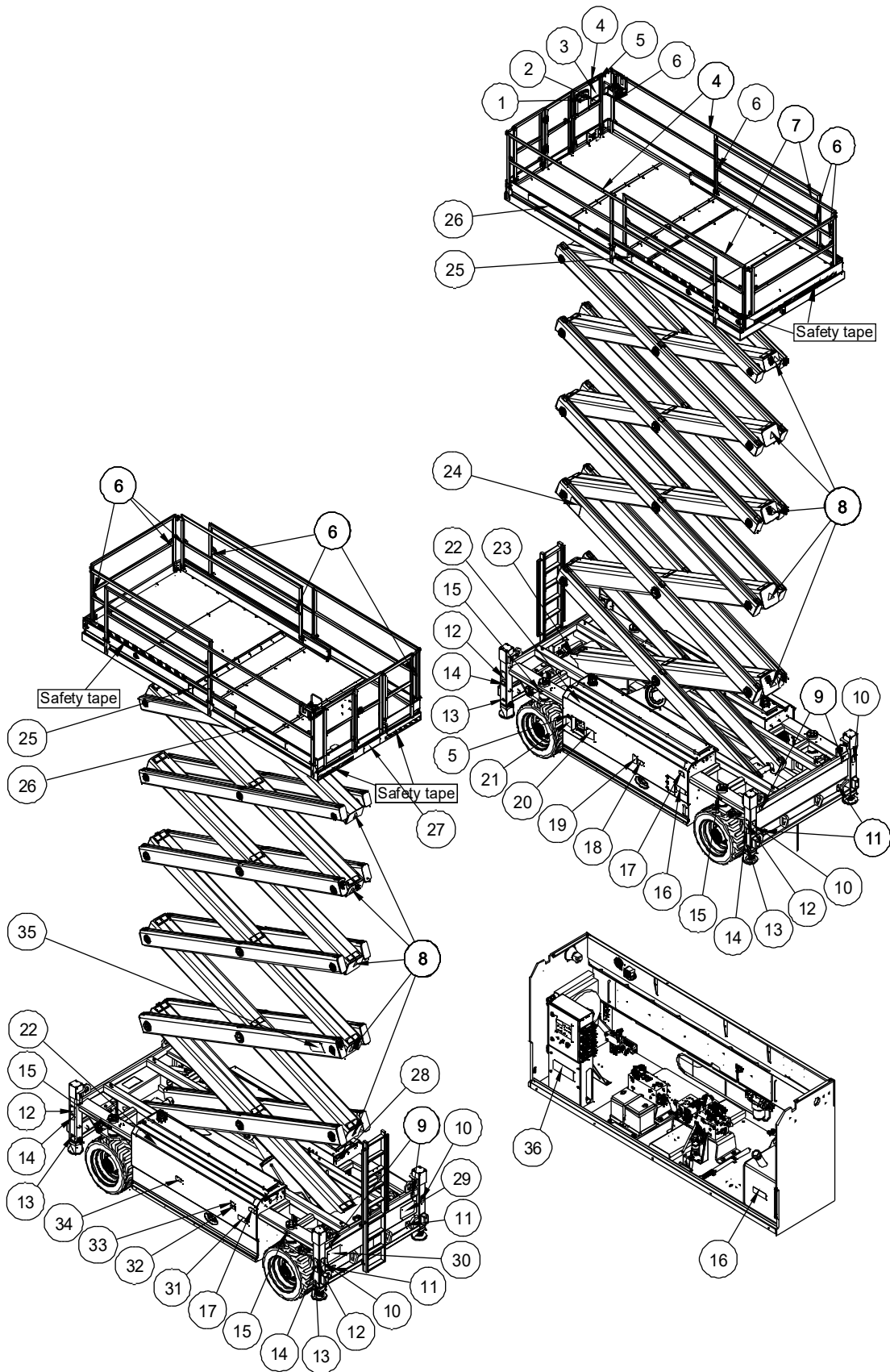

JCPT2825RT

① 09340001

NOTICE

KEEP THE OPERATION AND SAFETY MANUAL WITH THE MACHINE

② 09440119

⚠ DANGER

Tip-over Hazard

The outriggers must be used when the ground angle is out of machine maximum allowed working angle.

Do not set up where it can't be leveled with outriggers.

If tilt-alarm sounds, until it on a severe slope. Death or serious injury could occur.

1 Lower the platform. 2 Move the machine to level surface.

④ 09340070



③ 09440001

⚠ DANGER

Failure to read, understand and obey the operator's manual and the following safety rules will result in death or serious injury.

Improper Use Hazard

- Avoid hazardous situations.
- Always perform a pre-operation inspection.
- Always perform function tests prior to use.
- Avoid work slope.
- Only use the machine as it was intended.

Do not operate unless you are properly trained to safely operate this machine or you read, understand and follow:

- Manufacturer's instructions and safety rules.
- Operator's manuals and decals.
- Applicable safety laws.
- Applicable governmental regulations.

Electrocution Hazard

This machine is not electrically insulated and will not provide protection from contact with or proximity to electrical current.

Voltage	Minimum Safe Approach Distance (feet) or (meters)	Assault Contact
120 V to 250 V	3.00 (0.91)	4.00 (1.22)
250 V to 500 V	4.00 (1.22)	5.00 (1.52)
500 V to 1000 V	5.00 (1.52)	6.50 (1.98)
1000 V to 1500 V	6.50 (1.98)	8.00 (2.44)
1500 V to 2000 V	8.00 (2.44)	10.00 (3.05)
2000 V to 3000 V	10.00 (3.05)	13.00 (3.96)
3000 V to 10000 V	13.00 (3.96)	18.00 (5.49)

Tip-over Hazard

- Do not exceed rated load capacity.
- Do not raise platform unless machine is on a firm surface.
- Avoid drop-offs, holes and unstable or slippery surfaces.
- Do not raise platform unless machine is on a firm surface.
- Do not raise platform unless machine is on a firm surface.
- Do not drive machine on a steep or uneven terrain, unstable surfaces or other hazardous conditions with the platform raised.
- Do not push off or pull toward any object not part of the platform.
- Do not place or attach attachments to any part of this machine.
- Use slow speed and slow speeds while driving the machine in slippery conditions unless terrain, debris, unstable or slippery surfaces and near trees and drop-offs.

Fall Protection

Manufacturer's requirements that all persons on the platform wear a full body harness with a lanyard attached to an authorized tie-off anchor point while operating this machine.

For outdoor use, machine:

- All fall lines are in good condition, secure, rated, and properly tightened and other pins are properly installed.
- Do not raise platform when wind speeds may exceed 12 mph.
- Do not operate machine in strong or gusty winds.
- Do not increase surface area of platform or load. Increasing area exposed to wind will decrease machine stability.

Fall Hazard

When in operation, ensure all gates and rails are latched and secured in their proper position.

- Do not sit, stand or lean on the platform guard rails.
- Do not lean against the platform at any time.
- Do not climb down from the platform when raised.

Crushing Hazard

Keep hands and limbs out of rollers. Use caution when and whenever any operating machine with controller from ground.

Collision Hazard

- Be aware of limited sight distance and blind spots when driving or operating.
- Check work area for overhead obstructions or other possible hazards.
- Be aware of crushing hazard when grasping platform guard rail.
- Observe and use direction arrows on the platform controls for drive and travel functions.
- Do not use a damaged or malfunctioning machine.
- Be sure of maintenance has been performed as specified in the appropriate operator's manual.
- Be sure all decals are in place and legible.
- Be sure safety, operator's manual is complete, legible and in the storage container located on the platform.

⑥ 09440011



⑦ 09440212



⑧ 09430007



⑨ 09310049



⑩ 09420005

⚠ WARNING



⑫ 09410069

⚠ WARNING

Crushing Hazard

Lowering the outriggers or fins onto a person's foot can result in serious injury.

Keep clear of outriggers and lines before lowering.

⑪ 09310050



⑭ 09410157



⑮ 09310497

8300 kg
18260 lbs

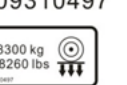

⑰ 09540001



⑱ 09310148

Emergency!

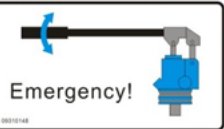

⑲ 09410071

⚠ WARNING

Injection Hazard

Escaping fluid under pressure can penetrate skin, causing serious injury.

Relieve pressure before disconnecting hydraulic lines. Keep away from leaks and pin holes. Use a piece of cardboard or paper to search for leaks. Do not use hand. Fluid injected into skin must be surgically removed within a few hours by a doctor familiar with this type of injury or gangrene will result.

⑳ 09410001

⚠ DANGER

Explosion/Burn Hazard

Do not operate the machine or charge the batteries in hazardous locations where potentially flammable or explosive gases or particles may be present. Ignition of explosive gases or contact corrosive acid will cause death, burns or blindness.

Keep all open flames and sparks away. Wear personal protective equipment, including face shield, gloves and long sleeve shirt.

Read Manuals
Read all manuals prior to operation.

DO NOT OPERATE equipment if you do not understand the information in the manuals. Consult your supervisor, the owner or the manufacturer.

㉑ 09410003

⚠ WARNING

THIS MACHINE MUST NOT BE USED UNTIL IT IS INSPECTED AND OPERATING PROPERLY.

1. Do not operate this machine unless you have been properly trained by a qualified person and authorized to operate this machine. Your training includes reading and understanding the safety, operating and maintenance instructions in manufacturer's manuals, knowing your employer's work rules and applicable governmental regulations.
2. Follow the instructions in the Operating Manual and applicable standards for daily, frequent, and annual inspections.
3. Do not replace items (i.e., batteries, wheels, counterweight, etc.) with items of different weight or specification because this will affect stability of machine.
4. Do not modify or change machine without written approval from manufacturer.
5. Operate this machine with extreme caution. STOP all operation if malfunction occurs.
6. Improper use of this machine could cause death or serious injury.

㉒ 09910094

⚠ CAUTION

Max. Manual Force

400N



㉓ 09410005

⚠ DANGER

Tip-over Hazard

Altering or disabling limit switches can result in machine tip-over. Machine tip-over will result in death or serious injury. Do not alter or disable limit switches.

DIESEL

JCPT2825RT : 4x4 SELF-PROPELLED ROUGH-TERRAIN SCISSOR LIFTS

Decals

JCPT2825RT

②④ 09640211

JCPT2825RT

②⑤ 09440434

②⑥ 09410136

CAUTION

Don't cut off the main power until the engine has been stopped for two minutes.

ON

OFF

②② 09330012

②⑦ 09310508

②⑧ 09310510

③③ 09330010

②⑨ 09310054

HYDRAULIC

③① 09310053

③② 09420011

CAUTION

HIGH TEMPERATURE DO NOT TOUCH.

③④ 09310052

③④ 09310501

JCPT3225RT

① 09340001

NOTICE

KEEP THE OPERATION AND SAFETY MANUAL WITH THE MACHINE

② 09440119

DANGER

Tip-over Hazard



The outriggers must be used when the ground angle is out of machine maximum allowed working angle. Do not set up where it can't be leveled with outriggers.

If tilt alarm sounds, 1. Lower the platform, 2. Move the machine to level surface. Death or serious injury could occur.

④ 09340070



⑤ 09340003

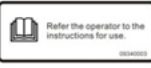

Refer the operator to the instructions for use.

③ 09440001

DANGER

Failure to read, understand and obey the operator's manual and the following safety rules will result in death or serious injury.

Improper Use Hazard

- Do not alter or disable machine components that in any way affect safety and stability.
- Do not place operator or auxiliary on platform or auxiliary lift.
- Do not use machine on uneven or unstable surface or on uneven ground.
- Do not use machine on moving or mobile surface or vehicle.
- Be sure all tires are in good condition. Check nuts and properly tightened and adjust pins are properly installed.

For outdoor use machine:

- Do not raise platform when wind speeds may exceed 12 km/h.
- Do not operate machine in strong or gale winds.
- Do not increase surface area of platform or load. Increasing area exposed to wind will decrease machine stability.

For indoor use machine:

- Do not raise platform when wind speeds may exceed 12 km/h.
- Do not operate machine in strong or gale winds.
- Do not increase surface area of platform or load. Increasing area exposed to wind will decrease machine stability.

Fall Protection

• All persons on the platform wear a full body harness with a lanyard attached to an approved anchor point while operating this machine.

ALL PPE must comply with applicable government regulations and must be inspected and used in accordance with the manufacturer's instructions.

Fall Hazard

- When in operation, ensure all gates and ladders are latched and locked or their proper position.
- Do not sit, stand or climb on platform.
- Maintain a firm footing on the platform at all times.
- Do not climb down from the platform when raised.

Crushing Hazard

- Keep hands and limbs out of access. Use common sense and planning when operating machine with counter from ground.
- Maintain safe distance between operator, machine and fixed objects.

Collision Hazard

- Be aware of limited sight distance and blind spots when driving or operating.
- Check work area for overhead obstructions or other possible hazards.
- Be aware of crushing hazard when grasping platform guard rail.
- Clean and use direction arrows on the platform for time and clear functions.

Damaged Machine Hazard

- Do not use a damaged or malfunctioning machine.
- Do not use components that have been replaced or modified in a way not specified in the appropriate operator's manual.
- Do not use tools, pins or wires and rigging.
- Be sure safety, warning or marking is complete, legible and in the storage container located on the platform.

Electrocution Hazard

This machine is not electrically insulated and will not provide protection from contact with or proximity to electrical current.

Platform Voltage	Minimum Safe Approach Distance (m)	Ased Contact
120 V to 240 V	1.00	1.00
240 V to 270 V	1.00	1.00
270 V to 300 V	1.00	1.00
300 V to 330 V	1.00	1.00
330 V to 360 V	1.00	1.00
360 V to 390 V	1.00	1.00
390 V to 420 V	1.00	1.00
420 V to 450 V	1.00	1.00
450 V to 480 V	1.00	1.00
480 V to 510 V	1.00	1.00
510 V to 540 V	1.00	1.00
540 V to 570 V	1.00	1.00
570 V to 600 V	1.00	1.00
600 V to 630 V	1.00	1.00
630 V to 660 V	1.00	1.00
660 V to 690 V	1.00	1.00
690 V to 720 V	1.00	1.00
720 V to 750 V	1.00	1.00
750 V to 780 V	1.00	1.00
780 V to 810 V	1.00	1.00
810 V to 840 V	1.00	1.00
840 V to 870 V	1.00	1.00
870 V to 900 V	1.00	1.00
900 V to 930 V	1.00	1.00
930 V to 960 V	1.00	1.00
960 V to 990 V	1.00	1.00
990 V to 1020 V	1.00	1.00
1020 V to 1050 V	1.00	1.00
1050 V to 1080 V	1.00	1.00
1080 V to 1110 V	1.00	1.00
1110 V to 1140 V	1.00	1.00
1140 V to 1170 V	1.00	1.00
1170 V to 1200 V	1.00	1.00
1200 V to 1230 V	1.00	1.00
1230 V to 1260 V	1.00	1.00
1260 V to 1290 V	1.00	1.00
1290 V to 1320 V	1.00	1.00
1320 V to 1350 V	1.00	1.00
1350 V to 1380 V	1.00	1.00
1380 V to 1410 V	1.00	1.00
1410 V to 1440 V	1.00	1.00
1440 V to 1470 V	1.00	1.00
1470 V to 1500 V	1.00	1.00
1500 V to 1530 V	1.00	1.00
1530 V to 1560 V	1.00	1.00
1560 V to 1590 V	1.00	1.00
1590 V to 1620 V	1.00	1.00
1620 V to 1650 V	1.00	1.00
1650 V to 1680 V	1.00	1.00
1680 V to 1710 V	1.00	1.00
1710 V to 1740 V	1.00	1.00
1740 V to 1770 V	1.00	1.00
1770 V to 1800 V	1.00	1.00
1800 V to 1830 V	1.00	1.00
1830 V to 1860 V	1.00	1.00
1860 V to 1890 V	1.00	1.00
1890 V to 1920 V	1.00	1.00
1920 V to 1950 V	1.00	1.00
1950 V to 1980 V	1.00	1.00
1980 V to 2010 V	1.00	1.00
2010 V to 2040 V	1.00	1.00
2040 V to 2070 V	1.00	1.00
2070 V to 2100 V	1.00	1.00
2100 V to 2130 V	1.00	1.00
2130 V to 2160 V	1.00	1.00
2160 V to 2190 V	1.00	1.00
2190 V to 2220 V	1.00	1.00
2220 V to 2250 V	1.00	1.00
2250 V to 2280 V	1.00	1.00
2280 V to 2310 V	1.00	1.00
2310 V to 2340 V	1.00	1.00
2340 V to 2370 V	1.00	1.00
2370 V to 2400 V	1.00	1.00
2400 V to 2430 V	1.00	1.00
2430 V to 2460 V	1.00	1.00
2460 V to 2490 V	1.00	1.00
2490 V to 2520 V	1.00	1.00
2520 V to 2550 V	1.00	1.00
2550 V to 2580 V	1.00	1.00
2580 V to 2610 V	1.00	1.00
2610 V to 2640 V	1.00	1.00
2640 V to 2670 V	1.00	1.00
2670 V to 2700 V	1.00	1.00
2700 V to 2730 V	1.00	1.00
2730 V to 2760 V	1.00	1.00
2760 V to 2790 V	1.00	1.00
2790 V to 2820 V	1.00	1.00
2820 V to 2850 V	1.00	1.00
2850 V to 2880 V	1.00	1.00
2880 V to 2910 V	1.00	1.00
2910 V to 2940 V	1.00	1.00
2940 V to 2970 V	1.00	1.00
2970 V to 3000 V	1.00	1.00

⑥ 09440011



⑦ 09440212



⑧ 09430007



⑨ 09310049



⑩ 09420005

WARNING



⑪ 09310050



⑫ 09410069

WARNING

Crushing Hazard

Lowering the outriggers or tires onto a person's foot can result in serious injury.



Keep clear of outriggers and tires before lowering.

⑬ 09310500

10000 kg
22000 lbs

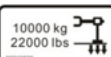

⑭ 09410157





⑮ 09310499

10000 kg
22000 lbs



⑯ 09540001

CE

⑬ 09310500

10000 kg
22000 lbs

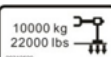

⑰ 09540001

CE

⑱ 09310148

Emergency!

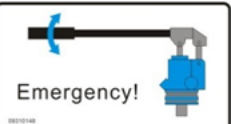

⑲ 09410071

WARNING

Injection Hazard

Escaping fluid under pressure can penetrate skin, causing serious injury.



Relieve pressure before disconnecting hydraulic lines. Keep away from leaks and pin holes. Use a piece of cardboard or paper to search for leaks. Do not use hand. Fluid injected into skin must be surgically removed within a few hours by a doctor familiar with this type of injury or gangrene will result.

⑳ 09410001

DANGER

Explosion/Burn Hazard

Do not operate the machine or charge the batteries in hazardous locations where potentially flammable or explosive gases or particles may be present. Ignition of explosive gases or contact corrosive acid will cause death, burns or blindness.

Keep all open flames and sparks away. Wear personal protective equipment, including face shield, gloves and long sleeve shirt.

Read Manuals
Read all manuals prior to operation.

DO NOT OPERATE equipment if you do not understand the information in the manuals. Consult your supervisor, the owner or the manufacturer.

㉑ 09410003

WARNING

THIS MACHINE MUST NOT BE USED UNTIL IT IS INSPECTED AND OPERATING PROPERLY.

1. Do not operate this machine unless you have been properly trained by a qualified person and authorized to operate this machine. Your training includes reading and understanding the safety, operating and maintenance instructions in manufacturer's manuals, knowing your employers work rules and applicable governmental regulations.
2. Follow the instructions in the Operating Manual and applicable standards for daily, frequent, and annual inspections.
3. Do not replace items (i.e., batteries, wheels, counterweight, etc.) with items of different weight or specification because this will affect stability of machine.
4. Do not modify or change machine without written approval from manufacturer.
5. Operate this machine with extreme caution. STOP all operation if malfunction occurs.
6. Improper use of this machine could cause death or serious injury.

㉒ 09910096

CAUTION

Max. Manual Force



400N

㉓ 09410005

DANGER

Tip-over Hazard

Altering or disabling limit switches can result in machine tip-over. Machine tip-over will result in death or serious injury. Do not alter or disable limit switch(es).



㉔ 09440007

DANGER

Tip-over Hazard

The outriggers must be used when the ground angle is out of machine maximum allowed working angle. Do not set up where it can't be leveled with outriggers.

If tilt alarm sounds, 1. Lower the platform, 2. Move the machine to level surface. Death or serious injury could occur.

DINGLI

DINGLI

15

Decals

JCPT3225RT

26 09640213

JCPT3225RT

27 09440434

28 09410136

24 09330012

29 09310508

30 09310510

35 09330010

31 09310054

HYDRAULIC

32 09310052

33 09310053

34 09420011

36 09310501

Specifications**Model: JCPT2825RT**

Height, working maximum	28m	Airborne noise emissions	<80 dB
Height, platform maximum	26m	Maximum sound level at normal operating workstations (A-weighted)	
Height, stowed maximum Rails up	4.13m	Vibration value does not exceed 2.5m/s ²	
Height, stowed maximum Rails folded	3.19m	Maximum slope rating, Stowed position	40% (22°)
Width	2.50m	Maximum side slope rating, Stowed position	30% (17°)
Length, platform retracted	5.96m	Note: Slope rating is subject to ground conditions and adequate traction.	
Platform dimensions (length × width)	5.48m×2.45m	Maximum working slope	X-2°, Y-3°
Platform extension length	2.1m	Drive speeds	
Maximum load capacity	1000kg	Stowed, maximum	4.0 km/h
Maximum wind speed	12.5m/s	Platform raised, maximum	0.3 km/h
Wheelbase	4.10m	Floor loading information	
Turning radius (outside)	6.0m	Tire load, maximum	8300kg
Turning radius (inside)	3.5m	Outrigger load, maximum	8300kg
Ground clearance	23cm	Tire contact pressure	906kPa
Weight (See Serial Label)		Occupied floor pressure	21.2kPa
Machine weights vary with option configurations		Note: Floor loading information is approximate and does not incorporate different option configurations. It should be used only with adequate safety factors.	
Controls	Proportional	Continuous improvement of our products is a DINGLI policy. Product specifications are subject to change without notice or obligation.	
AC outlet in platform	Standard		
Maximum hydraulic pressure (functions)	250 bar		
Tire size	355/55D625		

Specifications

Model: JCPT3225RT

Height, working maximum	32m	Airborne noise emissions	<80 dB
Height, platform maximum	30m	Maximum sound level at normal operating workstations (A-weighted)	
Height, stowed maximum Rails up	4.13m	Vibration value does not exceed 2.5m/s ²	
Height, stowed maximum Rails folded	3.19m	Maximum slope rating, Stowed position	40% (22°)
Width	2.55m	Maximum side slope rating, Stowed position	30% (17°)
Length, platform retracted	6.73m	Note: Slope rating is subject to ground conditions and adequate traction.	
Platform dimensions (length × width)	6.20m×2.45m	Maximum working slope	X-2°,Y-3°
Platform extension length	2.1m	Drive speeds	
Maximum load capacity	1000kg	Stowed, maximum	4.0 km/h
Maximum wind speed	12.5m/s	Platform raised, maximum	0.3 km/h
Wheelbase	4.86m	Floor loading information	
Turning radius (outside)	6.3m	Tire load, maximum	10000kg
Turning radius (inside)	3.8m	Outrigger load, maximum	10000kg
Ground clearance	20cm	Tire contact pressure	1014.7kPa
Weight (See Serial Label)		Occupied floor pressure	14.1kPa
Machine weights vary with option configurations		Note: Floor loading information is approximate and does not incorporate different option configurations. It should be used only with adequate safety factors.	
Controls	Proportional	Continuous improvement of our products is a DINGLI policy. Product specifications are subject to change without notice or obligation.	
AC outlet in platform	Standard		
Maximum hydraulic pressure (functions)	250 bar		
Tire size	15-625		

Ground Control Panel

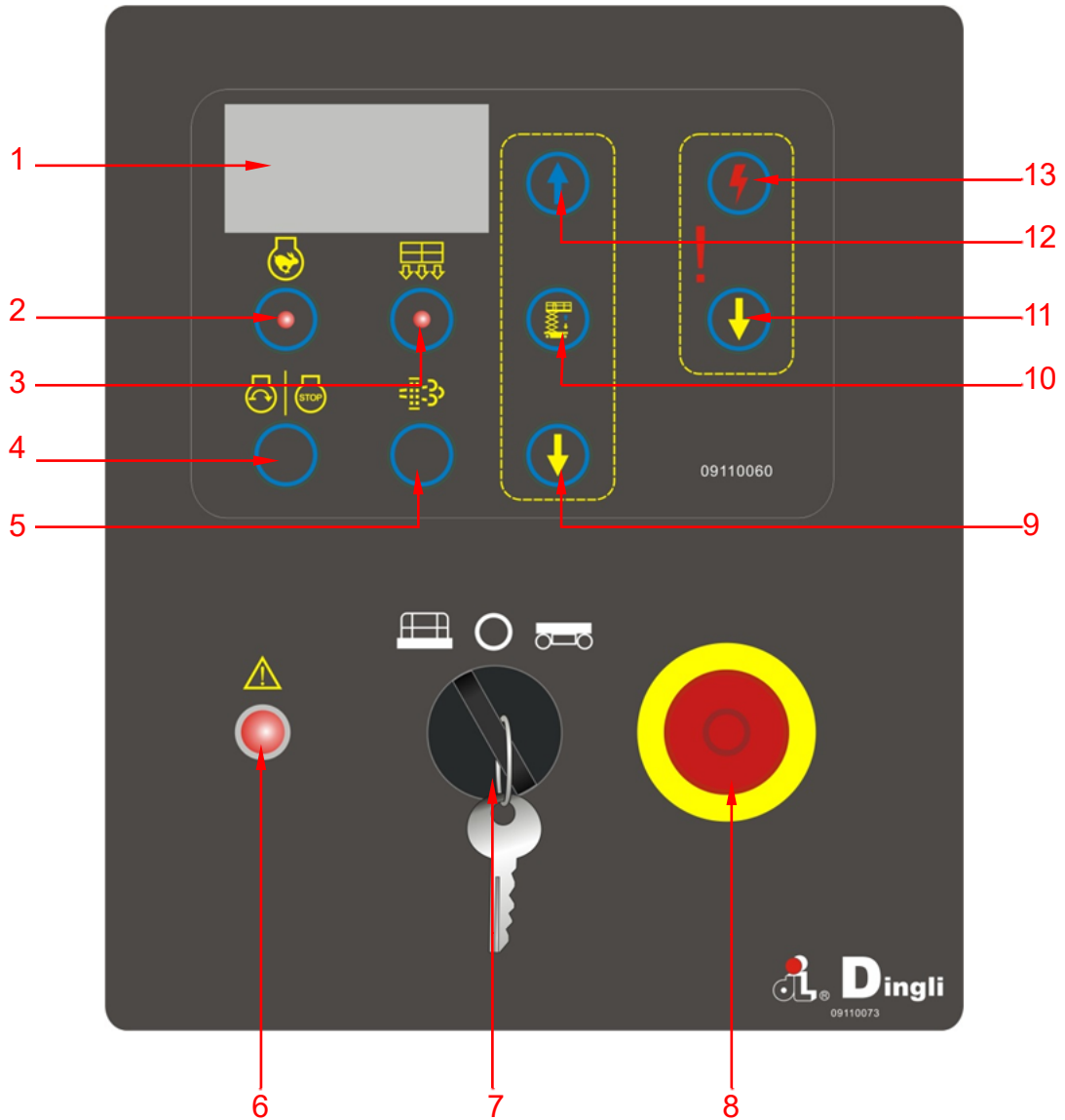

- | | |
|----------------------------------|------------------------------------------|
| 1 Display | 8 Red Emergency Stop button |
| 2 Engine idle select button | 9 Platform down button |
| 3 Overload indicator light | 10 Lift function enable button |
| 4 Engine start/flameout button | 11 Emergency lowering down button |
| 5 Standstill-Regeneration button | 12 Platform up button |
| 6 Engine fault alarm indicator | 13 Emergency lowering down enable button |
| 7 Key switch | |

Controls

Ground Control Panel

- 1 Display
Diagnostic readout
- 2 Engine idle select button
Press this button to select the engine idle setting. Light on indicates high idle is selected. Light off indicates low idle is selected.
- 3 Overload indicator light
Light on indicates when overloaded.
- 4 Engine start/flameout button
Press this button to start/flameout the engine.
- 5 Standstill-Regeneration button
Press and hold this button 2 seconds to perform a regeneration.
- 6 Engine fault alarm indicator
Light on indicates when Engine ECU send fault messages.
- 7 Key switch
Turn the key switch to the platform position and the platform controls will operate.

Turn the key switch to the off position and the machine will be off.

Turn the key switch to the base position and the ground controls will operate.
- 8 Red Emergency Stop button
Push in the red Emergency Stop button to the off position to stop all functions. Pull out the red Emergency Stop button to the on position to operate the machine.
- 9 Platform down button
Press this button and the platform will lower
- 10 Lift function enable button
Press this button to activate the lift function.
- 11 Emergency lowering down button
Press this button and the platform will lower
- 12 Platform up button
Press this button and the platform will lift.
- 13 Emergency lowering down enable button
Press this button to activate the Emergency down function.

Platform Control Panel

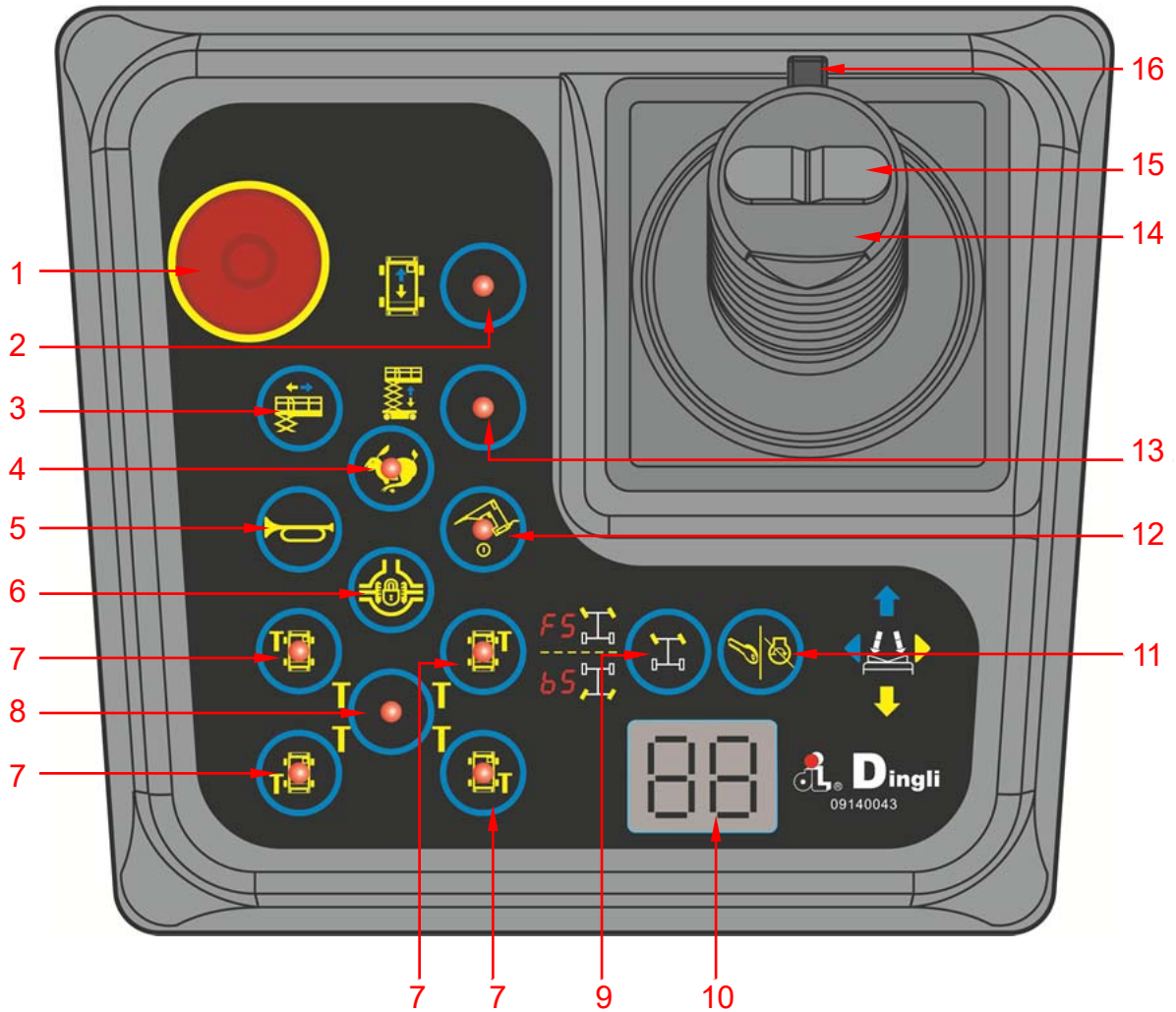

- | | |
|------------------------------------|------------------------------------------|
| 1 Red Emergency Stop button | 9 Steer mode select button |
| 2 Drive function select button | 10 LED readout screen |
| 3 Power platform button | 11 Engine start / flameout button |
| 4 Engine idle select button | 12 Generator select button (if equipped) |
| 5 Horn button | 13 Lift function select button |
| 6 Standby | 14 Proportional control handle |
| 7 Outrigger function enable button | 15 Thumb rocker switch |
| 8 Outrigger auto level button | 16 Function enable switch |

Controls

Platform Control Panel

- 1 Red Emergency Stop button

Push in the red Emergency Stop button to the off position to stop all functions. Pull out the red Emergency Stop button to the on position to operate the machine.
- 2 Drive function select button

Press this button to activate the drive function.
- 3 Power platform button

Press and hold this button to activate the platform extendable / retractable function.
- 4 Engine idle select button

Press this button to select the engine idle setting. Light flickering indicates high idle is selected, Light off indicates low idle is selected.

Press this button and hold on, the engine would be turning in highest speed, no matter a function action is chosen or not; once released, it return back to turn in idle speed.
- 5 Horn button

Press this button and the horn will sound.

Release the button and the horn will stop.
- 6 Standby
- 7 Outrigger function enable button

Press this button to activate the individual outrigger up/down function.
- 8 Outrigger auto level button

Press this button to activate the auto level function.
- 9 Steer mode select button

Press this button to select steer mode: FS mode (Front Steer mode), bS mode (Rear Steer mode).
- 10 LED readout screen

Diagnostic readout and steer mode.
- 11 Engine start / flameout button

Press this button to start/ flameout the engine.
- 12 Generator select button (if equipped)

Press this button to turn the generator on. Indicator light will be on. Press the button again to turn the generator off.
- 13 Lift function select button

Press this button to activate the lift function.
- 14 Proportional control handle

Lift function: Press and hold the function enable switch to enable the lift function on the platform control handle. Move the control handle in the direction indicated by the blue arrow and the platform will raise. Move the control handle in the direction indicated by the yellow arrow and the platform will lower. The descent alarm should sound while the platform is lowering.

Drive function: Press and hold the function enable switch to enable the drive function on the platform control handle. Move the control handle in the direction indicated by the blue arrow on the control panel and the machine will move in the direction that the blue arrow points. Move the control handle in the direction indicated by the yellow arrow on the

control panel and the machine will move in the direction that the yellow arrow points.

Outrigger extendable / retractable function:
Press and hold the function enable switch to enable the Outrigger extend/ retract function on the platform control handle. Move the control handle in the direction indicated by the yellow arrow and the outrigger will extend. Move the control handle in the direction indicated by the blue arrow and the outrigger will retract.

platform extendable / retractable function:
Press and hold the function enable switch to enable the platform extendable / retractable function on the platform control handle. Move the control handle in the direction indicated by the blue arrow and the platform will extend. Move the control handle in the direction indicated by the yellow arrow and the platform will retract.

15 Thumb rocker switch

Press the thumb rocker switch in either direction to activate steer function.

16 Function enable switch

Press and hold the function enable switch to enable the drive/lift function.

Pre-operation Inspection



Do Not Operate Unless:

You learn and practice the principles of safe machine operation contained in this operator's manual.

- 1 Avoid hazardous situations.
- 2 Always perform a pre-operation inspection.**

Know and understand the pre-operation inspection before going on to the next section.

- 3 Inspect the workplace.
- 4 Always perform function tests prior to use.
- 5 Only use the machine as it was intended.

Fundamentals

It is the responsibility of the operator to perform a pre-operation inspection and routine maintenance.

The pre-operation inspection is a visual inspection performed by the operator prior to each work shift. The inspection is designed to discover if anything is apparently wrong with a machine before the operator performs the function tests.

The pre-operation inspection also serves to determine if routine maintenance procedures are required. Only routine maintenance items specified in this manual may be performed by the operator.

Refer to the list on the next page and check each of the items.

If damage or any unauthorized variation from factory delivered condition is discovered, the machine must be tagged and removed from service.

Repairs to the machine may only be made by a qualified service technician, according to the manufacturer's specifications. After repairs are completed, the operator must perform a pre-operation inspection again before going on to the function tests.

Scheduled maintenance inspections shall be performed by qualified service technicians, according to the manufacturer's specifications and the requirements listed in this manual.

Pre-operation Inspection

Pre-operation Inspection

- Be sure that the operator's manual are complete, legible and in the storage container located in the platform.
- Be sure that all decals are legible and in place. See Decals section.
- Check for engine oil leaks and proper oil level. Add oil if needed. See Maintenance section.
- Check for hydraulic oil leaks and proper oil level. Add oil if needed. See Maintenance section.
- Check for engine coolant leaks and proper level of coolant. Add coolant if needed. See Maintenance section.
- Check for battery fluid leaks and proper fluid level. Add distilled water if needed. See Maintenance section.
- Beacon (if equipped)
- Safety arm
- Platform extension(s)
- Scissor pins and retaining fasteners
- Platform control joystick
- Oscillate Axle
- Differential lock
- Outrigger housings and footpads

Check entire machine for:

- Cracks in welds or structural components
- Dents or damage to machine
- Be sure that all structural and other critical components are present and all associated fasteners and pins are in place and properly tightened

Check the following components or areas for damage, improperly installed or missing parts and unauthorized modifications:

- Electrical components, wiring and electrical cables
- Hydraulic hoses, fittings, cylinders and manifolds
- Fuel and hydraulic tanks
- Drive motors
- Wear pads
- Tires and wheels
- Engine and related components
- Limit switches, alarms and horn
- Nuts, bolts and other fasteners
- Platform overload components
- Platform entry gate

Note: If the platform must be raised to inspect the machine, make sure the safety arm is in place. See Operating Instructions section.

Workplace Inspection



Do Not Operate Unless:

You learn and practice the principles of safe machine operation contained in this operator's manual.

- 1 Avoid hazardous situations.
- 2 Always perform a pre-operation inspection.
- 3 Inspect the workplace.**

Know and understand the workplace inspection before going on to the next section.

- 4 Always perform function tests prior to use.
- 5 Only use the machine as it was intended.

Fundamentals

The workplace inspection helps the operator determine if the workplace is suitable for safe machine operation. It should be performed by the operator prior to moving the machine to the workplace.

It is the operator's responsibility to read and remember the workplace hazards, then watch for and avoid them while moving, setting up and operating the machine.

Workplace Inspection

Be aware of and avoid the following hazardous situations:

- Drop-offs or holes
- Bumps, floor obstructions or debris
- Sloped surfaces
- Unstable or slippery surfaces
- Overhead obstructions and high voltage conductors
- Hazardous locations
- Inadequate surface support to withstand all load forces imposed by the machine
- Wind and weather conditions
- The presence of unauthorized personnel
- Other possible unsafe conditions

Function Tests



Do Not Operate Unless:

- You learn and practice the principles of safe machine operation contained in this operator's manual.
- 1 Avoid hazardous situations.
- 2 Always perform a pre-operation inspection.
- 3 Inspect the workplace.
- 4 **Always perform function tests prior to use.**

Know and understand the function tests before going on to the next section.

- 5 Only use the machine as it was intended.

Fundamentals

The function tests are designed to discover any malfunctions before the machine is put into service.

The operator must follow the step-by-step instructions to test all machine functions.

A malfunctioning machine must never be used. If malfunctions are discovered, the machine must be tagged and removed from service. Repairs to the machine may only be made by a qualified service technician, according to the manufacturer's specifications.

After repairs are completed, the operator must perform a pre-operation inspection and function tests again before putting the machine into service.

Function Tests

- 1 Select a test area that is firm, level and free of obstruction.

At the Ground Controls

- 2 Pull out the platform and ground red Emergency Stop button to the on position.
 - 3 Turn the key switch to ground control.
 - 4 Observe the display on the ground controls.
- ⊙ Result: The display readout will come on and display SYSTEM READY.
- 5 Start the engine. See Operating Instructions section.

Test Emergency Stop

- 6 Push in the ground red Emergency Stop button to the off position.
- ⊙ Result: The engine should turn off and no functions should operate.
- 7 Pull out the red Emergency Stop button to the on position and restart the engine.

Test Up/Down Functions and Function Enable

A buzzer with different sound frequency is controlled in central system. The descent alarm sounds at 60 beeps per minute. The descent delay alarm sounds at 120 beeps per minute. The alarm that goes off when the machine is not level sounds at 180 beeps per minute. An optional automotive-style horn is also available.

- 8 Do not press the lift function enable button. Press and hold the platform up/down button.
- ⊙ Result: No function should operate.
- 9 Press and hold the lift function enable

button. Press and hold the platform up button.

- ⊙ Result: The platform should rise.

- 10 Press and hold the lift function enable button. Press and hold the platform down button.

- ⊙ Result: The platform should lower the descent alarm should sound while the platform is lowering. The platform stop at the height is approximately 4.5 m from the ground. The descent delay alarm will sound.

Note: Be sure the area below the platform is clear of personnel and obstructions before continuing.

- 11 Press and hold the lift function enable button. Press and hold the platform down button.

- ⊙ Result: The platform should lower to end. The descent delay alarm should sound while the platform is lowering.

Test the Auxiliary Lowering

- 12 Activate the up function and raise the platform approximately 60 cm.
- 13 Press the engine start/ flameout button to engine off.
- 14 Press and hold the lift function enable button. Press and hold the platform down button.

- ⊙ Result: The platform should lower.

Test the Emergency Lowering

- 15 Activate the up function and raise the platform approximately 60 cm.
- 16 Press the engine start/ flameout button to engine off.
- 17 Press and hold the emergency lowering

Function Tests

down enable button. Press and hold the emergency lowering down button.

- ⊙ Result: The platform should lower.

18 Turn the key switch to platform control and restart the engine.

At the Platform Controls

Test Emergency Stop

19 Push in the platform red Emergency Stop button to the off position.

- ⊙ Result: No functions should operate.

20 Pull the red Emergency Stop button out to the on position.

- ⊙ Result: The LED indicator light should come on.

Test the Horn

21 Push the horn button.

- ⊙ Result: The horn should sound.

Test Up/Down Functions and Function Enable

22 Start the engine.

23 Do not hold the function enable switch on the control handle.

24 Slowly move the control handle in the direction indicated by the blue arrow, then in the direction indicated by the yellow arrow.

- ⊙ Result: No functions should operate.

25 Press the lift function select button.

26 Press and hold the function enable switch on the control handle.

27 Slowly move the control handle in the direction indicated by the blue arrow.

- ⊙ Result: The platform should raise.

28 Release the control handle.

- ⊙ Result: The platform should stop raising.

29 Press and hold the function enable switch. Slowly move the control handle in the direction indicated by the yellow arrow.

- ⊙ Result: The platform should lower. The descent alarm should sound while the platform is lowering.

Test the Steering

Note: When performing the steer and drive function test, stand in the platform facing the steer end of the machine.

30 Press the drive function select button. The indicator light should turn on.

31 Push the steer mode select button for steer FS mode (Front Steer mode).

32 Press and hold the function enable switch on the proportional control handle. Depress the thumb rocker switch on top of the proportional control handle in the direction identified by the blue triangle on the control panel.

- ⊙ Result: The front wheels should turn in the direction that the blue triangle points on the control panel.

33 Press and hold the function enable switch on the proportional control handle. Depress the thumb rocker switch in the direction identified by the yellow triangle on the control panel.

- ⊙ Result: The front wheels should turn in the direction that the yellow triangle points on the control panel.

34 Press the drive function select button. The indicator light should turn on.

Function Tests

- 35 Push the steer mode select button for steer FS mode (Rear Steer mode).
- 36 Press and hold the function enable switch on the proportional control handle. Depress the thumb rocker switch on top of the proportional control handle in the direction identified by the blue triangle on the control panel.
- ⊙ Result: The rear wheels should turn in the direction that the yellow triangle points on the control panel.
- 37 Press and hold the function enable switch on the proportional control handle. Depress the thumb rocker switch in the direction identified by the yellow triangle on the control panel.
- ⊙ Result: The rear wheels should turn in the direction that the blue triangle points on the control panel.

Test Drive and Braking

- 38 Press and hold the function enable switch on the proportional control handle.
- 39 Slowly move the proportional control handle in the direction indicated by the blue arrow on the control panel until the machine begins to move, then return the proportional control handle to the center position.
- ⊙ Result: The machine should move in the direction that the blue arrow points on the control panel, then come to an abrupt stop.
- 40 Press and hold the function enable switch on the proportional control handle.
- 41 Slowly move the proportional control handle in the direction indicated by the yellow arrow on the control panel until the machine begins to move, then return the proportional handle to the center position.

- ⊙ Result: The machine should move in the direction that the yellow arrow points on the control panel, then come to an abrupt stop.

Note: The brakes must be able to hold the machine on any slope it is able to climb.

Test Limited Drive Speed

- 42 Press the lift function select button. Raise the platform approximately 4.5 m from the ground.
- 43 Press the drive function select button.
- 44 Press and hold the function enable switch on the proportional control handle slowly move the proportional control handle to the full drive position.
- ⊙ Result: The maximum achievable drive speed with the platform raised should not exceed 8.3cm/s.
- ⊘ Result: If the drive speed with the platform raised exceeds 8.3cm/s, immediately tag and remove the machine from service.

Test the Tilt Sensor Operation

Note: Perform this test from the ground with the platform controller. Do not stand in the platform.

- 45 Fully lower the platform.
- 46 Drive both wheels on one side onto an 12cm block.
- 47 Raise the platform approximately 4.5 m from the ground.
- ⊙ Result: The platform should stop and the tilt alarm will sound at 180 beeps per minute. The platform controls LED readout should display LL.
- 48 Press the drive function select button.
- 49 Press and hold the function enable switch on the control handle.

Function Tests

50 Move the proportional control handle in the direction indicated by the blue arrow, then move the proportional control handle in the direction indicated by the yellow arrow.

- ⊙ Result: The drive function should not work in either direction.

51 Press the lift function enable button.

52 Lower the platform and drive the machine off the block.

Test the Outrigger System

53 Push and hold the auto level button.

54 Press and hold the function enable switch. Activate the proportional control handle in the direction indicated by the yellow arrow.

- ⊙ Result: The outriggers will extend and level the machine. A beep will sound when the machine is level.

55 Push and hold the auto level button.

56 Press and hold the function enable switch. Activate the proportional control handle in the direction indicated by the blue arrow.

- ⊙ Result: The outriggers should retract and return to the stowed position. A beep will sound when the machine is in the stowed position.

Test Auxiliary Lowering

57 Push and hold the function enable switch and raise the platform approximately 60 cm.

58 Press the engine start/ flameout button to engine off.

59 Push and hold the function enable switch. Activate the control handle in the direction indicated by the yellow arrow.

- ⊙ Result: The platform should lower.

Test Platform extendable / retractable Functions

60 Push and hold the Power platform button. Press and hold the function enable switch. Activate the proportional control handle in the direction indicated by the blue arrow

- ⊙ Result: The platform should extend.

61 Push and hold the Power platform button. Press and hold the function enable switch. Activate the proportional control handle in the direction indicated by the yellow arrow.

- ⊙ Result: The platform should retract.

Operating Instructions



Do Not Operate Unless:

You learn and practice the principles of safe machine operation contained in this operator's manual.

- 1 Avoid hazardous situations.
- 2 Always perform a pre-operation inspection.
- 3 Inspect the workplace.
- 4 Always perform function tests prior to use.
- 5 **Only use the machine as it was intended.**

Fundamentals

This machine is a self-propelled hydraulic lift equipped with a work platform on the scissor mechanism. Vibrations emitted by these machines are not hazardous to an operator in the work platform. The machine can be used to position personnel with their tools and supplies at position above ground level and can be used to reach work areas located above and over machinery or equipment.

A full and detailed implementation of EN ISO 13849-1/2 is correctly applied on our MEWP design. SISTEMA, a software tool for PL Calculation Tool, is also used to perform some relatively straightforward calculations on subsystem to determine the overall PL of the system.

Reliability data, diagnostic coverage [DC], the system architecture [Category], common cause failure and, where relevant, requirements for software are used to assess the PL to comply with PLr of SRP/CS in EN 280.

The Operating Instructions section provides instructions for each aspect of machine operation. It is the operator's responsibility to follow all the safety rules and instructions in the operator's manual.

Using the machine for anything other than lifting personnel, along with their tools and materials, to an aerial work site is unsafe and dangerous.

Only trained and authorized personnel should be permitted to operate a machine. If more than one operator is expected to use a machine at different times in the same work shift, they must all be qualified operators and are all expected to follow all safety rules and instructions in the operator's manual. That means every new operator should perform a pre-operation inspection, function tests, and a workplace inspection before using the machine.

Operating Instructions

Emergency Stop

Push in the red Emergency Stop button to the off position at the ground controls or the platform controls to stop all machine functions and turn the engine off.

Repair any function that operates when either red Emergency Stop button is pushed in.

Starting the Engine

- 1 At the ground controls, turn the key switch to the desired position.
- 2 Be sure both ground and platform control red Emergency Stop buttons are in the on position.
- 3 Press the engine start/flameout button.

When the temperature is too low, the engine will be preheated automatically.

If the engine fails to start after 15 seconds of cranking, determine the cause and repair any malfunction. Wait 60 seconds before trying to start again.

In cold conditions, -6°C and below, warm the engine for 5 minutes before operating to prevent hydraulic system damage.

In extreme cold conditions, -18°C and below, machines should be equipped with optional cold start kits. Attempting to start the engine when temperatures are below -18°C may require the use of a booster battery.

Operation from Ground

- 1 Turn the key switch to ground control.
- 2 Pull out the platform and ground red Emergency Stop button to the on position.
- 3 Start the engine.

To Position Platform

- 1 Press the lift function enable button.
- 2 Press the platform up/down button to activate the up function or the down function.

Drive and steer functions are not available from the ground controls.

Engine Idle Select

Select the engine idle (rpm) by pressing the engine idle select button.

There are two settings for engine idle:

- Indicator light off: low idle
- Indicator light on: high idle

Operation from Platform

- 1 Turn the key switch to platform control.
- 2 Pull out the platform and ground red Emergency Stop button to the on position.
- 3 Start the engine.

To Position Platform

- 1 Press the lift function select button.
- 2 Press and hold the function enable switch on the control handle.
- 3 Activate the proportional control handle in the desired direction.

To Steer

- 1 Press the drive function select button.
- 2 Press and hold the function enable switch on the control handle.
- 3 Push the steer mode select button for steer mode (FS. bS)
- 4 Turn the steer wheels with the thumb rocker switch located on the top of the control handle.

Operating Instructions

To Drive

- 1 Press the drive function select button.
- 2 Press and hold the function enable switch on the control handle.
- 3 Increase speed: Slowly move the control handle off center.

Decrease speed: Slowly move the control handle toward center.

Stop: Return the control handle to center or release the function enable switch.

Use the direction arrows on the platform controls to identify the direction the machine will travel.

Machine travel speed is restricted when the platform is raised.

Drive speed select

The drive controls can operate in two different drive speed modes. When the engine idle select button light is off, slow drive speed mode is active. When the engine idle select button light is on, fast drive speed mode is active.

Driving on a slope

Determine the slope and side slope ratings for the machine and determine the slope grade.

Maximum slope rating, stowed position 40%,
Maximum side slope rating, stowed position 40%

Note: Slope rating is subject to ground conditions and adequate traction.

Press the drive speed select button to the fast drive speed mode.

To determine the slope grade

Measure the slope with a digital inclinometer or use the following procedure.

You will need:

Carpenter's level

Straight piece of wood, at least 1 m long
tape measure

Lay the piece of wood on the slope

At the downhill end, lay the level on the top edge of the piece of wood and lift the end until the piece of wood is level.

While holding the piece of wood level, measure the distance from the bottom of the piece of wood to the ground.

Divide the tape measure distance (rise) by the length of the piece of wood (run) and multiply by 100.

Example:

Run = 3.6 m

Rise = 0.3 m

$0.3 \text{ m} \div 3.6 \text{ m} = 0.083 \times 100 = 8.3\%$



If the slope exceeds the maximum slope or side slope rating, the machine must be winched or transported up or down the slope. See Transport and Lifting section.

To Extend and Retract Platform

- 1 Push and hold the Power platform button. Press and hold the function enable switch. Activate the proportional control handle in the direction indicated by the blue arrow
- 2 Push and hold the Power platform button. Press and hold the function enable switch. Activate the proportional control handle in the direction indicated by the yellow arrow.

Operating Instructions

Operation from Ground with Controller

Maintain safe distances between operator, machine and fixed objects.

Be aware of the direction the machine will travel when using the controller.

Outrigger Operation

- 1 Position the machine below the desired work area.

Note: The engine must be running for the outriggers to operate.

- 2 Push and hold the outrigger auto level button.
- 3 Press and hold the function enable switch. Activate the proportional control handle in the direction indicated by the yellow arrow. The outriggers will extend and level the machine. A beep will sound when the machine is level.

The indicator light on the lift function enable button will turn on when one but not all outriggers are down. All drive and lift functions are disabled.

The indicator lights on the lift function enable button and on the individual outrigger buttons will turn off when all the outriggers are in firm contact with the ground.

The drive function is disabled while the outriggers are down.

To control individual outrigger

- 1 Push and hold one or more outrigger function enable buttons.
- 2 Press and hold the function enable switch. Activate the proportional control handle in the direction indicated by the yellow arrow.

The outriggers will extend and level the machine.

⚠ WARNING Cannot use the outrigger directly on uneven surface, soft ground, pit edges and slopes greater ground, To avoid the risk of machine tipping, casualties and equipment damage. If it must be used on the above ground, be sure to use wood or steel pad adapt to the ground, and make sure it is firm.

Emergency Lowering

- 1 Turn the key switch to ground control.
- 2 Press and hold the emergency lowering down enable button.
- 3 Press and hold the emergency lowering down button.

Engine DPF Regeneration

The DPF system is a closed soot filter system that accumulates the soot load during operation time of the machine. The filter regeneration is a continuous process (CRT) starting as soon as the necessary conditions at the inlet of the system are reached. These conditions are mainly exhaust temperatures and NOx/Soot-ratio.

The filter load is permanently monitored.

If the regeneration-process is not possible for any reason the system triggers additional actions to start the regeneration.

An operator reaction is required only if these actions are not successful.

0 Normal Operation, "Level 0"

Under average operating conditions the filter load stays in within an expected range and no

Operating Instructions

further action is needed.

1 Heat Mode 1, "Level 1"

Active when: relative Soot load > 62%:

If the operating conditions of the machine do not allow a successful continuous regeneration process, the filter load can exceed the expected range. This could happen in applications with extremely low load profiles or at permanent short time operations.

In this case the engine enters Heat Mode 1 and engine internal actions (example: using intake throttle flap or exhaust flap) are released in order to improve the regeneration conditions.

Operator actions are not needed at this point.

2 Heat Mode 2, "Level 2"

Active when: relative Soot load > 78%:

If heat mode 1 is not sufficient to allow a reduction of the soot load, the filter load continues rising and stronger engine internal actions become necessary to improve the regeneration conditions.

Influence on fuel consumption and engine dynamic response is higher than in heat mode 1.

Operator actions are not needed at this point.

3 Standstill Required, "Level 3"

Active when: relative Soot load > 100%:

If the heat mode is not sufficient to allow a reduction of the soot load, the filter load continues rising and finally a standstill-regeneration is requested.

The Ground control Display would display this

symbol  (DPF Particulate Filter Restricted), Operator need to assist with the following operations.

1) Drive machine to a flat and well-ventilated position.

2) Turn the key switch to ground control.

3) Press and hold Standstill-Regeneration button 2 seconds.

After completing the above operation, the engine will enter Standstill-Regeneration mode. The standstill is the last option to regenerate a filter if all other attempts to clean the filter failed.

During an active standstill high exhaust gas temperatures can occur.

The engine speed will be changed to a predefined value and cannot be influenced by the operator.

In case of often standstills, system verification is necessary. Furthermore due to extreme engine settings the engine oil quality is influenced by standstill. After a certain number of standstills an oil exchange is to be done.

The standstill is a special engine operation mode and it is not allowed to use the machine and/or increase the load higher than basic load during the active standstill regeneration!

4 Standstill Required, "Level 4"

Active when: relative Soot load > 109%:

If the operator ignores the standstill request, engine protection functionalities are activated (low engine RPM), and cut of lifting function.

5 Service Required, "Level 5"

Active when: relative Soot load > 125%:

The soot load is so high that a service-regeneration via Service Tool (SERDIA) has to be performed. That implies that a service technician need to be on location and the regeneration cannot be

Operating Instructions

performed by the operator.

6 Replace DPF Required, "Level 6"

Active when: relative Soot load > 156%:

Soot load has reached a critical level where safe regeneration in machine no longer can be ensured. The DPF has to be replaced before continued operation is allowed.

How to Fold Down the Guardrails

The platform railing system consists of three fold down rail section for the extension deck and three sections for the main deck. All sections are held in place by four latches.

- 1 Fully lower the platform and retract the platform extension.
- 2 Remove the platform controls.

Opening the latches in the corners the rails have to be folded in correct order of the numbering.

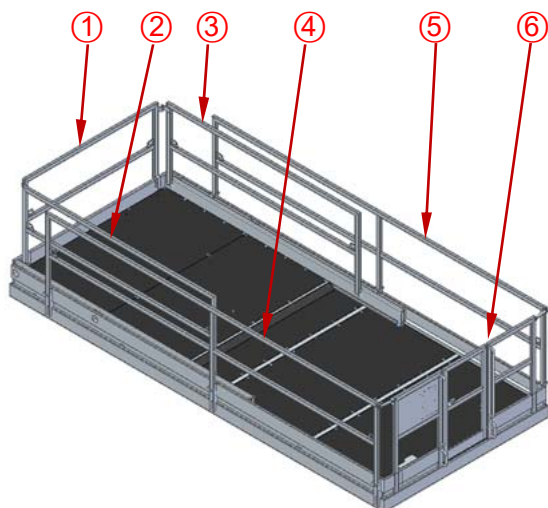
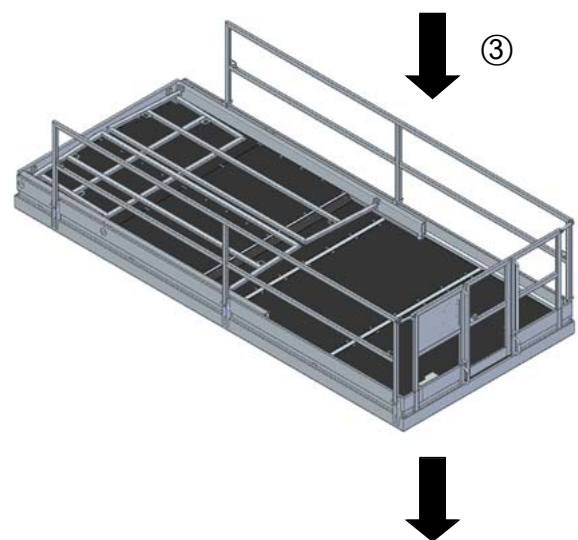
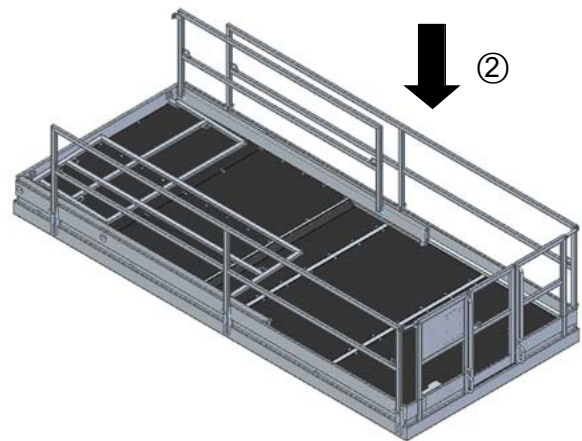
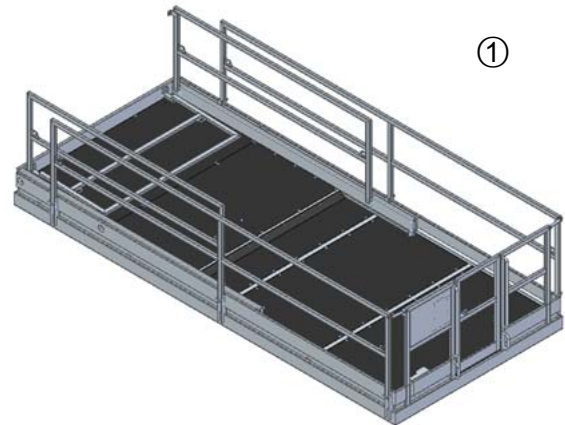

Operating Instructions

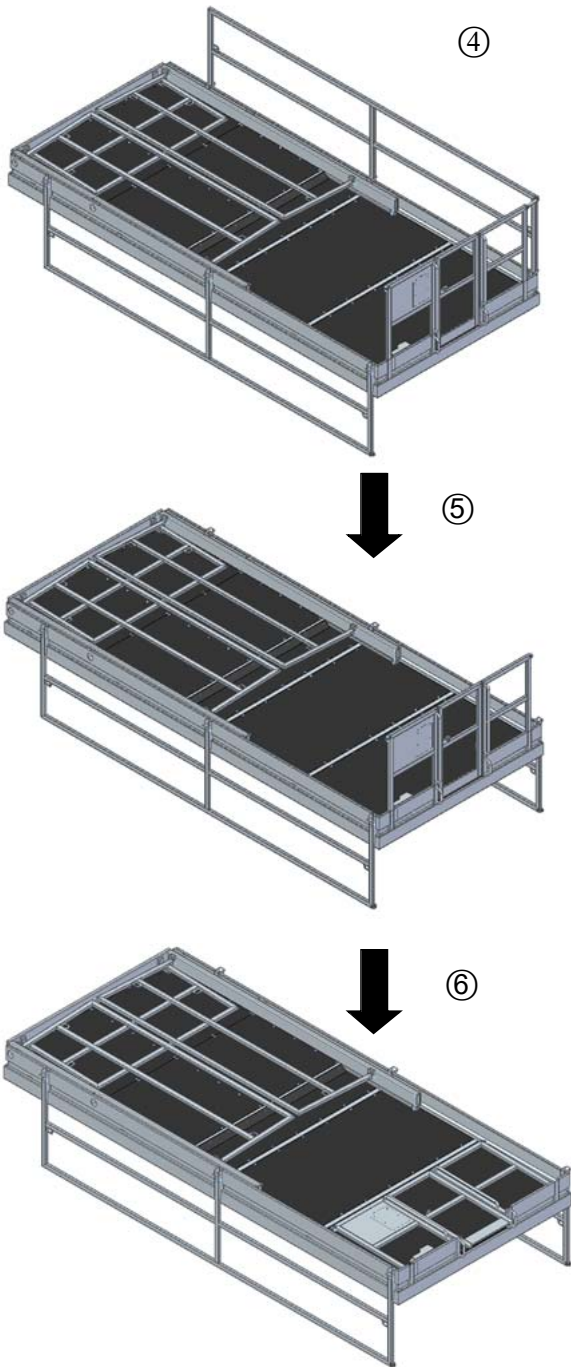

How to Raise the Guardrails

Follow the fold down instructions but in reverse order.

Emergency operating with hand pump

Emergency Lowering

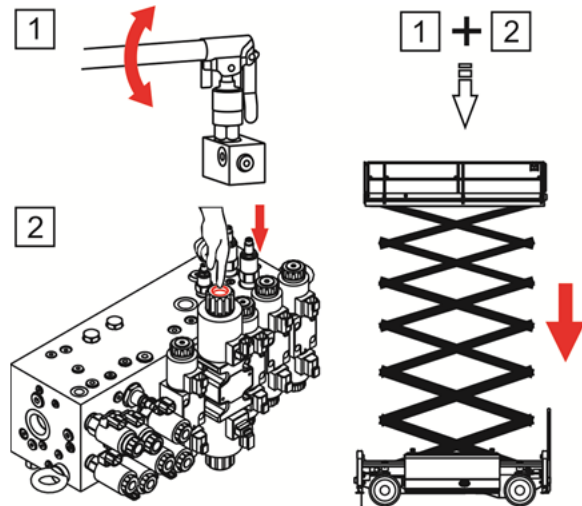

- 1 Unplug the lever and put it into the hand pump (1).
- 2 Press and hold the button (2).
- 3 Operate the hand pump with the lever, the platform should lower.

Retracting outriggers

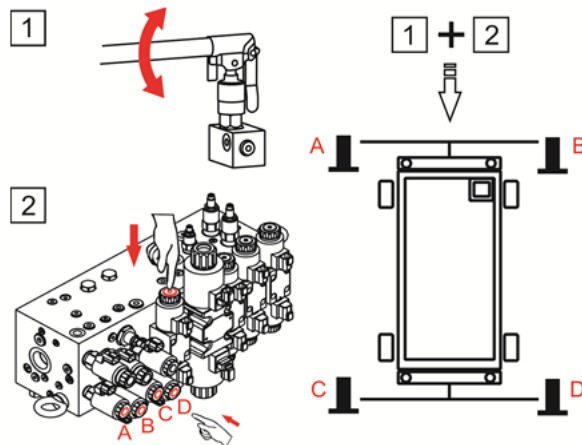

- 1 Unplug the lever and put it into the hand pump (1)
- 2 Press and hold the button (4).
- 3 Choose the outrigger which needs to

Operating Instructions

retract, Press the corresponding knob in the direction of the arrow.

- 4 Operate the hand pump with the lever, the outrigger emergency retract

Retracting Platform

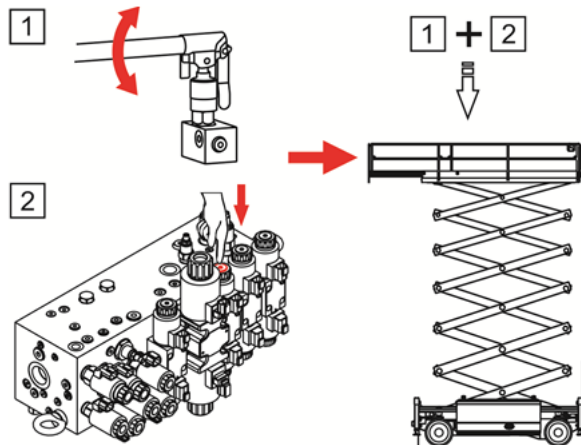

- 1 Unplug the lever and put it into the hand pump (1).
- 2 Press and hold the button (3)
- 3 Operate the hand pump with the lever, the platform should retract.
- 4 **⚠ WARNING** Do not emergency lower the platform and retract outriggers simultaneity; Reset the knob after all operations completed.
- 5 **⚠ WARNING** Emergency actuation of outriggers only in normal position danger of tipping!

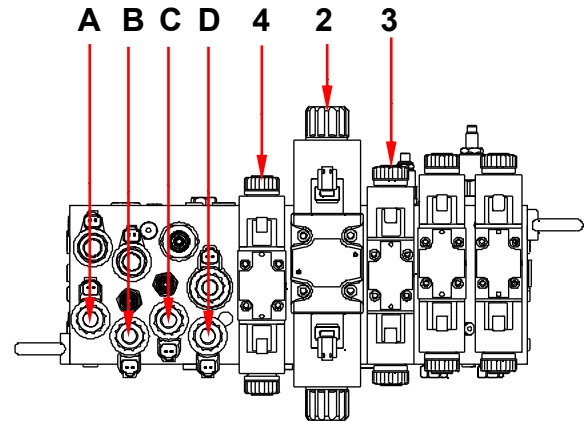
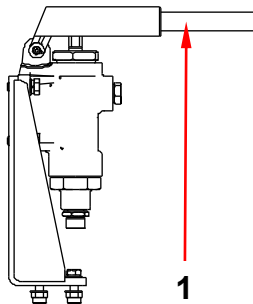

After Each Use

- 1 Select a safe parking location - firm level surface, clear of obstructions and traffic.
- 2 Lower the platform.
- 3 Turn the key switch to the off position and remove the key to secure from unauthorized use.
- 4 Push in the red Emergency Stop buttons to "off" position.
- 5 Push in the main power switch to "off" position.
- 6 Chock the wheels.

Transport and Lifting Instructions



Observe and Obey:

- ✓ Common sense and planning must be applied to control the movement of the machine when lifting it with a crane or forklift.
- ✓ Only qualified aerial lift operators should move the machine on or off the truck.
- ✓ The transport vehicle must be parked on a level surface.
- ✓ The transport vehicle must be secured to prevent rolling while the machine is being loaded.
- ✓ Be sure the vehicle capacity, loading surfaces and chains or straps are sufficient to withstand the machine weight. See the serial label for the machine weight.
- ✓ The machine must be on a level surface or secured before releasing the brakes.
- ✓ Do not allow the rails to fall when the snap pins are removed. Maintain a firm grasp on the rails when the rails are lowered.
- ✓ Do not drive the machine on a slope that exceeds the slope or side slope rating. See *Driving on a Slope* in the *Operating Instructions* section.
- ✓ If the slope of the transport vehicle bed exceeds the maximum slope rating, the machine must be loaded and unloaded using a winch as described.

Free-wheel Configuration for Winching

Chock the wheels to prevent the machine from rolling.

4WD models: Release the wheel brakes by turning over all four torque hub disconnect caps (see below).

Be sure the winch line is properly secured to the drive chassis tie points and the path is clear of all obstructions.

Reverse the procedures described to re-engage the brakes.

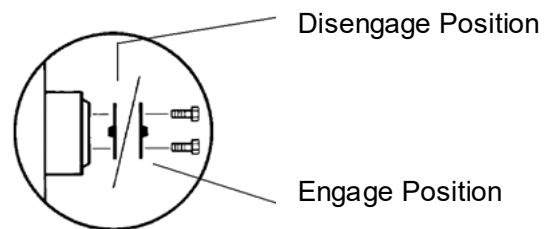

Transport and Lifting Instructions

Securing to Truck or Trailer for Transit

Always chock the machine wheels in preparation for transport.

Retract and secure the extension deck(s).

Use the tie-down points on the chassis for anchoring down to the transport surface.

Use a minimum of four chains or straps.

Use chains or straps of ample load capacity.

Turn the key switch to the off position and remove the key before transporting.

Inspect the entire machine for loose or unsecured items.

If the railings have been folded down, secure them with straps before transporting.

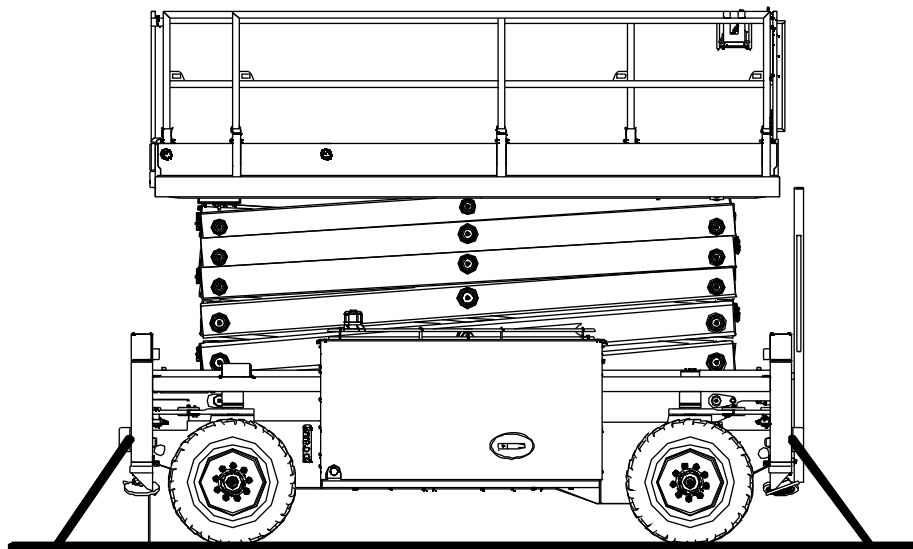
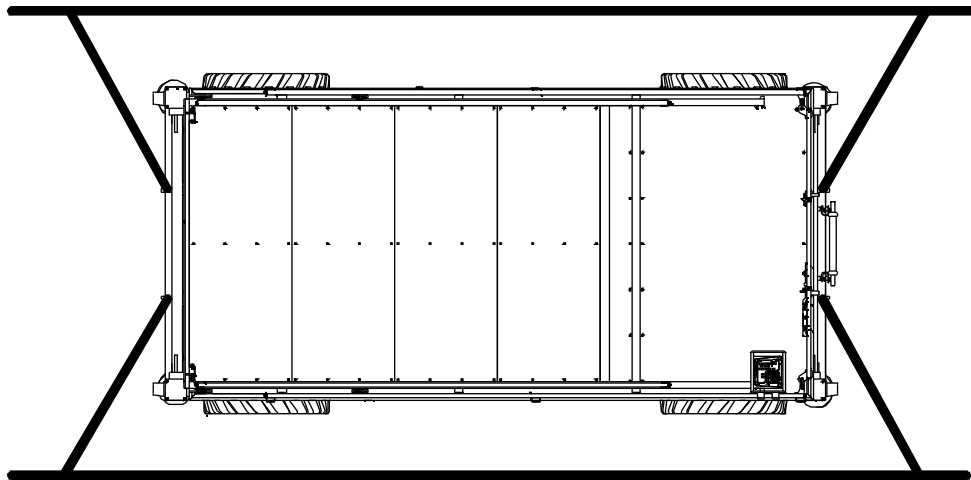

Transport and Lifting Instructions



Observe and Obey:

- Only qualified riggers should rig and lift the machine.
- Be sure the crane capacity, loading surfaces and straps or lines are sufficient to withstand the machine weight. See the serial plate for the machine weight.

Determine the center of gravity of your machine using the table and the picture on this page.

Attach the rigging only to the designated lifting points on the machine. There are two lifting points on each end of the machine.

Adjust the rigging to prevent damage to the machine and to keep the machine level.

Lifting Instructions

Fully lower the platform. Be sure the extension decks, controls and covers are secure. Remove all loose items on the machine.

Center of gravity	X Axis	Y Axis
JCPT2825RT	2.3m	1.0m
JCPT3225RT	2.7m	1.0m

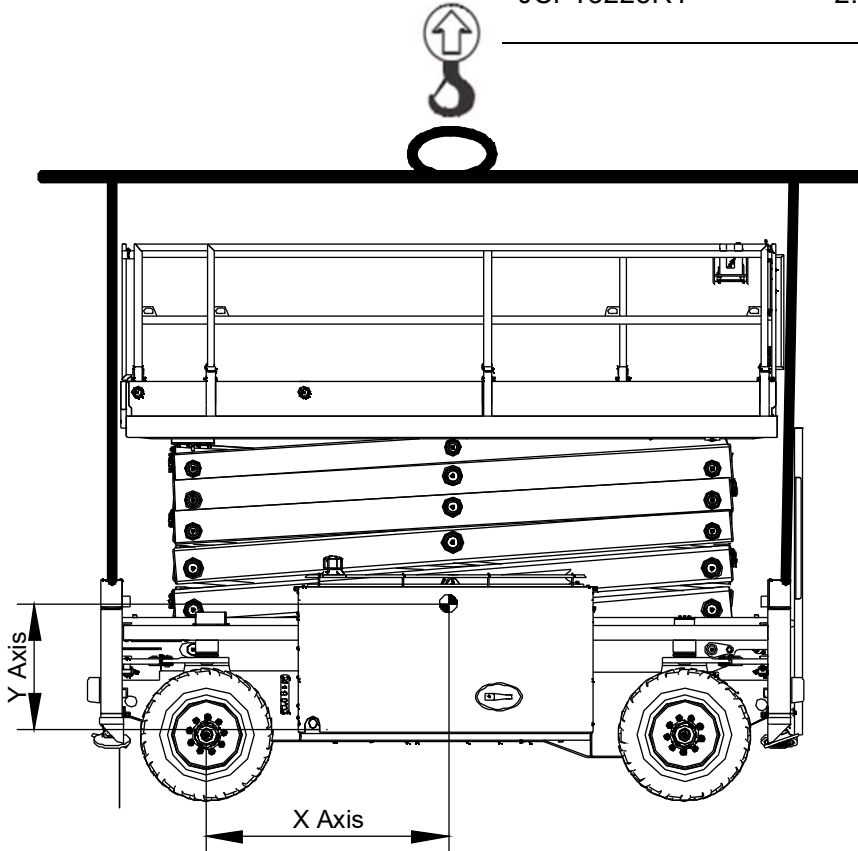

Maintenance



Observe and Obey:

- ✓ Only routine maintenance items specified in this manual shall be performed by the operator.
- ✓ Scheduled maintenance inspections shall be completed by qualified service technicians, according to the manufacturer's specifications and the requirements specified in this manual.

Maintenance Symbols Legend

NOTICE The following symbols have been used in this manual to help communicate the intent of the instructions. When one or more of the symbols appear at the beginning of a maintenance procedure, it conveys the meaning below.



Indicates that tools will be required to perform this procedure.



Indicates that new parts will be required to perform this procedure.



Indicates that dealer service will be required to perform this procedure.

Pre-delivery Preparation Report

The pre-delivery preparation report contains checklists for each type of scheduled inspection.

Make copies of the Pre-delivery Preparation report to use for each inspection. Store completed forms as required.

Maintenance Schedule

There are five types of maintenance inspections that must be performed according to a schedule—daily, quarterly, semi-annually, annually, and two year. The Scheduled Maintenance Procedures Section and the Maintenance Inspection Report have been divided into five subsections—A, B, C, D, and E. Use the following chart to determine which group(s) of procedures are required to perform a scheduled inspection.

Inspection	Checklist
Daily or every 8 hours	A
Quarterly or every 250 hours	A+B
Semi-annually or every 500 hours	A+B+C
Annually or every 1000 hours	A+B+C+D
Two year or every 2000 hours	A+B+C+D+E

Maintenance Inspection Report

The maintenance inspection report contains checklists for each type of scheduled inspection.

Make copies of the Maintenance Inspection Report to use for each inspection. Maintain completed forms for a minimum of 4 years or in compliance with your employer, jobsite and governmental regulations and requirements.

Maintenance

Pre-delivery Preparation Report

Fundamentals

It is the responsibility of the dealer to perform the Pre-delivery Preparation.

The Pre-delivery Preparation is performed prior to each delivery. The inspection is designed to discover if anything is apparently wrong with a machine before it is put into service.

A damaged or modified machine must never be used. If damage or any variation from factory delivered condition is discovered, the machine must be tagged and removed from service.

Repairs to the machine may only be made by a qualified service technician, according to the manufacturer's specifications.

Scheduled maintenance inspections shall be performed by qualified service technicians, according to the manufacturer's specifications and the requirements listed in this manual.

Instructions

Use the operator's manual on your machine.

The Pre-delivery Preparation consists of completing the Pre-operation Inspection, the Maintenance items and the Function Tests.

Use this form to record the results. Place a check in the appropriate box after each part is completed. Follow the instructions in the operator's manual.

If any inspection receives an N, remove the machine from service, repair and re-inspect it. After repair, place a check in the R box.

Legend

Y = yes, completed

N = no, unable to complete

R = repaired

Comments

Pre-Delivery Preparation	Y	N	R
Pre-operation inspection completed			
Maintenance items completed			
Function tests completed			

Model

Serial number

Date

Machine owner

Inspected by (print)

Inspector signature

Inspector title

Inspector company

Maintenance

Maintenance Inspection Report

Model
Serial number
Date
Hour meter
Machine owner
Inspected by (print)
Inspector signature
Inspector title
Inspector company
Instructions
<ul style="list-style-type: none"> • Make copies of this report to use for each inspection. • Select the appropriate checklist(s) for the type of inspection to be performed.
<input type="checkbox"/> Daily or 8 hours Inspection: A
<input type="checkbox"/> Quarterly or 250 hours Inspection: A+B
<input type="checkbox"/> Semi-annually or 500 hours Inspection: A+B+C
<input type="checkbox"/> Annually or 1000 hours Inspection: A+B+C+D
<input type="checkbox"/> Two year or 2000 hours Inspection: A+B+C+D+E
<ul style="list-style-type: none"> • Place a check in the appropriate box after each inspection procedure is completed. • Use the step-by-step procedures in this section to learn how to perform these inspections. • If any inspection receives an "N", tag and remove the machine from service, repair and re-inspect it. After repair, place a check in the "R" box.
Legend
Y = yes, acceptable
N = no, remove from service
R = repaired

Checklist A	Y	N	R
A-1 Manuals and decals			
A-2 Pre-operation inspect			
A-3 Check the Batteries			
A-4 Check the Engine Oil Level			
A-5 Check the Hydraulic Oil Level			
A-6 Check the Engine Coolant Level			
A-7 Function tests			
A-8 Engine maintenance			
Perform after 40 hours:			
A-9 30 day service			
Perform after 50 hours:			
A-10 Engine maintenance			
Checklist B	Y	N	R
B-1 Battery			
B-2 Electrical wiring			
B-3 Exhaust system			
B-4 Tires and wheels			
B-5 Drive hub oil level			
B-6 Key switch			
B-7 Emergency Stop			
B-8 Horn			
B-9 Drive brakes			
B-10 Drive speed - stowed			
B-11 Drive speed - raised			
B-12 Lubrication			
B-13 Hydraulic oil analysis			

Maintenance

B-14 Engine maintenance			
Checklist C	Y	N	R
C-1 Platform overload			
C-2 Engine maintenance			
Checklist D			
D-1 Return filter element			
D-2 Free-wheel configuration			
D-3 Engine maintenance			
Checklist E	Y	N	R
E-1 Test or replace hydraulic oil			
Perform every 2000 hours:			
E-2 Engine maintenance			
Perform every 3000 hours:			
E-3 Engine maintenance			
Perform every 4000 hours:			
E-4 Engine maintenance			
Perform every 6000 hours:			
E-4 Engine maintenance			
Perform every 12,000 hours:			
E-6 Engine maintenance			

Checklist A Procedures

A-1

Inspect the Manuals and Decals

Maintaining the operator's manual in good condition is essential to safe machine operation. Manuals are included with each machine and should be stored in the container provided in the platform. An illegible or missing manual will not provide safety and operational information necessary for a safe operating condition.

In addition, maintaining all of the safety and instructional decals in good condition is mandatory for safe machine operation. Decals alert operators and personnel to the many possible hazards associated with using this machine. They also provide users with operation and maintenance information. An illegible decal will fail to alert personnel of a procedure or hazard and could result in unsafe operating conditions.

- 1 Check to make sure that the operator's manual is present and complete in the storage container on the platform.
 - 2 Examine the pages of manual to be sure that they are legible and in good condition.
- ⊙ Result: The operator's manual is appropriate for the machine and the manual are legible and in good condition.
 - ⊗ Result: The operator's manual is not appropriate for the machine or the manual is not in good condition or is illegible. Remove the machine from service until the manual is replaced.

- 3 Open the operator's manual to the decals inspection section. Carefully and thoroughly inspect all decals on the machine for legibility and damage.
- ⊙ Result: The machine is equipped with all required decals, and all decals are legible and in good condition.
 - ⊗ Result: The machine is not equipped with all required decals, or one or more decals are illegible or in poor condition. Remove the machine from service until the decals are replaced.
- 4 Always return the manual to the storage container after use.

Note: Contact your authorized DINGLI distributor or DINGLI machinery if replacement manuals or decals are needed.

Maintenance

A-2

Perform Pre-operation Inspection

Completing a Pre-operation Inspection is essential to safe machine operation. The Pre-operation Inspection is a visual inspection performed by the operator prior to each work shift. The inspection is designed to discover if anything is apparently wrong with a machine before the operator performs the function tests. The Pre-operation Inspection also serves to determine if routine maintenance procedures are required.

Complete information to perform this procedure is available in the appropriate operator's manual. Refer to the operator's manual on your machine.

A-3

Check the Batteries



Proper battery condition is essential to good machine performance and operational safety. Improper fluid levels or damaged cables and connections can result in component damage and hazardous conditions.

Note: This check is not required for machines with lithium batteries, sealed batteries, or Maintenance - free batteries.

⚠ WARNING Electrocutation hazard.

Contact with hot or live circuits may result in death or serious injury. Remove all rings, watches and other jewelry.

⚠ WARNING Bodily injury hazard.

Batteries contain acid. Avoid spilling or contacting battery acid. Neutralize battery acid spills with baking soda and water.

- 1 Put on protective clothing and eye wear.
- 2 Be sure that the battery cable connections are tight and free of corrosion.
- 3 Be sure that the battery hold-down bars are secure.
- 4 Remove the battery vent caps.
- 5 Check the battery acid level. If needed, replenish with distilled water to the bottom of the battery fill tube. Do not overfill.
- 6 Install the vent caps.

Note: Adding terminal protectors and a corrosion preventative sealant will help eliminate corrosion on the battery terminals and cables.

A-4**Check the Engine Oil Level**

Maintaining the proper engine oil level is essential to good engine performance and service life.

Operating the machine with an improper oil level can damage engine components.

NOTICE Check the oil level with the engine off.

- 1 Open the engine cover
 - 2 Pull out the lubricating oil dipstick and wipe off a lint-free, clean cloth.
 - 3 Insert the lubricating oil dipstick as it will go.
 - 4 Extract the lubricating oil dipstick and read off the oil level
- ⊙ Result: The oil level must always be between the MIN and MAX mark. Top up to the MAX mark if necessary.

Oil type	5W-30
Oil type – cold conditions	0W-20

A-5**Check the Hydraulic Oil Level**

Maintaining the hydraulic oil at the proper level is essential to machine operation. Improper hydraulic oil levels can damage hydraulic components. Daily checks allow the inspector to identify changes in oil level that might indicate the presence of hydraulic system problems.

NOTICE Perform this procedure with the platform in the stowed position and the engine off.

- 1 Visually inspect the sight of hydraulic oil level from the side of the hydraulic oil tank.
- ⊙ Result: The hydraulic oil level should be within the top 5 cm of the tank.
- 2 Add oil if necessary. Do not overfill.

NOTICE **Original Hydraulic oil specifications: L-HV46**

Customers shall choose the appropriate hydraulic oil according to the ambient temperature used.

Example: L-HV32 or L-HV68

Maintenance

A-6

Check the Engine Coolant Level



Maintaining the engine coolant at the proper level is essential to engine service life. Improper coolant level will affect the engine's cooling capability and damage engine components. Daily checks will allow the inspector to identify changes in coolant level that might indicate cooling system problems.

Check the fluid level in the radiator. Add fluid as needed.

⚠ WARNING Bodily injury hazard. Fluids in the radiator are under pressure and extremely hot. Use caution when removing cap and adding fluids.

A-7

Perform Function Tests

Completing the function tests is essential to safe machine operation. Function tests are designed to discover any malfunctions before the machine is put into service. A malfunctioning machine must never be used. If malfunctions are discovered, the machine must be tagged and removed from service.

Complete information to perform this procedure is available in the appropriate operator's manual. Refer to the Operator's Manual on your machine.

Maintenance

A-8

Perform Engine Maintenance



Engine specifications require that this procedure be performed every 8 hours or daily, whichever comes first.

Required maintenance procedures and additional engine information is available in the engine operator's manual.

A-10

Perform Engine Maintenance



Engine specifications require that this one-time procedure be performed after 50 hours of operation.

Required maintenance procedures and additional engine information is available in the engine operator's manual.

A-9

Perform 30 Day Service



The 30 day maintenance procedure is a one time procedure to be performed after the first 30 days or 40 hours of usage. After this interval, refer to the maintenance tables for continued scheduled maintenance.

- 1 Perform the following maintenance procedures:
 - B-4 Inspect the Tires and Wheels (including lug nut torque)
 - B-14 Perform Engine Maintenance

Maintenance

Checklist B Procedures

B-1

Inspect the Batteries



DINGLI requires that this procedure be performed every 250 hours or quarterly, whichever comes first.

Proper battery condition is essential to good machine performance and operational safety. Improper fluid levels or damaged cables and connections can result in component damage and hazardous conditions.

⚠ WARNING Electrocution / burn hazard. Contact with electrically charged circuits could result in death or serious injury. Remove all rings, watches and other jewelry.

⚠ WARNING Bodily injury hazard. Batteries contain acid. Avoid spilling or contacting battery acid. Neutralize battery acid spills with baking soda and water.

- 1 Put on protective clothing and eye wear.
- 2 Be sure that the battery cable connections are free of corrosion.

Note: Adding terminal protectors and a corrosion preventative sealant will help eliminate corrosion on the battery terminals and cables.

- 3 Be sure that the battery retainers and cable connections are tight.
- 4 Fully charge the battery. Allow the battery to rest 24 hours before performing this procedure to allow the battery cells to equalize.

Models without maintenance-free or sealed batteries:

- 5 Remove the battery vent caps and check the specific gravity of each battery cell with a hydrometer. Note the results.
- 6 Check the ambient air temperature and adjust the specific gravity reading for each cell as follows:
 - Add 0.004 to the reading of each cell for every 5.5° C above 26.7° C.
 - Subtract 0.004 from the reading of each cell for every 5.5° C below 26.7° C.
- ⊙ Result: All battery cells display an adjusted specific gravity of 1.277 or higher. The battery is fully charged. Proceed to step 10.
- ⊗ Result: One or more battery cells display a specific gravity of 1.276 or below. Proceed to step 7.
- 7 Perform an equalizing charge OR fully charge the batteries and allow the battery to rest at least 6 hours.
- 8 Remove the battery vent caps and check the specific gravity of each battery cell with a hydrometer. Note the results.
- 9 Check the ambient air temperature and adjust the specific gravity reading for each cell as follows:
 - Add 0.004 to the reading of each cell for every 5.5° C above 26.7° C.
 - Subtract 0.004 from the reading of each cell for every 5.5° C below 26.7° C.
- ⊙ Result: All battery cells display a specific gravity of 1.277 or greater. The battery is

Maintenance

fully charged. Proceed to step 10.

- ⊗ Result: The difference in specific gravity readings between cells is greater than 0.1 OR the specific gravity of one or more cells is less than 1.177. Replace the battery.
- 10 Check the battery acid level. If needed, replenish with distilled water to 1/8 inch | 3 mm below the bottom of the battery fill tube. Do not overfill.
- 11 Install the vent caps and neutralize any electrolyte that may have spilled.

All models:

- 12 Check each battery pack and verify that the batteries are wired correctly.
- 13 Inspect the battery charger plug and pigtail for damage or excessive insulation wear. Replace as required.
- 14 Connect the battery charger to a properly grounded 110 - 230V / 50 – 60 Hz single phase AC power supply.
- ⊙ Result: The charger should operate and begin charging the batteries.
- ⊗ Result: If, simultaneously, the charger alarm sounds and the LEDs blink, correct the charger connections at the fuse and battery. The charger will then operate correctly and begin charging the batteries.

Note: For best results, use an extension of adequate size with a length no longer than 15m.

Note: If you have any further questions regarding the battery charger operation, please contact the DINGLI Service Department.

B-2**Inspect the Electrical Wiring**

DINGLI requires that this procedure be performed every 250 hours or quarterly, whichever comes first.

Maintaining electrical wiring in good condition is essential to safe operation and good machine performance. Failure to find and replace burnt, chafed, corroded or pinched wires could result in unsafe operating conditions and may cause component damage.

⚠ WARNING Electrocution / burn hazard. Contact with electrically charged circuits could result in death or serious injury. Remove all rings, watches and other jewelry.

- 1 Inspect the underside of the chassis for damaged or missing ground strap(s).
- 2 Inspect the following areas for burnt, chafed, corroded and loose wires:
 - Ground control panel
 - Hydraulic power unit module tray
 - Battery pack module tray
 - Platform controls
 - Engine
- 3 Inspect for a liberal coating of dielectric grease in the following locations:
 - Between the ECM and platform controls
 - Engine ECM
 - All wire harness connectors
 - Level sensor

Maintenance

4 Turn the key switch to ground control and turn the ground red Emergency Stop button clockwise to the on position pull out the platform red Emergency Stop button to the on position.

5 Start the engine from the ground controls and raise the platform approximately 5.5m from the ground.

6 Use the Safety Arm. Stop the engine.

⚠ WARNING Crushing hazard. Keep hands clear of the safety arm when lowering the platform.

7 Inspect the center chassis area and scissor arms for burnt, chafed and pinched cables.

8 Inspect the following areas for burnt, chafed, corroded, pinched and loose wires:

- Scissor arms
- ECM to platform controls
- Power to platform wiring

9 Inspect for a liberal coating of dielectric grease in all connections between the ECM and the platform controls.

10 Raise the platform and return the safety arm to the stowed position.

11 Lower the platform to the stowed position and turn the machine off.

B-3

Check the Exhaust System



Dingli requires that this procedure be performed every 250 hours or quarterly, whichever comes first.

Maintaining the exhaust system is essential to good engine performance and service life. Running the engine with a damaged or leaking exhaust system can cause component damage and unsafe operating conditions.

⚠ WARNING Bodily injury hazard. Do not inspect while the engine is running. Remove the key to secure from operation.

⚠ CAUTION Bodily injury hazard. Beware of hot engine components. Contact with hot engine components may cause severe burns.

- 1 Open the cover.
- 2 Be sure that all fasteners are tight.
- 3 Inspect all welds for cracks.
- 4 Inspect for exhaust leaks; i.e., carbon buildup around seams and joints.

Maintenance

B-4

Inspect the Tires and Wheels



Dingli requires that this procedure be performed every 250 hours or quarterly, whichever comes

Maintaining the tires and wheels in good condition is essential to safe operation and good performance. Tire and/or wheel failure could result in a machine tip-over. Component damage may also result if problems are not discovered and repaired in a timely fashion.

- 1 Check all tire treads and sidewalls for cuts, cracks, punctures and unusual wear.
- 2 Check each wheel for damage, bends and cracks.
- 3 Check each lug nut for proper torque.

Lug nut torque	450Nm
----------------	-------

B-5

Check the Oil Level in the Drive Hubs



Dingli requires that this procedure be performed every 250 hours or quarterly, whichever comes

Failure to maintain proper drive hub oil levels may cause the machine to perform poorly and continued use may cause component damage.

- 1 Before draining oil it is mandatory to rotate the planetary gear reduction in order to move the oil plug in filling position, then loosen the oil plug and wait until the internal pressure is completely released.
- 2 Remove the plug located and check the oil level.
- ⊙ Result: The oil level should be even with the bottom of the plug hole.
- 3 If necessary, remove the plug and add oil until the oil level.
- 4 Apply pipe thread sealant to the plug(s), and then install the plug(s) in the drive hub.
- 5 Repeat this procedure for each drive hub.

Maintenance

B-6

Test the Key Switch

Dingli requires that this procedure be performed every 250 hours or quarterly, whichever comes first.

Proper key switch action and response is essential to safe machine operation. Failure of the key switch to activate the appropriate control panel could cause a hazardous operating situation.

- 1 Turn the ground red Emergency Stop button clockwise to the on position. Pull out the platform red Emergency Stop button to the on position.
- 2 Turn the key switch to ground controls and start the engine from ground controls.
- 3 Check any machine function from the platform controls.
- ⊙ Result: The machine functions should not operate.
- 4 Turn the key switch to platform controls and start the engine from platform controls.
- 5 Check any machine function from the ground controls.
- ⊙ Result: The machine functions should not operate.
- 6 Turn the key switch to the off position.
- ⊙ Result: The engine should stop and no functions should operate.

B-7

Test the Emergency Stop

Dingli requires that this procedure be performed every 250 hours or quarterly, whichever comes first.

A properly functioning Emergency Stop is essential for safe machine operation. An improperly operating red Emergency Stop button will fail to shut off power and stop all machine functions, resulting in a hazardous situation.

As a safety feature, selecting and operating the ground controls will override the platform controls, except the platform red Emergency Stop button.

- 1 Start the engine from ground controls.
- 2 Push in the red Emergency Stop button to the off position.
- ⊙ Result: The engine should shut off and no machine functions should operate.
- 3 Start the engine from platform controls.
- 4 Push in the red Emergency Stop button to the off position.
- ⊙ Result: The engine should shut off and no machine functions should operate.

Note: The red Emergency Stop button at the ground or platform controls will stop all machine operation without regard to the position of the key switch.

B-8**Test the Automotive-style Horn**

Dingli requires that this procedure be performed every 250 hours or quarterly, whichever comes first.

A functional horn is essential to safe machine operation. The horn is activated at the platform controls and sounds at the ground as a warning to ground personnel. An improperly functioning horn will prevent the operator from alerting ground personnel of hazards or unsafe conditions.

- 1 Start the engine from platform controls.
- 2 Push down the horn button at the platform controls.

⊙ Result: The horn should sound.

Note: If necessary, the horn can be adjusted to obtain the loudest volume by turning the adjustment screw near the wire terminals on the horn.

B-9**Test the Drive Brakes**

Dingli requires that this procedure be performed every 250 hours or quarterly, whichever comes first.

Proper brake action is essential to safe machine operation. The drive brake function should operate smoothly, free of hesitation, jerking and unusual noise.

Hydraulically-released individual wheel brakes can appear to operate normally when they are actually not fully operational.

- 1 Mark a test line on the ground for reference.
- 2 Start the engine from the platform controls.
- 3 Choose a point on the machine; i.e., contact patch of a tire, as a visual reference for use when crossing the test line.
- 4 Bring the machine to top drive speed before reaching the test line. Release the function enable switch on the control handle or release the control handle when your reference point on the machine crosses the test line.
- 5 Measure the distance between the test line and your machine reference point.

⊙ Result: The machine stops within the specified braking distance. No action required.

⊘ Result: The machine does not stop within the specified braking distance.

Note: The brakes must be able to hold the machine on any slope it is able to climb.

Maintenance

- 6 Replace the brakes and repeat this procedure beginning with step 1.

Braking distance, maximum

High range on paved surface 120cm

B-10

Test the Drive Speed - Stowed Position



Dingli requires that this procedure be performed every 250 hours or quarterly, whichever comes

Proper drive function movement is essential to safe machine operation. The drive function should respond quickly and smoothly to operator control. Drive performance should also be free of hesitation, jerking and unusual noise over the entire proportionally control led speed range.

- 1 Create start and finish lines by marking two lines on the ground 12.2m apart.
- 2 Turn the key switch to platform controls
- 3 Pull out the platform red Emergency Stop button to the on position.
- 4 Turn the ground red Emergency Stop button clockwise to the on position.
- 5 Start the engine from the platform controls.
- 6 Lower the platform to the stowed position.
- 7 Choose a point on the machine; i.e., contact patch of a tire, as a visual reference for use when crossing the start and finish lines.
- 8 Bring the machine to maximum drive speed before reaching the start line. Begin timing when your reference point on the machine crosses the start line.
- 9 Continue at full speed and note the time when the machine reference point passes over the finish line. The time is less than 11 sec.

B-11**Test the Drive Speed -Raised Position**

Dingli requires that this procedure be performed every 250 hours or quarterly, whichever comes first.

Proper drive function movement is essential to safe machine operation. The drive function should respond quickly and smoothly to operator control. Drive performance should also be free of hesitation, jerking and unusual noise over the entire proportionally control led speed range.

- 1 Create start and finish lines by marking two lines on the ground 12.2m apart.
- 2 Turn the key switch to platform controls
- 3 Pull out the platform red Emergency Stop button to the on position.
- 3 Turn the ground red Emergency Stop button clockwise to the on position.
- 4 Start the engine from the platform controls.
- 5 Press and hold the function enable button. Raise the platform approximately 4.5m from the ground.
- 6 Choose a point on the machine; i.e., contact patch of a tire, as a visual reference for use when crossing the start and finish lines.
- 7 Bring the machine to maximum drive speed before reaching the start line. Begin timing when your reference point on the machine crosses the start line.
- 8 Continue at full speed and note the time when the machine reference point passes over the finish line. The time is less than 146 sec.

B-12**Lubrication**

Dingli requires that this procedure be performed every 100 hours or month, whichever comes first.

Good lubrication is essential to machine performance and service life. Failure to lubricate may cause the machine to perform poorly and continued use may cause component damage.

Lubrication involves:

- The lubricating points on the scissor joints
- The lubricating points on the chassis.
- The lubricating points on the platform

The following points must be lubricated on the scissor joint in particular:

- Scissor shaft
- Sliding blocks

Maintenance

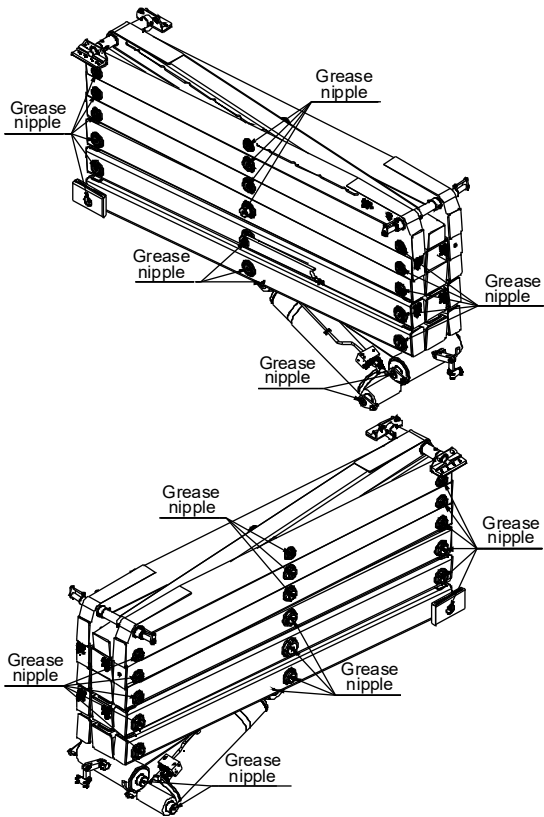

The following points must be lubricated on the chassis in particular:

- Steering
- lifting cylinder
- Sliding tracks of the sliding blocks

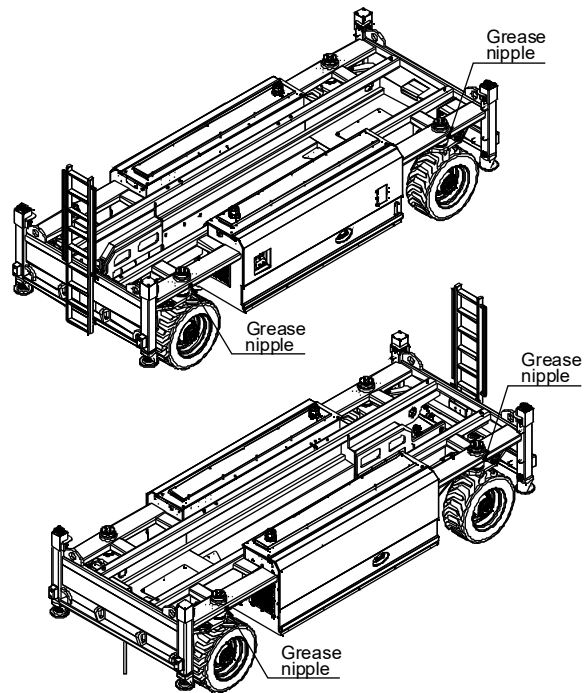

The following points must be lubricated on the platform in particular:

- Sliding blocks - sliding tracks

Note: Lubricate all grease points of the aerial work platform only slightly when re-lubricating, but always ensure sufficient lubrication. Use high temperature-resistant grease.

Maintenance**B-13****Perform Hydraulic Oil Analysis**

Dingli requires that this procedure be performed every 250 hours or quarterly, whichever comes first.

Replacement or testing of the hydraulic oil is essential for good machine performance and service life. Dirty oil and a clogged suction strainer may cause the machine to perform poorly and continued use may cause component damage. Extremely dirty conditions may require oil changes to be performed more often.

Note: Before replacing the hydraulic oil, the oil may be tested by an oil distributor for specific levels of contamination to verify that changing the oil is necessary. If the hydraulic oil is not replaced at the two year inspection, test the oil quarterly. Replace the oil when it fails the test. See E-1, Test or Replace the Hydraulic Oil.

B-14**Perform Engine Maintenance**

Engine specifications require that this procedure be performed every 250 hours or quarterly, whichever comes first.

Required maintenance procedures and additional engine information is available in the engine operator's manual.

Maintenance

Checklist C Procedures

C-1

Test the Platform Overload System



Dingli specifications require that this procedure be performed every 500 hours or semi-annually, whichever comes first OR when the machine fails to lift the maximum rated load.

Testing the platform overload system regularly is essential to safe machine operation. Continued use of an improperly operating platform overload system could result in the system not sensing an overloaded platform condition. Machine stability could be compromised resulting in the machine tipping over.

Note: Perform this procedure with the machine on a firm, level surface that is free of obstructions.

- 1 Turn the ground red Emergency Stop button clockwise to the on position. Pull out the platform red Emergency Stop button to the on position.
 - 2 Turn the key switch to platform controls and start the engine from platform controls.
 - 3 Determine the maximum platform capacity.
 - 4 Using a suitable lifting device, place an appropriate test weight equal to the maximum platform capacity in the center of the platform floor.
- ⊙ Result: The overload alarm at the platform controls should not sound, indicating a normal condition.

⊗ Result: The overload alarm at the platform controls sounds. Calibrate the platform overload system.

- 5 Add an additional weight to the platform not to exceed 20% of the maximum rated load.

⊙ Result: The overload alarm at the platform controls sound, indicating a normal condition.

⊗ Result: The overload alarm at the platform controls does not sound. Calibrate the platform overload system.

- 6 Test all machine functions from the platform controls.

⊙ Result: All platform control functions should not operate.

- 7 Turn the key switch to ground control. and start the engine from ground controls.

- 8 Test all machine functions from the ground controls

⊙ Result: All ground control functions should not operate.

- 9 Lift the test weight off the platform floor using a suitable lifting device.

⊙ Result: The overload alarm at the platform controls should not sound, indicating a normal condition.

⊗ Result: The overload alarm at the platform controls sounds. Calibrate the platform overload system.

Maintenance

- 10 Test all machine functions from the ground controls.
 - ⊙ Result: All ground control functions should operate.
- 11 Turn the key switch to platform control.
And start the engine from platform controls
- 12 Test all machine functions from the platform controls.
 - ⊙ Result: All platform control functions should operate.

C-2

Perform Engine Maintenance



Engine specifications require that this procedure be performed every 500 hours or semi-annually, whichever comes first.

Required maintenance procedures and additional engine information is available in the engine operator's manual.

Maintenance

Checklist D Procedures

D-1

Replace the Hydraulic Tank Return Filter Element



DINGLI requires that this procedure be performed every 1000 hours or annually, whichever comes first.

Replacement of the hydraulic tank return filter is essential for good machine performance and service life. A dirty or clogged filter may cause the machine to perform poorly and continued use may cause component damage. Extremely dirty conditions may require that the filter be replaced more often.

CAUTION Beware of hot oil. Contact with hot oil may cause severe burns.

- 1 Open the cover.
- 2 Tag and disconnect the hydraulic tank return line .Cap the fitting on the filter head.
- 3 Clean the area around the oil filter. Remove the filter with an oil filter wrench.
- 4 Apply a thin layer of oil to the new oil filter gasket.
- 5 Install the new filter and tighten it securely by hand.
- 6 Use a permanent ink marker to write the date and number of hours from the hour meter onto the filter.
- 7 Start the engine from ground controls.
- 8 Inspect the filter and related components to be sure that there are no leaks.
- 9 Clean up any oil that may have spilled.

D-2

Check the Free-wheel Configuration



Dingli specifications require that this procedure be performed every 1000 hours or annually, whichever comes first.

Proper use of the free-wheel configuration is essential to safe machine operation. The free-wheel configuration is used primarily for towing. A machine configured to free-wheel without operator knowledge may cause death or serious injury and property damage.

WARNING Collision hazard. Select a work site that is firm and level.

NOTICE Component damage hazard. If the machine must be towed, do not exceed 4.0km/h.

- 1 Chock the front wheels.
- 2 Center a lifting jack of ample capacity (50,000 lbs / 25,000 kg) under the drive chassis between the rear wheels.
- 3 Lift the wheels off the ground and place blocks under the drive chassis for support.

WARNING Crushing hazard. The chassis could fall if not properly supported.

- 4 Release the brake.
- 5 Manually rotate each rear wheel.
- ⊙ Result: Each wheel should rotate with minimum effort.
- 6 Reset the brake. Rotate each wheel to check for engagement. Raise the machine and remove the blocks. Lower the machine.

Maintenance

- 7 Chock the rear wheels.
- 8 Center a lifting jack of ample capacity (50,000 lbs / 25,000 kg) under the drive chassis between the front wheels.
- 9 Lift the wheels off the ground and place blocks under the drive chassis for support.

⚠ WARNING Crushing hazard. The chassis could fall if not properly supported.

- 10 Release the brake.
- 11 Manually rotate each front wheel.
- ⊙ Result: Each wheel should rotate with minimum effort.
- 12 Reset the brake. Rotate each wheel to check for engagement. Raise the machine and remove the blocks. Lower the machine.

D-3

Perform Engine Maintenance



Engine specifications require that this procedure be performed every 1000 hours or annually, whichever comes first.

Required maintenance procedures and additional engine information is available in the engine operator's manual.

Maintenance

Checklist E Procedures

E-1

Test or Replace the Hydraulic Oil



DINGLI requires that this procedure be performed every 2000 hours or every two years, whichever comes first.

Replacement or testing of the hydraulic oil is essential for good machine performance and service life. Dirty oil and suction strainers may cause the machine to perform poorly and continued use may cause component damage. Extremely dirty conditions may require oil changes to be performed more frequently.

NOTICE Component damage hazard.

The work area and surfaces where this procedure will be performed must be clean and free of debris that could get into the hydraulic system.

Before replacing the hydraulic oil, the oil may be tested by an oil distributor for specific levels of contamination to verify that changing the oil is necessary. If the hydraulic oil is not replaced at the two year inspection, test the oil quarterly. Replace the oil when it fails the test.

In extreme cold conditions, -6°C and below, warm the engine for 5 minutes before operating to prevent hydraulic system damage.

WARNING Electrocution / burn hazard: Contact with electrically charged circuits could result in death or serious injury. Remove all rings, watches and other jewelry.

WARNING Bodily injury hazard.

Spraying hydraulic oil can penetrate and burn skin. Loosen hydraulic connections very slowly to allow the oil pressure to dissipate gradually. Do not allow oil to squirt or spray.

- 1 Disconnect the battery pack from the machine.
- 2 Open the power unit module cover.
- 3 Remove the oil drain plug at bottom Drain all of the oil into a suitable container.
- 4 Tag and disconnect the hydraulic tank return line from the hydraulic filter head and remove the line from the tank. Cap the fitting on the filter head.
- 5 Tag and disconnect the hydraulic pump inlet line and remove the line from the tank. Cap the fitting on the pump.
- 6 Remove the hydraulic tank retaining fasteners and remove the hydraulic tank from the machine.
- 7 Open the tank cover and remove the oil filter.
- 8 Remove the breather cap from the hydraulic tank.
- 9 Clean the inside of the hydraulic tank using a mild solvent. Allow the tank to dry completely.
- 10 Tighten the drain plug.

Maintenance

- 11 Install a new oil filter onto the tank and install the tank cover.
- 12 Install the breather cap onto the hydraulic tank.
- 13 Install the hydraulic tank and install and tighten the hydraulic tank retaining fasteners.
- 14 Install the hydraulic pump inlet line into the tank. Install the fitting onto the pump and torque.
- 15 Install the hydraulic pump return line into the tank. Install the fitting onto the hydraulic filter head and torque.
- 16 Add the tank with hydraulic oil until the fluid is equal in the hydraulic tank.

⚠ WARNING Component damage hazard.

The pump can be damaged if operated without oil. Be careful not to empty the hydraulic tank while in the process of filling the hydraulic system. Do not allow the pump to cavitate.

E-2

Perform Engine Maintenance



Engine specifications require that this procedure be performed every 2000 hours or two years, whichever comes first.

Required maintenance procedures and additional engine information is available in the engine operator's manual.

Maintenance

E-3

Perform Engine Maintenance



Engine specifications require that this procedure be performed every 3000 hours,

Required maintenance procedures and additional engine information is available in the engine operator's manual.

E-5

Perform Engine Maintenance



Engine specifications require that this procedure be performed every 6000 hours.

Required maintenance procedures and additional engine information is available in the engine operator's manual.

E-4

Perform Engine Maintenance



Engine specifications require that this procedure be performed every 4000 hours,

Required maintenance procedures and additional engine information is available in the engine operator's manual.

E-6

Perform Engine Maintenance



Engine specifications require that this procedure be performed every 12,000 hours.

Required maintenance procedures and additional engine information is available in the engine operator's manual.

Fault State

In the fault state, a fault code from the list will be displayed flashing at a 1 Hz rate (0.5 seconds on, 0.5 off).

List of Fault Codes

Display for Platform	Display for Ground	Description	Description
01	System fault	Main ECU System Fault	Replace Main ECU
02	PCU Communication fault	ECU/Platform Communication Fault	Check the wiring, check the platform / ground control
05	Leg Switch Fault	Leg Switch Fault	check the wiring, replace the valve
06	Brake Fault	Brake Fault	check the wiring, replace the valve
07	Turn Brake Fault	Turn Brake Fault	check the wiring, replace the valve
10	High Speed valve fault	High Speed valve fault	check the wiring, replace the valve
13	Load sensor fault	Load Sensor Fault	Check the sensor, check the wiring
14	angle sensor fault	Angle Sensor Fault	Check the sensor, check the wiring
20	chassis start button fault	Chassis Start Switch ON at power-up	Check the switch, check the wiring
21	chassis choke button fault	Chassis Choke Switch ON at power-up	Check the switch, check the wiring
22	chassis up button fault	Chassis Up Switch ON at power-up	Check the switch, check the wiring
23	chassis enable button fault	Chassis Lift Switch ON at power-up	Check the switch, check the wiring
24	chassis down button fault	Chassis Down Switch ON at power-up	Check the switch, check the wiring
25	PCU steer left button fault"	Platform Left Turn Switch ON at power-up	Check the switch, replace the platform
26	PCU steer right button fault	Platform Right Turn Switch ON at power-up	Check the switch, replace the platform

Maintenance

Display for Platform	Display for Ground	Description	Repair
27	PCU enable button fault	Platform Drive Enable Switch ON at power-up	Check the switch, replace the platform
28	PCU joystick out of neutral fault	Platform Joystick not in neutral ON at power-up	Check the switch, replace the platform
31	PCU choke button fault	Platform Choke Switch ON at power-up	Check the switch, replace the platform
32	PCU start button fault	Platform Start Switch ON at power-up	Check the switch, replace the platform
33	PCU LF outrigger button fault	Platform Left Front Outrigger Enable Switch ON at power-up	Check the switch, replace the platform
34	PCU RF outrigger button fault	Platform Right Front Outrigger Enable Switch ON at power-up	Check the switch, replace the platform
35	PCU LR outrigger button fault	Platform Left Rear Outrigger Enable Switch ON at power-up	Check the switch, replace the platform
36	PCU RR outrigger button fault	Platform Right Rear Outrigger Enable Switch ON at power-up	Check the switch, replace the platform
37	PCU auto outrigger button fault	Platform Outrigger Auto Level Enable Switch ON at power-up	Check the switch, replace the platform
43	Outrigger not extended	Outrigger not extended	Check limit switch Check wiring
44	Down limit switch fault	Limit down switch fault	Check angle sensor, Check limit switch Check wiring
52	Proportional valve fault	Proportional valve fault	check the wiring, replace the valve
53	Proportional down valve fault	Proportional down valve fault	check the wiring, replace the valve
54	UP valve fault	UP valve fault	check the wiring, replace the valve
55	Down valve fault	Down valve fault	check the wiring, replace the valve
56	Steer forward right valve fault	Steer forward right valve fault	check the wiring, replace the valve
57	Steer forward left valve fault	Steer forward left valve fault	check the wiring, replace the valve

Maintenance

Display for Platform	Display for Ground	Description	Repair
58	Brake valve fault	Brake valve fault	check the wiring, replace the valve
66	Engine oil under pressure fault	Oil Pressure Fault	check the wiring, replace the sensor
67	Engine water over temperature fault	Water Temperature Fault	check the wiring, replace the sensor
68	Battery low voltage fault	Low Battery Voltage	check the wiring, check the battery
69	Engine under speed fault	Low RPM Fault	check the wiring, check the engine
70	Engine over speed fault	High RPM Fault	check the wiring, check the engine
71	Out platform valve fault	Out platform valve fault	check the wiring, replace the valve
72	In platform valve fault	In platform valve fault	check the wiring, replace the valve
73	Steer reverse right valve fault	Steer reverse right valve fault	check the wiring, replace the valve
74	Steer reverse left valve fault	Steer reverse left valve fault	check the wiring, replace the valve
79	Engine Communication fault	Engine Communication fault	Check Engine diagnostic device
81	LF outrigger valve fault	LF outrigger valve fault	check the wiring, replace the valve
82	LR outrigger valve fault	LR outrigger valve fault	check the wiring, replace the valve
83	RF outrigger valve fault	RF outrigger valve fault	check the wiring, replace the valve
84	RR outrigger valve fault	RR outrigger valve fault	check the wiring, replace the valve
85	Extend outrigger valve fault	Extend outrigger valve fault	check the wiring, replace the valve
86	Retract outrigger valve fault	Retract outrigger valve fault	check the wiring, replace the valve
88	Regeneration Needed	Regeneration Needed	Regeneration

Maintenance

Display for Platform	Display for Ground	Description	Repair
89	Regeneration Active	Regeneration Active	Waiting for Regeneration
90	Factory Test Mode	Factory Test Mode	Close Factory Test Mode
91	Over Steering Angle Fault	Over Steering Angle Fault	Check Steering Angle
92	Clean the DPF	Clean the DPF	Clean the DPF
93	Front Prop Fault	Drive Forward Prop Coil Fault	check the wiring, replace the valve
94	Back Prop Fault	Drive reverse Prop Coil Fault	check the wiring, replace the valve
OL	Overload fault	Platform Overload Fault	Remove the excess load immediately.
LL	Tilt fault	Machine Tilted Beyond Safe Limits Fault	check the wiring, replace the sensor

For more information, please consult the appropriate Dingli Service Dept.

Hydraulic Schematic - Function model

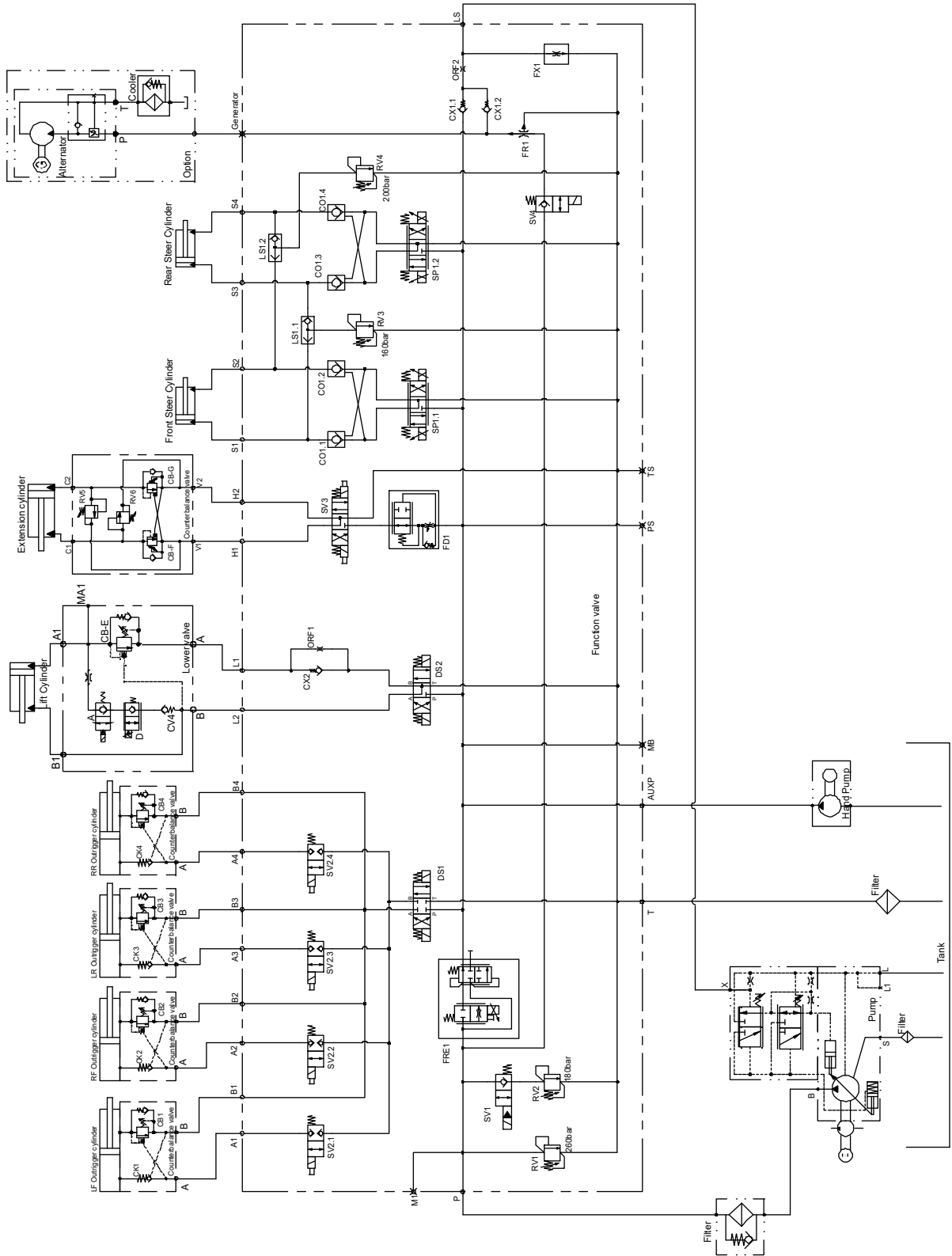

Schematic

Hydraulic Schematic - Drive model

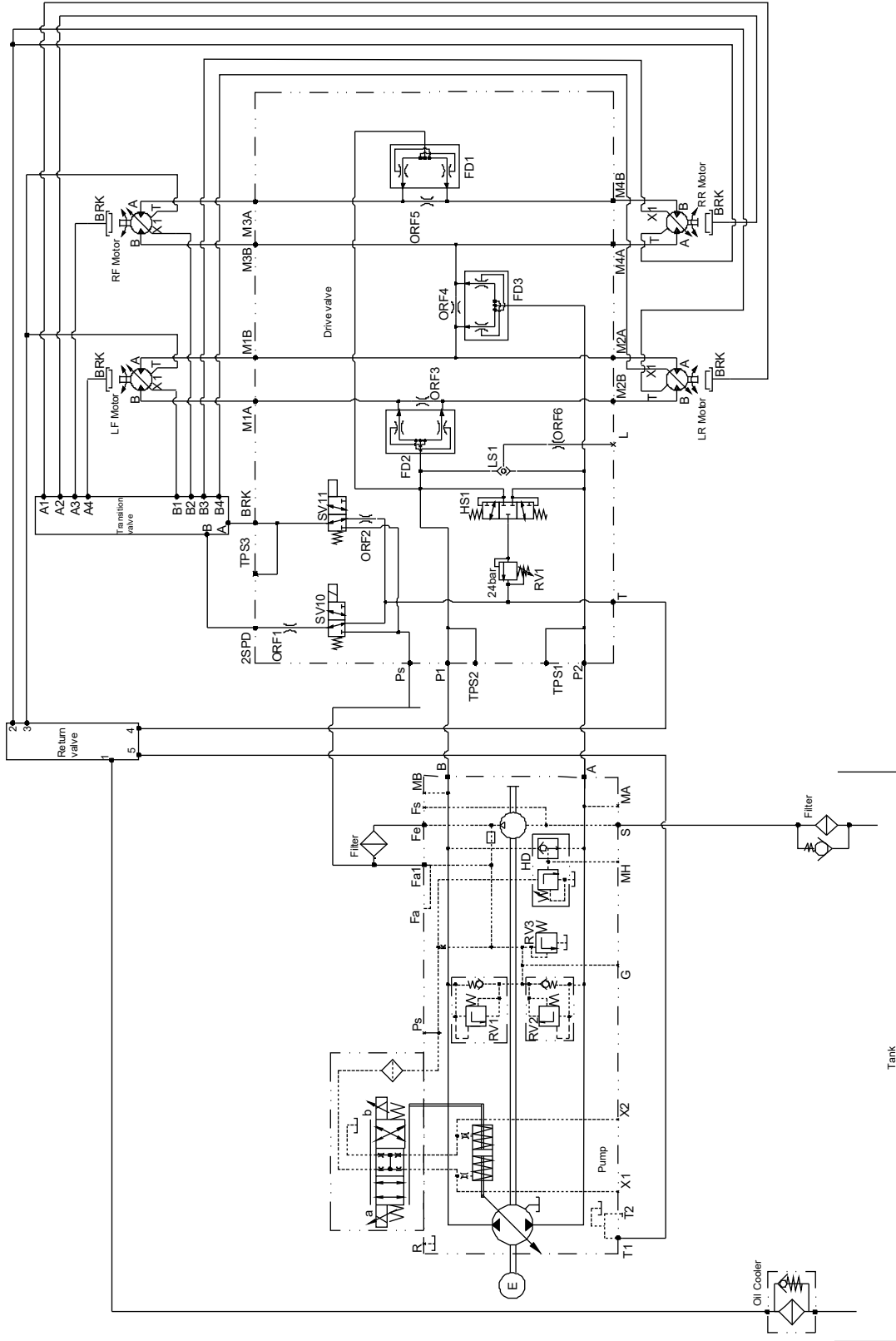

Zhejiang Dingli Machinery Co., Ltd.

No.188 Qihang Road. Deqing Zhejiang P.R.
China 313219

Tel: +86-572-8681688

Fax: +86-572-8681690

Web: www.cndingli.com

E-mail: market@cndingli.com

DINGLI