

# Genie®



## Operator's Manual

*with Maintenance Information*

Fourth Edition  
Second Printing  
Part No. 110018

**S<sup>TM</sup>-60**

**S<sup>TM</sup>-65**

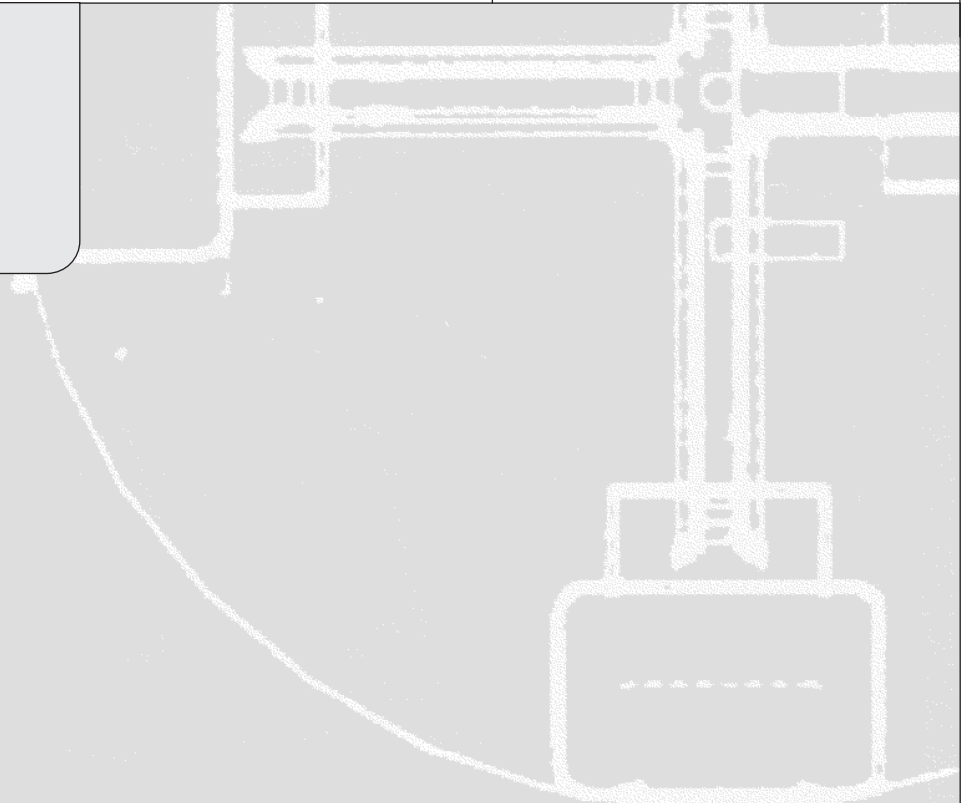

---

## Important

Read, understand and obey these safety rules and operating instructions before operating this machine. Only trained and authorized personnel shall be permitted to operate this machine. This manual should be considered a permanent part of your machine and should remain with the machine at all times. If you have any questions, call Genie Industries.

---

## Contents

	Page
Safety Rules .....	1
Legend .....	8
Controls .....	9
Pre-operation Inspection .....	12
Maintenance .....	14
Function Tests .....	17
Workplace Inspection .....	22
Operating Instructions .....	23
Transport and Lifting Instructions .....	29
Decals .....	32
Specifications .....	36

---

## Contact us:

Internet: <http://www.genielift.com>  
 e-mail: [techpub@genieind.com](mailto:techpub@genieind.com)

---

Copyright © 1995 by Genie Industries

First Edition: Third Printing, October 1996

Second Edition: Fifth Printing, July 2000

Third Edition: Second Printing, May 2004

Fourth Edition: Second Printing, August 2006

"Genie" is a registered trademark of Genie Industries in the U.S.A. and many other countries. "S" is a trademark of Genie Industries.

These machines comply with ANSI/SIA 92.5-1992.

 Printed on recycled paper

Printed in U.S.A.

# Safety Rules



---

## Danger

Failure to obey the instructions and safety rules in this manual will result in death or serious injury.

---

## Do Not Operate Unless:

- You learn and practice the principles of safe machine operation contained in this operator's manual.

### 1 Avoid hazardous situations.

**Know and understand the safety rules before going on to the next section.**

2 Always perform a pre-operation inspection.

3 Always perform function tests prior to use.

4 Inspect the workplace.

5 Only use the machine as it was intended.

- You read, understand and obey the manufacturer's instructions and safety rules—safety and operator's manuals and machine decals.
- You read, understand and obey employer's safety rules and worksite regulations.
- You read, understand and obey all applicable governmental regulations.
- You are properly trained to safely operate the machine.

SAFETY RULES

### Electrocution Hazards

This machine is **not** electrically insulated and will **not** provide protection from contact with or proximity to electrical current.

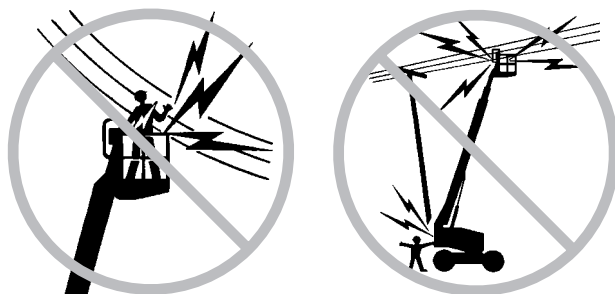

Maintain safe distances from electrical power lines and apparatus in accordance with applicable governmental regulations and the following chart.

Voltage Phase to Phase	Minimum Safe Approach Distance	
	Feet	Meters
0 to 300V	Avoid Contact	
300V to 50KV	10	3.05
50KV to 200KV	15	4.60
200KV to 350KV	20	6.10
350KV to 500KV	25	7.62
500KV to 750KV	35	10.67
750KV to 1000KV	45	13.72

Allow for platform movement, electrical line sway or sag and beware of strong or gusty winds.

Keep away from the machine if it contacts energized power lines. Personnel on the ground or in the platform must not touch or operate the machine until energized power lines are shut off.

Do not operate the machine during lightning or storms.

Do not use the machine as a ground for welding unless the machine is equipped with the weld line to platform option and it is properly connected.

### Tip-over Hazards

Occupants, equipment and materials shall not exceed the maximum platform capacity.

Maximum platform capacity	500 lbs	227 kg
Maximum platform capacity S-60 with 6 Ft Platform with proper counterweight configuration	750 lbs	340 kg
Maximum occupants	2	

The weight of options and accessories, such as pipe cradles, panel cradles and welders, will reduce the rated platform capacity and must be factored into the total platform load. See the decals with the options.

Do not raise or extend the boom unless the machine is on a firm, level surface.

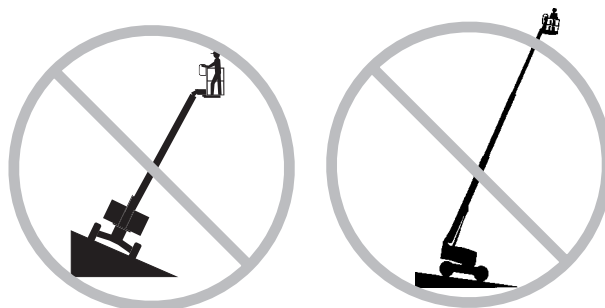

Do not depend on the tilt alarm as a level indicator. The tilt alarm sounds in the platform only when the machine is on a severe slope.

**SAFETY RULES**

If the tilt alarm sounds:

Do not extend, rotate or raise the boom above horizontal. Move the machine to a firm, level surface before raising the platform. If the tilt alarm sounds when the platform is raised, use extreme caution to retract the boom and lower the platform. Do not rotate the boom while lowering. Move the machine to a firm, level surface before raising the platform.

Do not use the platform controls to free a platform that is caught, snagged or otherwise prevented from normal motion by an adjacent structure. All personnel must be removed from the platform before attempting to free the platform using the ground controls.

Do not raise the boom when wind speeds may exceed 28 mph / 12.5 m/s. If wind speeds exceed 28 mph / 12.5 m/s when the boom is raised, lower the boom and do not continue to operate the machine.

Do not operate the machine in strong or gusty winds. Do not increase the surface area of the platform or the load. Increasing the area exposed to the wind will decrease machine stability.



Use extreme care and slow speeds while driving the machine in the stowed position across uneven terrain, debris, unstable or slippery surfaces and near holes and drop-offs.

Do not alter or disable the limit switches.

Do not drive the machine on or near uneven terrain, unstable surfaces or other hazardous conditions with the boom raised or extended.

Do not drive the machine on a slope that exceeds the maximum uphill, downhill or side slope rating of the machine. Slope rating applies only to machines in the stowed position.

**Maximum slope rating, stowed position, 2WD**

Counterweight uphill	30% (17°)
Counterweight downhill	10% (6°)
Side slope	25% (14°)

**Maximum slope rating, stowed position, 4WD**

Counterweight uphill	45% (24°)
Counterweight downhill	30% (17°)
Side slope	25% (14°)

Note: Slope rating is subject to ground conditions and adequate traction.

Do not push off or pull toward any object outside of the platform.

**Maximum allowable side force - ANSI & CSA**  
150 lbs / 667 N

**Maximum allowable manual force - CE & Australia**  
90 lbs / 400 N

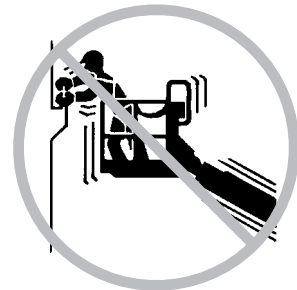

Do not alter or disable machine components that in any way affect safety and stability.

Do not replace items critical to machine stability with items of different weight or specification.

## SAFETY RULES

Do not replace factory-installed tires with tires of different specification or ply rating.

High flotation tires must be factory-installed. Do not replace standard factory-installed tires with high flotation tires.

Do not modify or alter an aerial work platform without prior written permission from the manufacturer. Mounting attachments for holding tools or other materials onto the platform, toeboards or guard rail system can increase the weight in the platform and the surface area of the platform or the load.

Do not transport tools and materials unless they are evenly distributed and can be safely handled by person(s) in the platform.

Do not place or attach overhanging loads to any part of this machine.

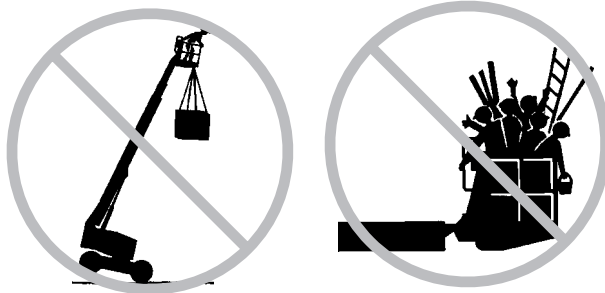

Do not place ladders or scaffolds in the platform or against any part of this machine.

Do not use the machine on a moving or mobile surface or vehicle.

Be sure all tires are in good condition, air-filled tires are properly inflated and lug nuts are properly tightened.

Do not use the machine as a crane.

Do not push the machine or other objects with the boom.

Do not contact adjacent structures with the boom.

Do not tie the boom or platform to adjacent structures.

Do not place loads outside the platform perimeter.

**Models with 750 lb / 340 kg Capacity:** Do not attach a platform rated at 750 lbs / 340 kg to machines with any other rated load. See the serial label for the maximum rated load.

## Fall Hazards

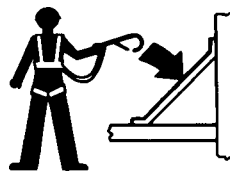

Occupants must wear a safety belt or harness in accordance with governmental regulations. Attach the lanyard to the anchor provided in the platform.

Do not sit, stand or climb on the platform guard rails. Maintain a firm footing on the platform floor at all times.



Do not climb down from the platform when raised.

Keep the platform floor clear of debris.

Lower the platform entry mid-rail or close the entry gate before operating.

## SAFETY RULES

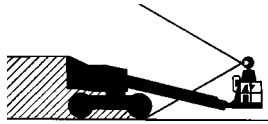
**Collision Hazards**

Be aware of limited sight distance and blind spots when driving or operating.

Be aware of the boom position and tailswing when rotating the turntable.

Check the work area for overhead obstructions or other possible hazards.

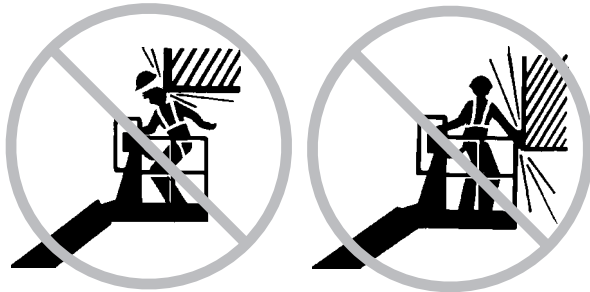

Be aware of crushing hazards when grasping the platform guard rail.

Do not lower the boom unless the area below is clear of personnel and obstructions.

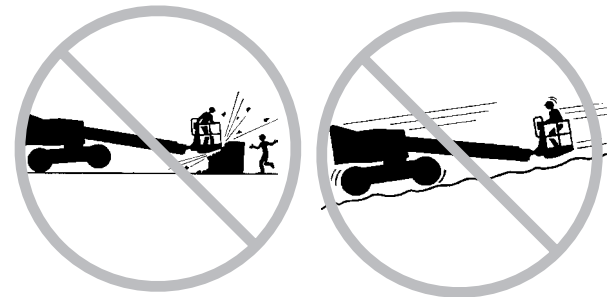

Limit travel speed according to the condition of the ground surface, congestion, slope, location of personnel, and any other factors which may cause collision.

Operators must comply with employer, job site and governmental rules regarding the use of personal protective equipment.

Observe and use color-coded direction arrows on the platform controls and drive chassis for drive and steer functions.

Do not operate a boom in the path of any crane unless the controls of the crane have been locked out and/or precautions have been taken to prevent any potential collision.

No stunt driving or horseplay while operating a machine.

**Component Damage Hazards**

Do not use any battery or charger greater than 12V to jump-start the engine.

Do not use the machine as a ground for welding.

**Explosion and Fire Hazards**

Do not start the engine if you smell or detect liquid petroleum gas (LPG), gasoline, diesel fuel or other explosive substances.

Do not refuel the machine with the engine running.

Refuel the machine and charge the battery only in an open, well-ventilated area away from sparks, flames and lighted tobacco.

Do not operate the machine in hazardous locations or locations where potentially flammable or explosive gases or particles may be present.

Do not spray ether into engines equipped with glow plugs.

---

## SAFETY RULES

### Damaged Machine Hazards

Do not use a damaged or malfunctioning machine.

Conduct a thorough pre-operation inspection of the machine and test all functions before each work shift. Immediately tag and remove from service a damaged or malfunctioning machine.

Be sure all maintenance has been performed as specified in this manual and the *Genie S-60 & Genie S-65 Service Manual*.

Be sure all decals are in place and legible.

Be sure the operator's, safety and responsibilities manuals are complete, legible and in the storage container located on the platform.

### Bodily Injury Hazard

Do not operate the machine with a hydraulic oil or air leak. An air leak or hydraulic leak can penetrate and/or burn skin.

Always operate the machine in a well-ventilated area to avoid carbon monoxide poisoning.

Improper contact with components under any cover will cause serious injury. Only trained maintenance personnel should access compartments. Access by the operator is only advised when performing a pre-operation inspection. All compartments must remain closed and secured during operation.

### Battery Safety

---

#### Burn Hazards

Batteries contain acid. Always wear protective clothing and eye wear when working with batteries.

Avoid spilling or contacting battery acid. Neutralize battery acid spills with baking soda and water.

#### Explosion Hazard

Keep sparks, flames and lighted tobacco away from batteries. Batteries emit explosive gas.

#### Electrocution Hazard

Avoid contact with electrical terminals.

#### Weld Line to Platform Safety (if equipped)

---

Read, understand and obey all warnings and instructions provided with the welding power unit.

Do not connect weld leads or cables unless the welding power unit is turned off at the platform controls.

Do not operate unless the weld cables are properly connected.

Connect the leads to the twist-lock connectors at the turntable and platform.



## SAFETY RULES

## Decal Legend

Genie product decals use symbols, color coding and signal words to identify the following:



Safety alert symbol—used to alert personnel to potential personal injury hazards. Obey all safety messages that follow this symbol to avoid possible injury or death.

**⚠ DANGER**



Red—used to indicate the presence of an imminently hazardous situation which, if not avoided, will result in death or serious injury.

**⚠ WARNING**



Orange—used to indicate the presence of a potentially hazardous situation which, if not avoided, could result in death or serious injury.

**⚠ CAUTION**



Yellow with safety alert symbol—used to indicate the presence of a potentially hazardous situation which, if not avoided, may cause minor or moderate injury.

**CAUTION**

Yellow without safety alert symbol—used to indicate the presence of a potentially hazardous situation which, if not avoided, may result in property damage.

**NOTICE**

Green—used to indicate operation or maintenance information.

# Legend

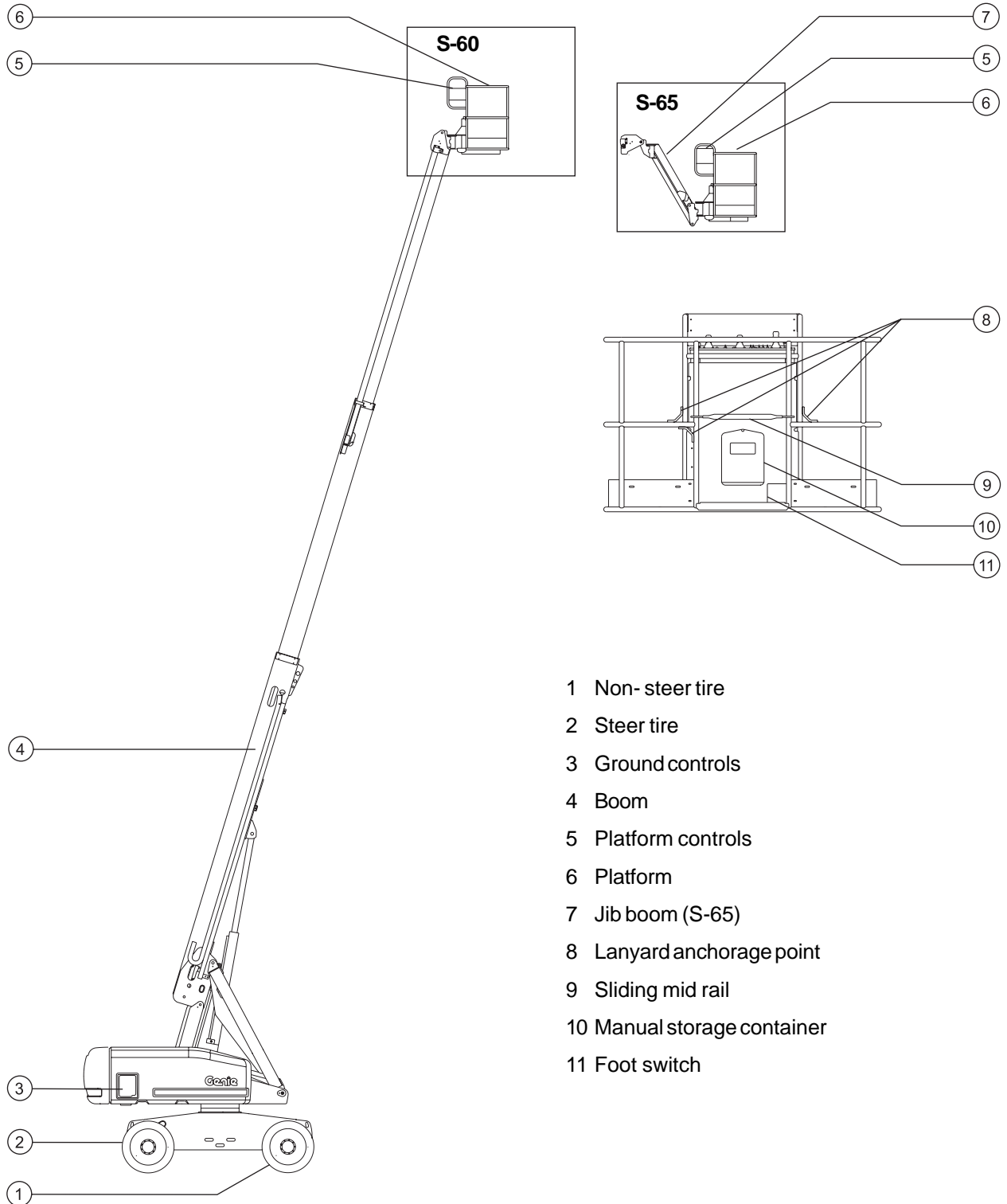

- 1 Non- steer tire
- 2 Steer tire
- 3 Ground controls
- 4 Boom
- 5 Platform controls
- 6 Platform
- 7 Jib boom (S-65)
- 8 Lanyard anchorage point
- 9 Sliding mid rail
- 10 Manual storage container
- 11 Foot switch

# Controls

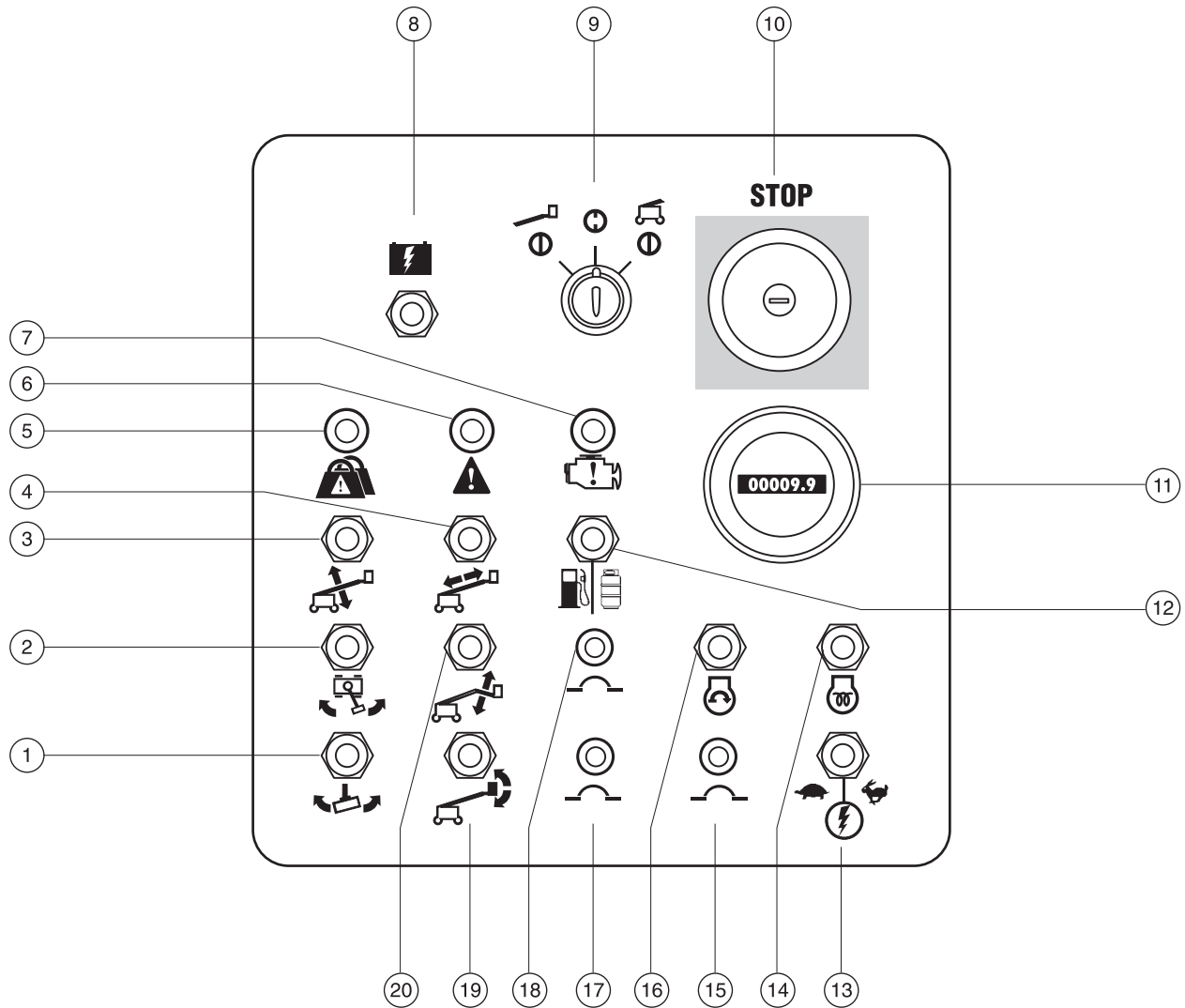

## Ground Control Panel

- |   |  |
|---|--|
| 1 Platform rotate switch                          | 11 Hour meter                                  |
| 2 Turntable rotate switch                         | 12 Gasoline/LPG models: Fuel select switch     |
| 3 Boom up/down switch                             | 13 Function enable switch                      |
| 4 Boom extend/retract switch                      | 14 Diesel models: Glow plug switch             |
| 5 Platform overload indicator light (if equipped) | 15 15A breaker for engine electrical circuits  |
| 6 Machine malfunction indicator light             | 16 Engine start switch                         |
| 7 Check engine light                              | 17 15A breaker for control electrical circuits |
| 8 Auxiliary power switch                          | 18 20A breaker for oil cooler and options      |
| 9 Key switch for platform/off/ground selection    | 19 Platform level switch                       |
| 10 Red Emergency Stop button                      | 20 S-65 only: Jib boom up/down switch          |



CONTROLS

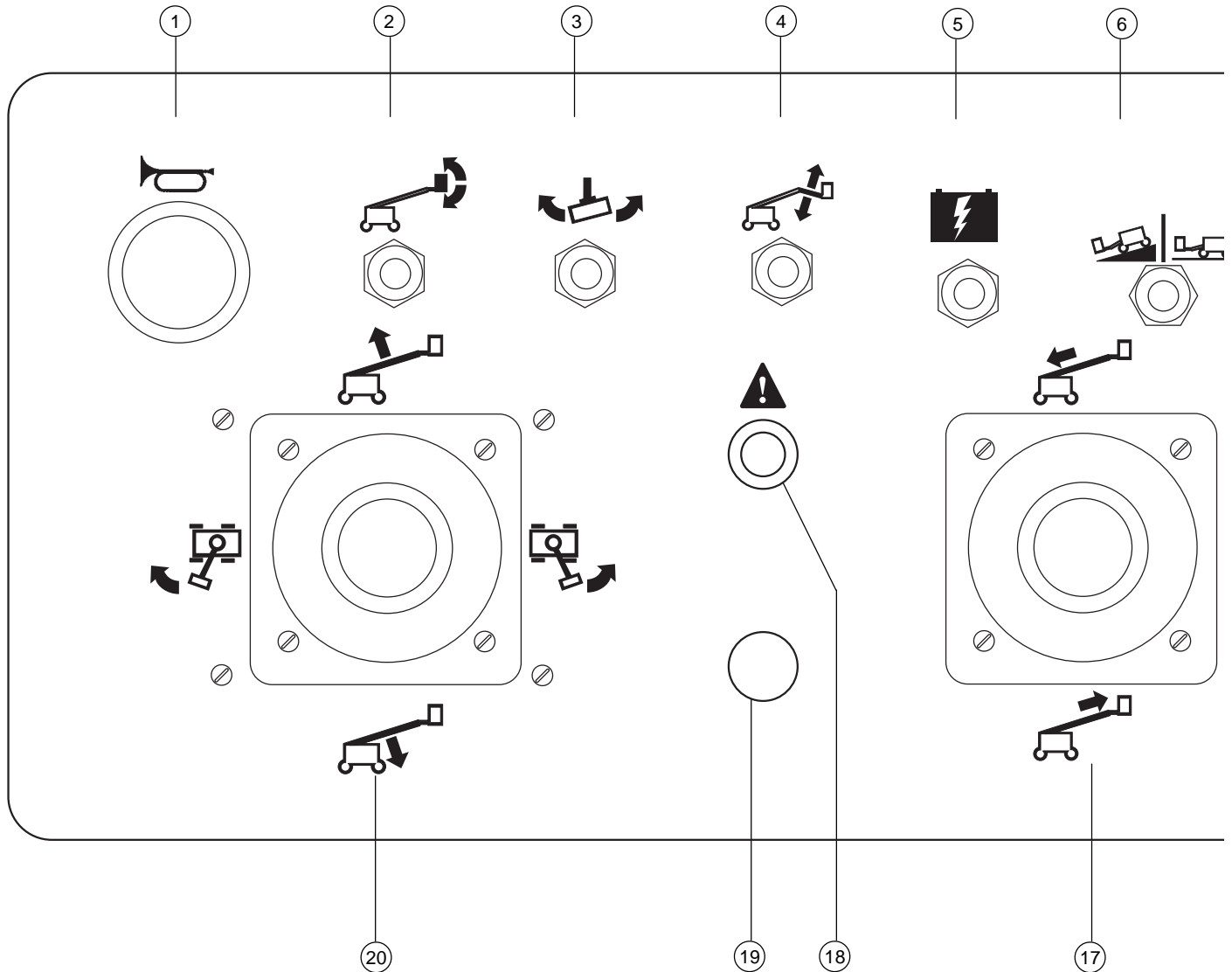

**Platform Control Panel**

- 1 Horn button
- 2 Platform level switch
- 3 Platform rotate switch
- 4 S-65 only: Jib boom up/down switch
- 5 Auxiliary power switch
- 6 Drive speed select switch
- 7 Glow plug switch
- 8 Engine start switch
- 9 Engine idle (rpm) select switch
  - Turtle: foot switch activated low idle
  - Rabbit: foot switch activated high idle
- 10 Gasoline/LPG models: Fuel select switch
- 11 Red Emergency Stop button
- 12 Foot switch
- 13 Foot switch
- 14 Foot switch
- 15 Foot switch
- 16 Foot switch
- 17 Foot switch
- 18 Foot switch
- 19 Foot switch
- 20 Foot switch

CONTROLS

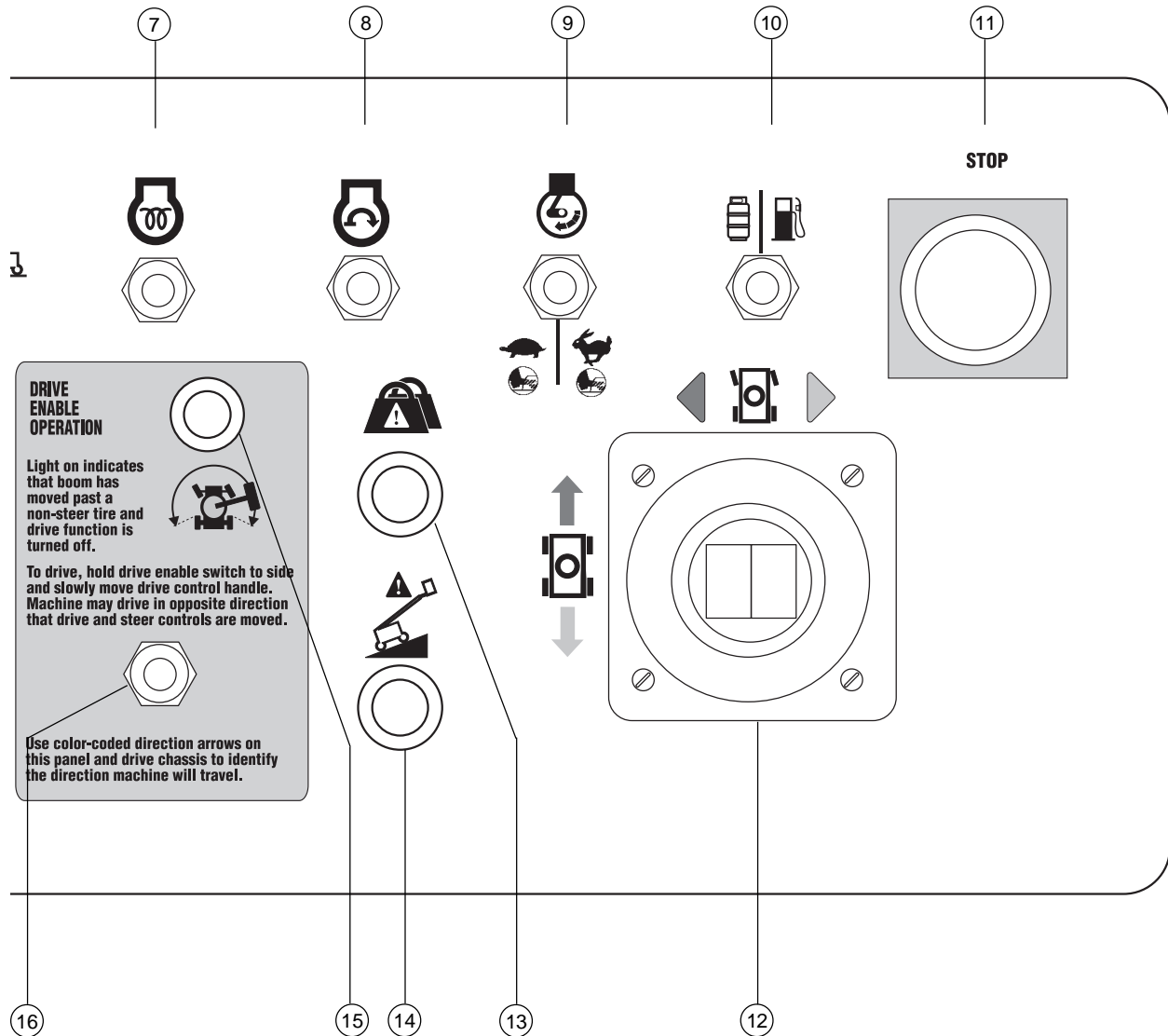

- 12 Dual axis proportional control handle for drive and steer functions  
OR Proportional control handle for drive function and thumb rocker for steer function
- 13 Platform overload indicator light (if equipped)
- 14 Machine not level indicator light (if equipped)
- 15 Drive enable indicator light

- 16 Drive enable switch
- 17 Proportional control handle for boom extend/retract
- 18 Machine malfunction indicator light
- 19 used for optional equipment
- 20 Dual axis proportional control handle for boom up/down and turntable rotate left/right functions

# Pre-operation Inspection



---

## Do Not Operate Unless:

- You learn and practice the principles of safe machine operation contained in this operator's manual.

1 Avoid hazardous situations.

**2 Always perform a pre-operation inspection.**

**Know and understand the pre-operation inspection before going on to the next section.**

3 Always perform function tests prior to use.

4 Inspect the workplace.

5 Only use the machine as it was intended.

## Fundamentals

It is the responsibility of the operator to perform a pre-operation inspection and routine maintenance.

The pre-operation inspection is a visual inspection performed by the operator prior to each work shift. The inspection is designed to discover if anything is apparently wrong with a machine before the operator performs the function tests.

The pre-operation inspection also serves to determine if routine maintenance procedures are required. Only routine maintenance items specified in this manual may be performed by the operator.

Refer to the list on the next page and check each of the items.

If damage or any unauthorized variation from factory delivered condition is discovered, the machine must be tagged and removed from service.

Repairs to the machine may only be made by a qualified service technician, according to the manufacturer's specifications. After repairs are completed, the operator must perform a pre-operation inspection again before going on to the function tests.

Scheduled maintenance inspections shall be performed by qualified service technicians, according to the manufacturer's specifications and the requirements listed in the responsibilities manual.

## PRE-OPERATION INSPECTION

## Pre-operation Inspection

---

- ❑ Be sure that the operator's, safety and responsibilities manuals are complete, legible and in the storage container located in the platform.
- ❑ Be sure that all decals are legible and in place. See Decals section.
- ❑ Check for engine oil leaks and proper oil level. Add oil if needed. See Maintenance section.
- ❑ Check for hydraulic oil leaks and proper oil level. Add oil if needed. See Maintenance section.
- ❑ Check for engine coolant leaks and proper level of coolant. Add coolant if needed. See Maintenance section.
- ❑ Check for battery fluid leaks and proper fluid level. Add distilled water if needed. See Maintenance section.
- ❑ Check for proper tire pressure. Add air if needed. See Maintenance section.

Check the following components or areas for damage, improperly installed or missing parts and unauthorized modifications:

- ❑ Electrical components, wiring and electrical cables
- ❑ Hydraulic hoses, fittings, cylinders and manifolds
- ❑ Fuel and hydraulic tanks
- ❑ Drive and turntable motors and drive hubs
- ❑ Boom wear pads
- ❑ Tires and wheels
- ❑ Engine and related components

- ❑ Limit switches and horn
- ❑ Alarms and beacons (if equipped)
- ❑ Nuts, bolts and other fasteners
- ❑ Platform entry mid-rail or gate

Check entire machine for:

- ❑ Cracks in welds or structural components
- ❑ Dents or damage to machine
- ❑ Excessive rust, corrosion or oxidation
- ❑ Be sure that all structural and other critical components are present and all associated fasteners and pins are in place and properly tightened.
- ❑ After you complete your inspection, be sure that all compartment covers are in place and latched.

# Maintenance



## Observe and Obey:

- ☑ Only routine maintenance items specified in this manual shall be performed by the operator.
- ☑ Scheduled maintenance inspections shall be completed by qualified service technicians, according to the manufacturer's specifications and the requirements specified in the responsibilities manual.

## Maintenance Symbols Legend

### NOTICE

The following symbols have been used in this manual to help communicate the intent of the instructions. When one or more of the symbols appear at the beginning of a maintenance procedure, it conveys the meaning below.



Indicates that tools will be required to perform this procedure.



Indicates that new parts will be required to perform this procedure.



Indicates that a cold engine is required before performing this procedure.

## Check the Engine Oil Level



Maintaining the proper engine oil level is essential to good engine performance and service life. Operating the machine with an improper oil level can damage engine components.

### NOTICE

Check the oil level with the engine off.

- 1 Check the oil dipstick. Add oil as needed.

### Perkins 404-22 Engine

Oil type	15W-40
Oil type - cold conditions	5W-40

### Ford LRG-425 EFI Engine (EPA Compliant)

Oil type	10W-40
Oil type - cold conditions	5W-30

### Deutz F3L 2011F Engine

Oil type	15W-40
Oil type - cold conditions	5W-30

### Ford DSG-423 Engine (EPA 2006 Compliant)

Oil type	5W-20
Oil type - cold conditions	5W-20



## MAINTENANCE

## Check the Hydraulic Oil Level



Maintaining the hydraulic oil at the proper level is essential to machine operation. Improper hydraulic oil levels can damage hydraulic components. Daily checks allow the inspector to identify changes in oil level that might indicate the presence of hydraulic system problems.

- 1 Be sure that the boom is in the stowed position, then visually inspect the sight gauge located on the side of the hydraulic oil tank. Add oil as needed.
- ⦿ Result: The hydraulic oil level should be within the top 2 inches / 5 cm of the sight gauge.
- 2 Add oil as needed.

### Hydraulic oil specifications

Hydraulic oil type	Chevron Rykon Premium MV equivalent
--------------------	--

## Check the Engine Coolant Level - Liquid Cooled Models



Maintaining the engine coolant at the proper level is essential to engine service life. Improper coolant level will affect the engine's cooling capability and damage engine components. Daily checks will allow the inspector to identify changes in coolant level that might indicate cooling system problems.

**CAUTION** Burn hazard. Beware of hot engine parts and coolant. Contact with hot engine parts and/or coolant may cause severe burns.

- 1 Check the fluid level in the coolant recovery tank. Add fluid as needed.
- ⦿ Result: The fluid level should be at the FULL mark.

**NOTICE** Do not remove the radiator cap.

## MAINTENANCE

## Check the Batteries



Proper battery condition is essential to good engine performance and operational safety. Improper fluid levels or damaged cables and connections can result in engine component damage and hazardous conditions.

**⚠ WARNING** Electrocutation hazard. Contact with hot or live circuits may result in death or serious injury. Remove all rings, watches and other jewelry.

**⚠ WARNING** Bodily injury hazard. Batteries contain acid. Avoid spilling or contacting battery acid. Neutralize battery acid spills with baking soda and water.

- 1 Put on protective clothing and eye wear.
- 2 Be sure that the battery cable connections are tight and free of corrosion.
- 3 Be sure that the battery hold-down brackets are in place and secure.
- 4 Remove the battery vent caps.
- 5 Check the battery acid level. If needed, replenish with distilled water to the bottom of the battery fill tube. Do not overfill.
- 6 Install the vent caps.

**NOTICE** Adding terminal protectors and a corrosion preventative sealant will help eliminate corrosion on the battery terminals and cables.

## Check the Tire Pressure



**⚠ DANGER** Tip-over hazard. An over-inflated tire can explode which may compromise machine stability and cause the machine to tip over.

**⚠ DANGER** Tip-over hazard. The use of temporary flat tire repair products may lead to tire failure which could compromise machine stability and cause the machine to tip over.

**⚠ WARNING** Bodily injury hazard. An over-inflated tire can explode and may cause death or serious injury.

**NOTICE** This procedure does not need to be performed on machines equipped with foam-filled tires.

- 1 Check each tire with an air pressure gauge. Add air as needed.

<b>Tire pressure</b>	70 psi	4.92 bar
<b>High flotation tire pressure</b>	60 psi	4.21 bar

## Scheduled Maintenance

Maintenance performed quarterly, annually and every two years must be completed by a person trained and qualified to perform maintenance on this machine according to the procedures found in the service manual for this machine.

Machines that have been out of service for more than three months must receive the quarterly inspection before they are put back into service.

# Function Tests



---

## Do Not Operate Unless:

- You learn and practice the principles of safe machine operation contained in this operator's manual.

- 1 Avoid hazardous situations.
- 2 Always perform a pre-operation inspection.

### **3 Always perform function tests prior to use.**

### **Know and understand the function tests before going on to the next section.**

- 4 Inspect the workplace.
- 5 Only use the machine as it was intended.

## Fundamentals

The function tests are designed to discover any malfunctions before the machine is put into service. The operator must follow the step-by-step instructions to test all machine functions.

A malfunctioning machine must never be used. If malfunctions are discovered, the machine must be tagged and removed from service. Repairs to the machine may only be made by a qualified service technician, according to the manufacturer's specifications.

After repairs are completed, the operator must perform a pre-operation inspection and function tests again before putting the machine into service.

## FUNCTION TESTS

- 1 Select a test area that is firm, level and free of obstruction.

**At the Ground Controls**

- 2 Turn the key switch to ground control.
- 3 Pull out the red Emergency Stop button to the on position.
- ⦿ Result: The beacon (if equipped) should flash.
- 4 Start the engine (see Operating Instructions section).

**Test Emergency Stop**

- 5 Push in the red Emergency Stop button to the off position.
- ⦿ Result: The engine should turn off and all functions should not operate.
- 6 Pull out the red Emergency Stop button to the on position and restart the engine.

**Test the Machine Functions**

- 7 Do not hold the function enable switch to either side. Attempt to activate each boom and platform function toggle switch. 
- ⦿ Result: All boom and platform functions should not operate.
- 8 Hold the function enable switch to either side and activate each boom and platform function toggle switch.
- ⦿ Result: All boom and platform functions should operate through a full cycle. The descent alarm (if equipped) should sound while the boom is lowering.

**Test the Tilt Sensor**

- 9 Pull out the platform red Emergency Stop button to the on position. Turn the key switch to platform control.
- 10 Open the tank side turntable cover and locate the tilt sensor next to the fuel tank. 
- 11 Press down one side of the tilt sensor.
- ⦿ Result: The alarm, located in the platform, should sound.

**Test Auxiliary Controls**

- 12 Turn the key switch to ground control and shut the engine off.
- 13 Pull out the red Emergency Stop button to the on position.
- 14 Simultaneously hold the auxiliary power switch on and activate each boom function toggle switch. 

Note: To conserve battery power, test each function through a partial cycle.

- ⦿ Result: All boom functions should operate.

## FUNCTION TESTS

**At the Platform Controls****Test Emergency Stop**

- 15 Turn the key switch to platform control and restart the engine.
- 16 Push in the platform red Emergency Stop button to the off position.
- ⊙ Result: The engine should turn off and all functions should not operate.
- 17 Pull out the red Emergency Stop button and restart the engine.

**Test the Horn**

- 18 Push the horn button.
- ⊙ Result: The service horn should sound.

**Test the Foot Switch**

- 19 Push in the platform red Emergency Stop button to the off position.
- 20 Pull out the red Emergency Stop button to the on position but do not start the engine.
- 21 Press down the foot switch and attempt to start the engine by moving the start toggle switch to either side.
- ⊙ Result: The engine should not start.
- 22 Do not press down the foot switch. Restart the engine.
- 23 Do not press down the foot switch. Test each machine function.
- ⊙ Result: The machine functions should not operate.

**Test Machine Functions**

- 24 Press down the foot switch.
- 25 Activate each machine function control handle or toggle switch.
- ⊙ Result: All boom/platform functions should operate through a full cycle.

**Test the Steering**

- 26 Press down the foot switch.
- 27 Press the thumb rocker switch on top of the drive control handle in the direction indicated by the blue triangle on the control panel OR slowly move the drive/steer control handle in the direction indicated by the blue triangle.
- ⊙ Result: The steer wheels should turn in the direction that the blue triangles point on the drive chassis.
- 28 Press the thumb rocker switch in the direction indicated by the yellow triangle on the control panel OR slowly move the drive/steer handle in the direction indicated by the yellow triangle.
- ⊙ Result: The steer wheels should turn in the direction that the yellow triangles point on the drive chassis.

## FUNCTION TESTS

**Test Drive and Braking**

- 29 Press down the foot switch.
- 30 Slowly move the drive control handle in the direction indicated by the blue arrow on the control panel until the machine begins to move, then return the handle to the center position.
- ⦿ Result: The machine should move in the direction that the blue arrow points on the drive chassis, then come to an abrupt stop.
- 31 Slowly move the drive control handle in the direction indicated by the yellow arrow on the control panel until the machine begins to move, then return the handle to the center position.
- ⦿ Result: The machine should move in the direction that the yellow arrow points on the drive chassis, then come to an abrupt stop.

Note: The brakes must be able to hold the machine on any slope it is able to climb.

**Test the Oscillating Axle (if equipped)**

- 32 Start the engine from the platform controls.
- 33 Drive the right steer tire up onto a 6 inch / 15 cm block or curb.
- ⦿ Result: The three remaining tires should stay in firm contact with the ground.
- 34 Drive the left steer tire up onto a 6 inch / 15 cm block or curb.
- ⦿ Result: The three remaining tires should stay in firm contact with the ground.
- 35 Drive both steer tires up onto a 6 inch / 15 cm block or curb.
- ⦿ Result: The non-steer tires should stay in firm contact with the ground.

**Test the Drive Enable System**

- 36 Press down the foot switch and lower the boom to the stowed position.
- 37 Rotate the turntable until the boom moves past one of the non-steer wheels.
- ⦿ Result: The drive enable indicator light should come on and remain on while the boom is anywhere in the range shown.

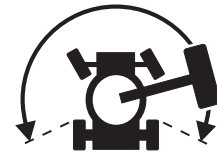

- 38 Move the drive control handle off center.
- ⦿ Result: The drive function should not operate.
- 39 Move and hold the drive enable toggle switch to either side and slowly move the drive control handle off center.
- ⦿ Result: The drive function should operate.

Note: When the drive enable system is in use, the machine may drive in the opposite direction that the drive and steer control handle is moved.

Use the color-coded direction arrows on the platform controls and the drive chassis to identify the direction of travel.

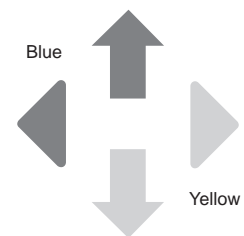

## FUNCTION TESTS

**Test Limited Drive Speed**

- 40 Press down the foot switch.
- 41 Raise the boom to just above horizontal.

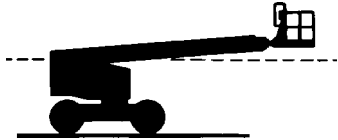

- 42 Slowly move the drive control handle to the full drive position.
- ⊙ Result: The maximum achievable drive speed with the boom raised should not exceed 1 foot / 30 cm per second.
- 43 Lower the boom to the stowed position.
- 44 Extend the boom 1 foot / 30 cm.
- 45 Slowly move the drive control handle to the full drive position.
- ⊙ Result: The maximum achievable drive speed with the boom extended should not exceed 1 foot / 30 cm per second.

If the drive speed with the boom raised or extended exceeds 1 foot / 30 cm per second, immediately tag and remove the machine from service.

**Test Auxiliary Controls**

- 46 Shut off the engine.
- 47 Pull out the red Emergency Stop button to the on position.
- 48 Press down the foot switch.
- 49 Simultaneously hold the auxiliary power switch on and activate each function control handle or toggle switch.

Note: To conserve battery power, test each function through a partial cycle.

- ⊙ Result: All boom and steer functions should operate. Drive functions should not operate with auxiliary power.

**Test the Lift/Drive Select Function (if equipped)**

- 50 Press down the foot switch.
- 51 Move the drive control handle off center.
- 52 Activate each boom function toggle switch.
- ⊙ Result: No boom functions should operate. The machine will move in the direction indicated on the control panel.

# Workplace Inspection



## Do Not Operate Unless:

- You learn and practice the principles of safe machine operation contained in this operator's manual.
  - 1 Avoid hazardous situations.
  - 2 Always perform a pre-operation inspection.
  - 3 Always perform function tests prior to use.
- 4 Inspect the workplace.**
- Know and understand the workplace inspection before going on to the next section.**
- 5 Only use the machine as it was intended.

## Fundamentals

The workplace inspection helps the operator determine if the workplace is suitable for safe machine operation. It should be performed by the operator prior to moving the machine to the workplace.

It is the operator's responsibility to read and remember the workplace hazards, then watch for and avoid them while moving, setting up and operating the machine.

## Workplace Inspection

Be aware of and avoid the following hazardous situations:

- drop-offs or holes
- bumps, floor obstructions or debris
- sloped surfaces
- unstable or slippery surfaces
- overhead obstructions and high voltage conductors
- hazardous locations
- inadequate surface support to withstand all load forces imposed by the machine
- wind and weather conditions
- the presence of unauthorized personnel
- other possible unsafe conditions



# Operating Instructions



---

## Do Not Operate Unless:

- You learn and practice the principles of safe machine operation contained in this operator's manual.
  - 1 Avoid hazardous situations.
  - 2 Always perform a pre-operation inspection.
  - 3 Always perform function tests prior to use.
  - 4 Inspect the workplace.
  - 5 Only use the machine as it was intended.**

## Fundamentals

The Operating Instructions section provides instructions for each aspect of machine operation. It is the operator's responsibility to follow all the safety rules and instructions in the operator's, safety and responsibilities manuals.

Using the machine for anything other than lifting personnel, along with their tools and materials, to an aerial work site is unsafe and dangerous.

Only trained and authorized personnel should be permitted to operate a machine. If more than one operator is expected to use a machine at different times in the same work shift, they must all be qualified operators and are all expected to follow all safety rules and instructions in the operator's, safety and responsibilities manuals. That means every new operator should perform a pre-operation inspection, function tests, and a workplace inspection before using the machine.

## OPERATING INSTRUCTIONS

**Starting the Engine**

- 1 At the ground controls, turn the key switch to the desired position.
- 2 Be sure both ground and platform control red Emergency Stop buttons are pulled out to the on position.

**Gasoline/LPG models**

- 3 Choose fuel by moving the fuel select switch to the desired position.
- 4 Move the engine start toggle switch to either side. If the engine fails to start or dies, the restart delay will disable the start switch for 3 seconds.

**Diesel models**

- 3 Move the glow plug switch to either side and hold for 3 to 5 seconds.
- 4 Move the engine start toggle switch to either side. If the engine fails to start or dies, the restart delay will disable the start switch for 3 seconds.

**All models**

If engine fails to start after 15 seconds of cranking, determine the cause and repair any malfunction. Wait 60 seconds before trying to start again.

In cold conditions, 20°F / -6°C and below, warm the engine for 5 minutes before operating to prevent hydraulic system damage.

In extreme cold conditions, 0°F / -18°C and below, machines should be equipped with optional cold start kits. Attempting to start the engine when temperatures are below 0°F / -18°C may require the use of a booster battery.

Gasoline/LPG models: In cold conditions, 20°F / -6°C and below, the machine should be started on gasoline and warmed for 2 minutes, then switched to LPG. Warm engines can be started on LPG.

**Emergency Stop**

Push in either the ground or platform red Emergency Stop button to the off position to stop all functions and turn the engine off.

Repair any function that operates when the red Emergency Stop button is pushed in.

Selecting and operating the ground controls will override the platform red Emergency Stop button.

**Auxiliary Controls**

Use auxiliary power if the primary power source (engine) fails.

- 1 Turn the key switch to ground or platform control.
- 2 Pull out the red Emergency Stop button to the on position.
- 3 Press down the foot switch when operating the auxiliary controls from the platform.
- 4 Simultaneously hold the auxiliary power switch and activate desired function.



The drive function will not operate with auxiliary power.

## OPERATING INSTRUCTIONS

## Operation from Ground

- 1 Turn the key switch to ground control.
- 2 Pull out the red Emergency Stop button to the on position.
- 3 Gasoline/LPG models: Choose fuel by moving the fuel select switch to the desired position.
- 4 Start the engine.

### To Position Platform

- 1 Hold the function enable switch to either side.
- 2 Move the appropriate toggle switch according to the markings on the control panel.



Drive and steer functions are not available from the ground controls.

## Operation from Platform

- 1 Turn the key switch to platform control.
- 2 Pull out both ground and platform red Emergency Stop buttons to the on position.
- 3 Gasoline/LPG models: Choose fuel by moving the fuel select switch to the desired position.
- 4 Start the engine. Do not press down the foot switch when starting the engine.

### To Position Platform

- 1 Press down the foot switch.
- 2 Slowly move the appropriate function control handle or toggle switch according to the markings on the control panel.

### To Steer

- 1 Press down the foot switch.
- 2 Turn the steer wheels with the thumb rocker switch located on top of the drive control handle.

Use the color-coded direction triangles on the platform controls and the drive chassis to identify the direction the wheels will turn.

### To Drive

- 1 Press down the foot switch.
- 2 Increase speed: Slowly move the drive control handle off center.  
Decrease speed: Slowly move the drive control handle toward center.  
Stop: Return the drive control handle to center or release the foot switch.

Use the color-coded direction arrows on the platform controls and the drive chassis to identify the direction the machine will travel.

Machine travel speed is restricted when the boom is raised or extended.

## OPERATING INSTRUCTIONS

**Driving on a slope**

Determine the uphill, downhill and side slope ratings for the machine and determine the slope grade.



Maximum slope rating,  
counterweight uphill  
(gradeability):  
2WD: 30% (17°)  
4WD: 45% (24°)



Maximum slope rating,  
counterweight downhill:  
2WD: 10% (6°)  
4WD: 30% (17°)



Maximum side slope rating:  
25% (14°)

Note: Slope rating is subject to ground conditions and adequate traction. The term gradeability applies to the counterweight uphill configuration only.

Be sure the boom is below horizontal and the platform is between the non-steer wheels.

Move the drive speed select switch to machine on incline symbol.

**To determine the slope grade:**

Measure the slope with a digital inclinometer OR use the following procedure.

You will need:

- carpenter's level
- straight piece of wood, at least 3 feet / 1 m long
- tape measure

Lay the piece of wood on the slope.

At the downhill end, lay the level on the top edge of the piece of wood and lift the end until the piece of wood is level.

While holding the piece of wood level, measure the vertical distance from the bottom of the piece of wood to the ground.

Divide the tape measure distance (rise) by the length of the piece of wood (run) and multiply by 100.

Example:

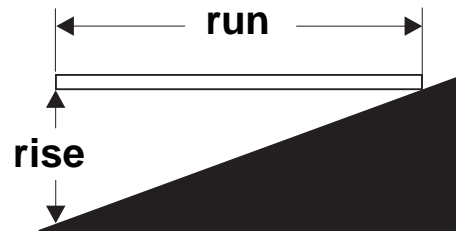

Piece of wood = 144 inches (3.6 m)

Run = 144 inches (3.6 m)

Rise = 12 inches (0.3 m)

$12 \text{ in} \div 144 \text{ in} = 0.083 \times 100 = 8.3\% \text{ grade}$

$0.3 \text{ m} \div 3.6 \text{ m} = 0.083 \times 100 = 8.3\% \text{ grade}$

If the slope exceeds the maximum uphill, downhill or side slope rating, then the machine must be winched or transported up or down the slope. See Transport and Lifting section.

## OPERATING INSTRUCTIONS

**Drive Enable**

Light on indicates that the boom has moved just past either non-steer wheel and drive function has been interrupted.



To drive, hold the drive enable switch to either side and slowly move the drive control handle off center.

Be aware that the machine may move in the opposite direction that the drive and steer controls are moved.

Always use the color-coded direction arrows on the platform controls and the drive chassis to identify the direction the machine will travel.

**Drive Speed Select**

- Machine on incline symbol: Low range operation for inclines
- Machine on level surface symbol: High range operation for maximum drive speed

**Engine Idle Select (rpm)**

When the foot switch is not pressed, the engine will idle at the lowest rpm.



- Turtle symbol: Foot switch activated low idle
- Rabbit symbol: Foot switch activated high idle

**Generator (if equipped)**

To start the generator, move the generator toggle switch to the on position.

Plug a power tool into the power to platform GFCI outlet.

To turn off the generator, move the generator toggle switch to the off position.

Note: Machine functions will not operate while the generator is running and the foot switch is not pressed down. When the foot switch is pressed down, the generator will turn off and the machine functions will operate.

**Platform Overload Indicator Light (if equipped)**

Light flashing indicates the platform is overloaded and no functions will operate.

Remove weight from the platform until the light goes off.

**Machine Not Level Indicator Light (if equipped)**

Light on indicates machine is not level. The tilt alarm will be sounding when this light is on. Move the machine to a firm level surface.

## OPERATING INSTRUCTIONS

## Machine Malfunction Indicator Light



Light on indicates all functions have stopped.

- 1 Push in and then pull out the red Emergency Stop button.
- 2 Lower and retract the boom.
- 3 Tag the machine and remove from service. Functions will not operate.

## Check Engine Light



Light on and engine stopped: Tag the machine and remove from service.

Light on and engine still running: Contact service personnel within 24 hours.

## Fall Protection

Personal fall protection equipment (PFPE) is required when operating this machine.

All PFPE must comply with applicable governmental regulations, and must be inspected and used in accordance with the PFPE manufacturer's instructions.

## After Each Use

- 1 Select a safe parking location—firm level surface, clear of obstruction and traffic.
- 2 Retract and lower the boom to the stowed position.
- 3 Rotate the turntable so that the boom is between the non-steer wheels.
- 4 Turn the key switch to the off position and remove the key to secure from unauthorized use.
- 5 Chock the wheels.

# Transport and Lifting Instructions



## Observe and Obey:

- ☑ Genie Industries provides this securement information as a recommendation. Drivers are solely responsible for making sure machines are properly secured and the correct trailer is selected pursuant to US Department of Transportation regulations, other localized regulations, and their company policy.
- ☑ Genie customers needing to containerize any lift or Genie product should source a qualified freight forwarder with expertise in preparing, loading and securing construction and lifting equipment for international shipment.
- ☑ Only qualified aerial lift operators should move the machine on or off the truck.
- ☑ The transport vehicle must be parked on a level surface.
- ☑ The transport vehicle must be secured to prevent rolling while the machine is being loaded.
- ☑ Be sure the vehicle capacity, loading surfaces and chains or straps are sufficient to withstand the machine weight. Genie lifts are very heavy relative to their size. See the serial label for the machine weight. See the Decals section for the serial label location.

- ☑ Be sure the turntable is secured with the turntable rotation lock before transporting. Be sure to unlock the turntable for operation.
- ☑ If the slope of the transport vehicle bed exceeds the uphill or downhill maximum slope rating, the machine must be loaded and unloaded using a winch as described. See the Specifications section for the slope ratings.

## Free-wheel Configuration for Winching

Chock the wheels to prevent the machine from rolling.

2WD models: Release the non-steer wheel brakes by turning over the drive hub disconnect caps.

4WD models: Release the wheel brakes by turning over all four drive hub disconnect caps.

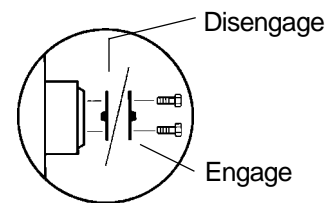

Be sure the winch line is properly secured to the drive chassis tie points and the path is clear of all obstructions.

Reverse the procedures described to re-engage the brakes.

Note: The pump free-wheel valve should always remain closed.

TRANSPORT AND LIFTING INSTRUCTIONS

### Securing to Truck or Trailer for Transit

Always use the turntable rotation lock pin each time the machine is transported.

Turn the key switch to the off position and remove the key before transporting.

Inspect the entire machine for loose or unsecured items.

#### Securing the Chassis

Use chains of ample load capacity.

Use a minimum of 5 chains.

Adjust the rigging to prevent damage to the chains.

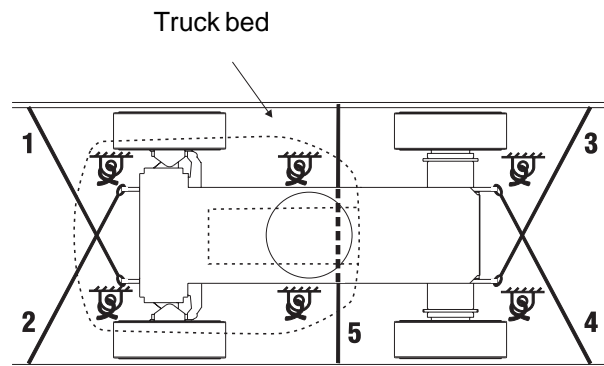

#### Securing the Platform - S-60

Place a block under the platform rotator. Do not allow the block to contact the platform cylinder.

Secure the platform with a nylon strap placed through the lower platform support. Do not use excessive downward force when securing the boom section.

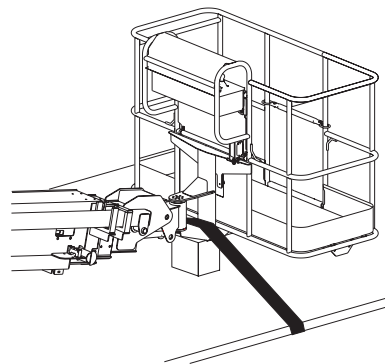

#### Securing the Platform - S-65

Place a block under the platform rotator. Do not allow the block to contact the platform cylinder.

Secure the platform with a nylon strap placed through the lower platform support. Do not use excessive downward force when securing the boom section.

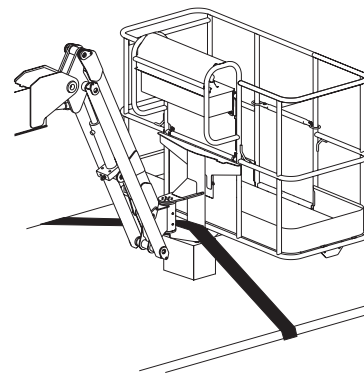



TRANSPORT AND LIFTING INSTRUCTIONS



**Observe and Obey:**

- ☑ Only qualified riggers should rig and lift the machine.
- ☑ Be sure the crane capacity, loading surfaces and straps or lines are sufficient to withstand the machine weight. See the serial label for the machine weight.

**Lifting Instructions**

Fully lower and retract the boom. Move the jib boom parallel with the ground. Remove all loose items on the machine.

Use the turntable rotation lock to secure the turntable.

Determine the center of gravity of your machine using the table and the picture on this page.

Attach the rigging only to the designated lifting points on the machine. There are two lifting points on the chassis and two on the turntable.

Adjust the rigging to prevent damage to the machine and to keep the machine level.

	X Axis	Y Axis
<b>S-60</b>	4.13 ft 1.25 m	50.6 in 1.28 m
<b>S-65</b>	4.18 ft 1.27 m	51.5 in 1.30 m

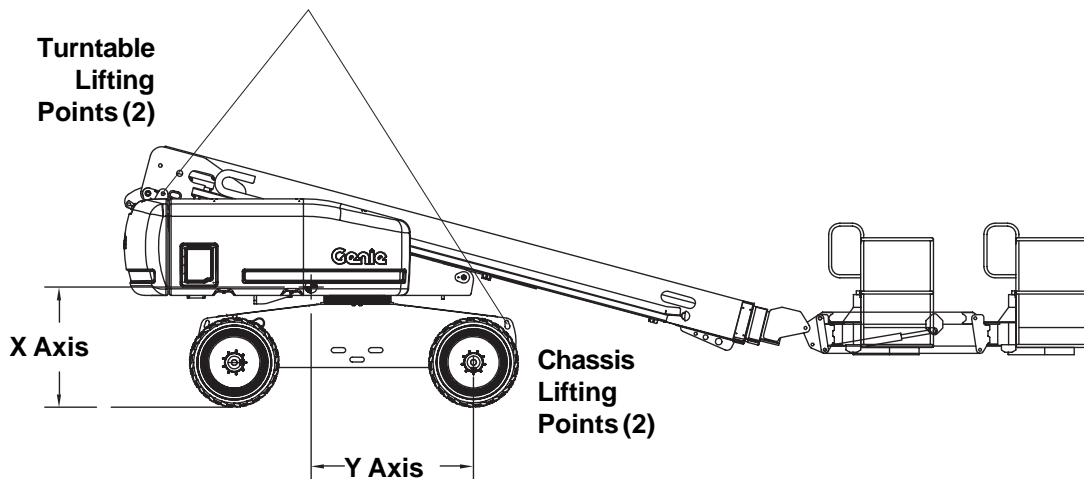

# Decals

## Inspection for Decals with Words

Determine whether the decals on your machine have words or symbols. Use the appropriate inspection to verify that all decals are legible and in place.

Part No.	Decal Description	Quantity
25994	Caution - Component Damage Hazard	1
27204	Arrow - Blue	1
27205	Arrow - Yellow	1
27206	Triangle - Blue	2
27207	Triangle - Yellow	2
27564	Danger - Electrocutation Hazard	2
28158	Label - Unleaded	1
28159	Label - Diesel	1
28160	Label - Liquid Petroleum Gas (option)	1
28161	Warning - Crushing Hazard	4
28164	Notice - Hazardous Materials	1
28165	Notice - Foot Switch	1
28171	Label - No Smoking	1
28174	Label - Power to Platform, 230V	2
28175	Caution - Compartment Access	1
28176	Notice - Missing Manuals	1
28177	Warning - Platform Rotate	2
28181	Warning - No Step or Ride	1
28235	Label - Power to Platform, 115V	2
28236	Warning - Failure To Read . . .	1
30080*	Notice - Maximum Load, 500 lbs / 227 kg	1
31060	Danger - Tip-over Hazard, Interlock	3
32728	Label - Generator (option)	1
33952	Danger - Tilt-Alarm	1
40434	Label - Lanyard Anchorage	3
43594*	Notice - Maximum Load, 750 lbs / 340 kg	1
44981	Label - Air Line to Platform	2
44986	Notice - Maximum Manual Force, 90 lbs / 400 N, CE and AUS	1

Part No.	Decal Description	Quantity
52966	Cosmetic - 4 x 2	1
52967	Cosmetic - 4 x 4	1
62076	Cosmetic - Genie S-60	1
62077	Cosmetic - S-60	1
62078	Cosmetic - Genie S-65	1
62079	Cosmetic - S-65	1
82366	Label - Chevron Rykon	1
82455	Ground Control Panel	1
82456	Platform Control Panel	1
82549	Label - Wheel Load, S-60	4
82550	Label - Wheel Load, S-65	4
82644	Notice - Perkins Diesel Engine Specs	1
82677	Danger/Notice - Tire Specifications	4
82678	Danger/Notice - High Flotation Tire Specifications	4
82686	Danger - Tip-over, Hi-Capacity	1
97548	Notice - Deutz Diesel Engine Specs	1
97571	Notice - Ford Engine Specs (LRG-425)	1
97602	Warning - Explosion Hazard	1
97815	Label - Lower Midrail	1
97887	Notice - Max Side Force, 150 lbs/667N, ANSI and CSA	1
97890	Danger - General Safety	1
114099	Transport Diagram	2
114169	Notice - Ford Engine Specs (DSG-423)	1
114277	Label - Belt Routing (DSG-423)	1
1000014	Notice - Operating Instructions	2

\*Please reference the Specifications section or the chart on page 2 to determine the capacity of your machine.

DECALS

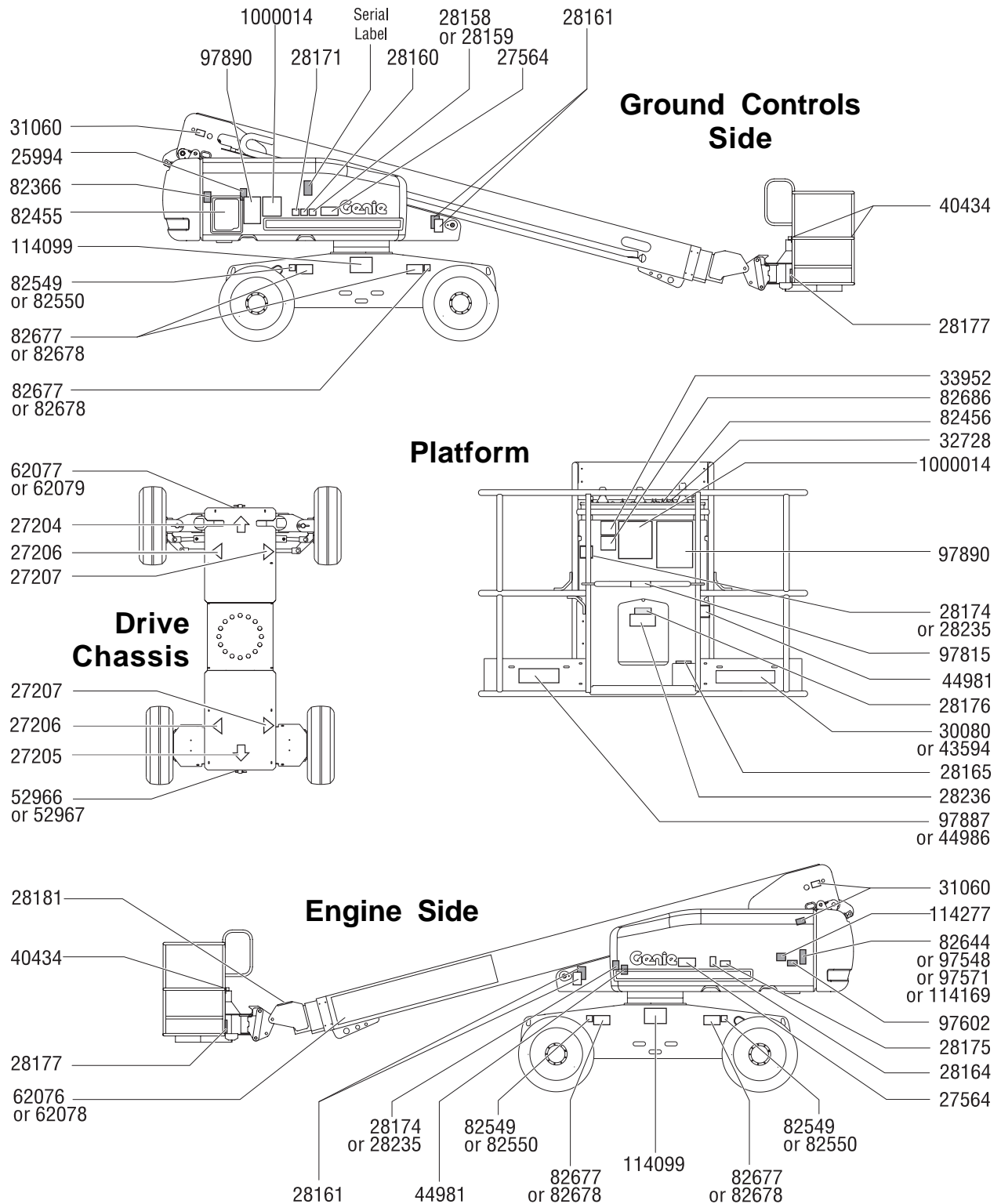

## DECALS

## Inspection for Decals with Symbols

Determine whether the decals on your machine have words or symbols. Use the appropriate inspection to verify that all decals are legible and in place.

Part No.	Decal Description	Quantity
27204	Arrow - Blue	1
27205	Arrow - Yellow	1
27206	Triangle - Blue	2
27207	Triangle - Yellow	2
28158	Label - Unleaded	1
28159	Label - Diesel	1
28160	Label - Liquid Petroleum Gas	1
28171	Label - No Smoking	1
28174	Label - Power to Platform, 230V	2
28235	Label - Power to Platform, 115V	2
32728	Label - Generator (option)	1
40434	Label - Lanyard Anchorage	3
44981	Label - Air Line to Platform (option)	2
52966	Cosmetic - 4 x 2	1
52967	Cosmetic - 4 x 4	1
62076	Cosmetic - Genie S-60	1
62077	Cosmetic - S-60	1
62078	Cosmetic - Genie S-65	1
62079	Cosmetic - S-65	1
82472	Warning - Crushing Hazard	4
82473	Caution - Compartment Access	1

Part No.	Decal Description	Quantity
82487	Notice - Operating Instructions	2
82455	Ground Control Panel	1
82456	Platform Control Panel	1
82544	Danger - Electrocuting Hazard	2
82545*	Notice - Maximum Load, 227 kg	1
82547*	Notice - Maximum Load, 340 kg	1
82548	Warning - Platform Rotate	2
82549	Label - Wheel Load, S-60	4
82550	Label - Wheel Load, S-65	4
82551	Label - Tire Pressure	4
82552	Label - Hi-Flotation Tire Pressure	4
82602	Danger - Max Manual Force, 667 N, ANSI	1
82604	Danger - Max Manual Force, 400 N, CE	1
82646	Label - Drive Enable Patch	1
82924	Caution - Component Damage	1
97815	Label - Lower Midrail	1
114277	Label - Belt Routing (DSG-423)	1
114099	Transport Diagram	2

\*Please reference the Specifications section or the chart on page 2 to determine the capacity of your machine.

DECALS

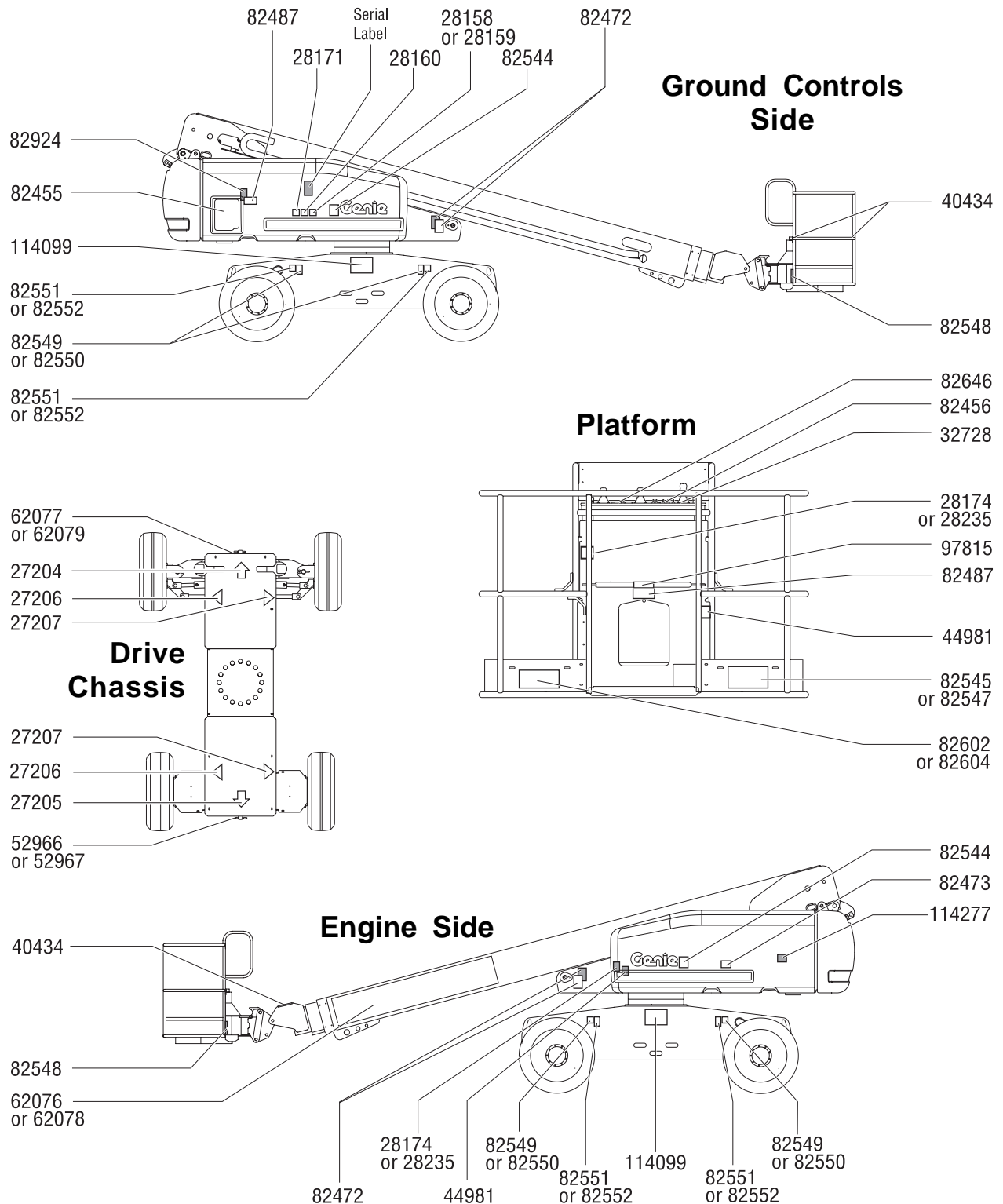

# Specifications

Model	S-60	
Height, working maximum	66 ft	20.11 m
Height, platform maximum	60 ft	18.3 m
Height, stowed maximum	8 ft 11 in	2.72 m
Horizontal reach maximum	50 ft 10 in	15.5 m
Width	8 ft 2 in	2.49 m
Length, stowed	27 ft 11 in	8.5 m
Maximum load capacity	500 lb	227 kg
Maximum load capacity with proper counterweight configuration	750 lb	340 kg
Maximum wind speed	28 mph	12.5 m/s
Wheelbase	8 ft 2 in	2.49 m
Turning radius (outside)	18 ft 2 in	5.5 m
Turning radius (inside)	7 ft 9 in	2.4 m
Turntable rotation (degrees)	continuous	
Turntable tailswing	4 ft	1.22 m
<b>Drive speeds</b>		
Drive speed, stowed, 2WD	4.0 mph 36 ft/6.2 sec	6.4 km/h 11 m/6.2 sec
Drive speed, stowed, 4WD	3.0 mph 39 ft/7.8 sec	4.8 km/h 10.4 m/7.8 sec
Drive speed, raised or extended	0.7 mph 40 ft/40 sec	1.1 km/h 10.3 m/40 sec
Airborne noise emissions Maximum sound level at normal operating workstations (A-weighted)	105 dB	
Ground clearance, center	14 in	36 cm
Ground clearance, axle	13 in	33 cm
Controls	12V DC proportional	
Weight (Machine weights vary with option configurations)	See Serial Label	

Platform dimensions, 6 foot (length x width)	72 in x 30 in 1.8 m x 76 cm	
Platform dimensions, 8 foot (length x width)	96 in x 36 in 2.4 m x 91 cm	
Platform leveling	self-leveling	
Platform rotation	160°	
AC outlet in platform	standard	
Hydraulic pressure, maximum	3000 psi	207 bar
Boom functions		
System voltage	12V	
Tire size	355/55D 625	
High flotation tire size	41/18LL x 22.5, 14 ply	

### Maximum slope rating, stowed position, 2WD

Counterweight uphill	30% / 17°	
Counterweight downhill	10% / 6°	
Side slope	25% / 14°	

### Maximum slope rating, stowed position, 4WD

Counterweight uphill	45% / 24°	
Counterweight downhill	30% / 17°	
Side slope	25% / 14°	

Note: Slope rating is subject to ground conditions and adequate traction.

Fuel tank capacity	40 gallons	151 liters
--------------------	------------	------------

### Floor loading information

Tire load, maximum	10800 lbs	4899 kg
Tire contact pressure	70 psi	4.92 kg/cm <sup>2</sup> 483 kPa
Occupied floor pressure	240 psf	1172 kg/m <sup>2</sup> 11.49 kPa

Note: Floor loading information is approximate and does not incorporate different option configurations. It should be used only with adequate safety factors.

Continuous improvement of our products is a Genie policy. Product specifications are subject to change without notice or obligation.



SPECIFICATIONS

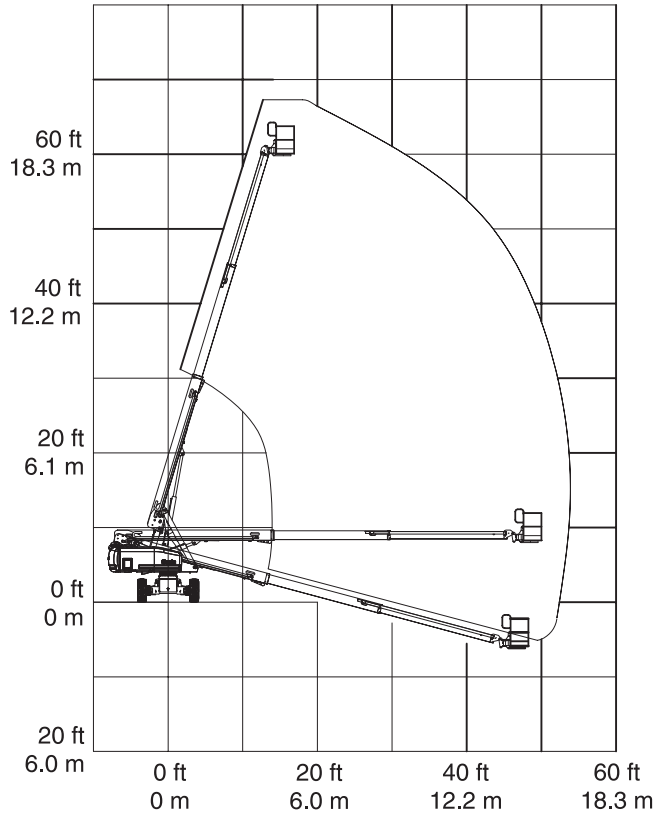

## SPECIFICATIONS

<b>Model</b>	<b>S-65</b>	
Height, working maximum	71 ft	21.6 m
Height, platform maximum	65 ft	19.8 m
Height, stowed maximum	8 ft 11 in	2.72 m
Horizontal reach maximum	56 ft 2 in	17.1 m
Width	8 ft 2 in	2.49 m
Length, stowed	31 ft 2 in	9.5 m
Maximum load capacity	500 lb	227 kg
Maximum wind speed	28 mph	12.5 m/s
Wheelbase	8 ft 2 in	2.48 m
Turning radius (outside)	18 ft 2 in	5.5 m
Turning radius (inside)	7 ft 9 in	2.4 m
Turntable rotation (degrees)	continuous	
Turntable tailswing	4 ft	1.22 m
<b>Drive speeds</b>		
Drive speed, stowed, 2WD	4.0 mph 36 ft/6.2 sec	6.4 km/h 11 m/6.2 sec
Drive speed, stowed, 4WD	3.0 mph 39 ft/7.8 sec	4.8 km/h 10.4 m/7.8 sec
Drive speed, raised or extended	0.7 mph 40 ft/40 sec	1.1 km/h 10.3 m/40 sec
Airborne noise emissions	105 dB	
Maximum sound level at normal operating workstations (A-weighted)		
Ground clearance, center	14 in	36 cm
Ground clearance, axle	13 in	33 cm
Controls	12V DC proportional	
Weight	See Serial Label (Machine weights vary with option configurations)	

Platform dimensions, 6 foot (length x width)	72 in x 30 in 1.8 m x 76 cm	
Platform dimensions, 8 foot (length x width)	96 in x 36 in 2.4 m x 91 cm	
Platform leveling	self-leveling	
Platform rotation	160°	
AC outlet in platform	standard	
Hydraulic pressure, maximum	2900 psi	204 bar
Boom functions		
System voltage	12V	
Tire size	355/55D 625	
High flotation tire size	41/18LL x 22.5, 14 ply	

**Maximum slope rating, stowed position, 2WD**

Counterweight uphill	30% / 17°	
Counterweight downhill	10% / 6°	
Side slope	25% / 14°	

**Maximum slope rating, stowed position, 4WD**

Counterweight uphill	45% / 24°	
Counterweight downhill	30% / 17°	
Side slope	25% / 14°	

Note: Slope rating is subject to ground conditions and adequate traction.

Fuel tank capacity	40 gallons	151 liters
--------------------	------------	------------

**Floor loading information**

Tire load, maximum	11600 lbs	5262 kg
Tire contact pressure	70 psi	4.92 kg/cm <sup>2</sup> 483 kPa
Occupied floor pressure	272 psf	1328 kg/m <sup>2</sup> 13.03 kPa

Note: Floor loading information is approximate and does not incorporate different option configurations. It should be used only with adequate safety factors.

Continuous improvement of our products is a Genie policy. Product specifications are subject to change without notice or obligation.





SPECIFICATIONS

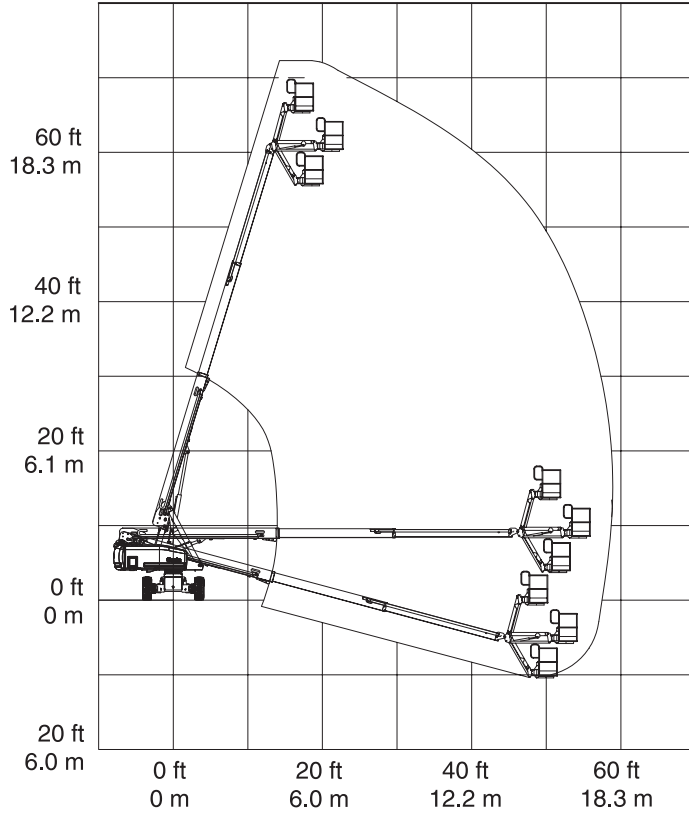

# California Proposition 65

# WARNING

The exhaust from this product contains chemicals known to the State of California to cause cancer, birth defects or other reproductive harm.

**Genie Scandinavia****Phone** +46 31 575100**Fax** +46 31 579020**Genie France****Phone** +33 (0)2 37 26 09 99**Fax** +33 (0)2 37 26 09 98**Genie Iberica****Phone** +34 93 579 5042**Fax** +34 93 579 5059**Genie Germany****Phone** +49 (0)4202 88520**Fax** +49 (0)4202 8852-20**Genie U.K.****Phone** +44 (0)1476 584333**Fax** +44 (0)1476 584334**Genie Mexico City****Phone** +52 55 5666 5242**Fax** +52 55 5666 3241**Genie North America****Phone** 425.881.1800**Toll Free** USA and Canada  
800.536.1800**Fax** 425.883.3475**Genie Australia Pty Ltd.****Phone** +61 7 3375 1660**Fax** +61 7 3375 1002**Genie China****Phone** +86 21 53852570**Fax** +86 21 53852569**Genie Malaysia****Phone** +65 98 480 775**Fax** +65 67 533 544**Genie Japan****Phone** +81 3 3453 6082**Fax** +81 3 3453 6083**Genie Korea****Phone** +82 25 587 267**Fax** +82 25 583 910**Genie Brasil****Phone** +55 11 41 665 755**Fax** +55 11 41 665 754**Genie Holland****Phone** +31 183 581 102**Fax** +31 183 581 566

Distributed By: