



Operator's Manual

Serial Number Range

S[®]-60 XC[™]

from S60XCH-45001
from S65XCM-101

S[®]-65 XC[™]

S[®]-60 HF

S[®]-65 HF

S[®]-60 TRAX[™]

S[®]-65 TRAX[™]

CE

with
Maintenance
Information

Original Instructions
First Edition
Third Printing
Part No. 1286582GT

Contents

Introduction	1
Symbol and Hazard Pictorials Definitions.....	5
General Safety	7
Personal Safety.....	10
Work Area Safety.....	11
Legend	21
Controls.....	22
Inspections.....	30
Operating Instructions.....	44
Transport and Lifting Instructions	58
Maintenance	61
Specifications.....	64

Copyright © 2018 by Terex Corporation

First Edition:, Third Edition June 2019

Genie and "S" are registered trademarks of Terex South Dakota, Inc. in the U.S.A. and many other countries.

"XC" and "TraX" are trademarks of Terex South Dakota, Inc.

 Complies with EC Directive 2006/42/EC
See EC Declaration of Conformity



Introduction

About this manual

Genie appreciates your choice of our machine for your application. Our number one priority is user safety, which is best achieved by our joint efforts. This book is an operation and daily maintenance manual for the user or operator of a Genie machine.

This manual should be considered a permanent part of your machine and should remain with the machine at all times. If you have any questions, contact Genie.

Product Identification

The machine serial number is located on the serial label.

Serial label
(located under cover)

Serial number stamped on
chassis

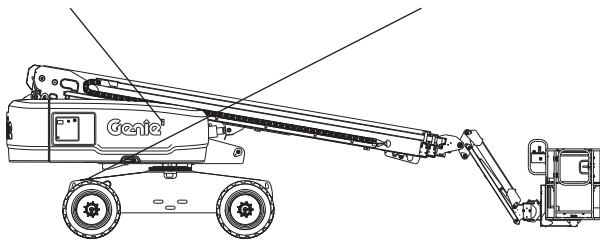

Intended Use and Familiarization Guide

The intended use of this machine is to lift personnel, including tools, and materials to an aerial work site. Before operating the machine, it's the operator's responsibility to read and understand this familiarization guide.

- Each person must be trained to operate a MEWP.
- Familiarization with the MEWP must be given to each person who is authorized, competent and trained.
- Only trained and authorized personnel should be permitted to operate the machine.
- The operator is responsible to read, understand, and obey the manufacturer's instructions and safety rules provided in the Operator's Manual.
- The Operator's Manual is located in the manual storage container, at the platform.
- For specific product applications, see **Contacting The Manufacturer** on the next page.

Introduction

Platform controls symbology and related machine movement:

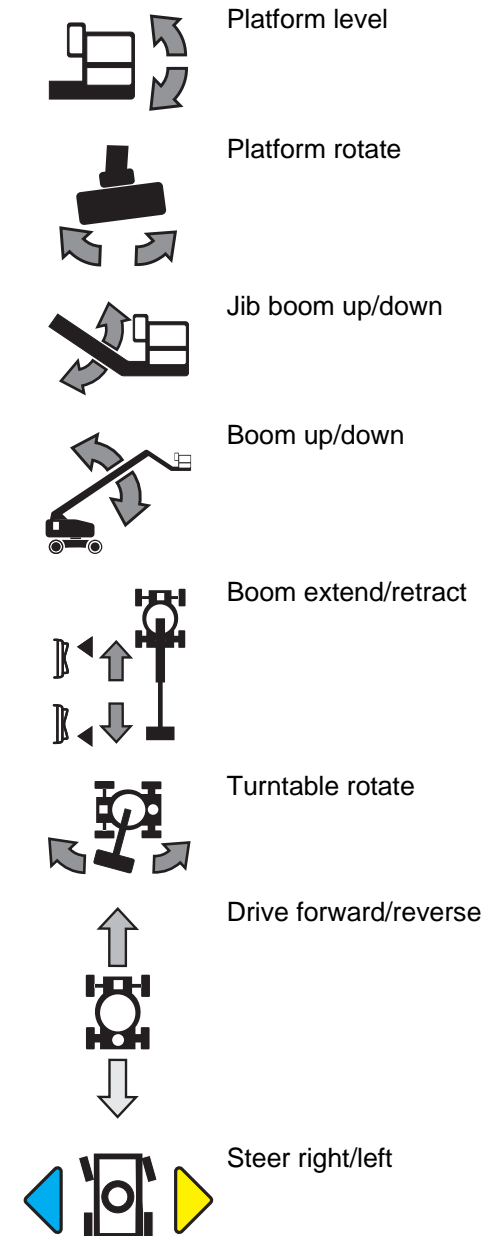

Ground controls symbology and related machine movement:

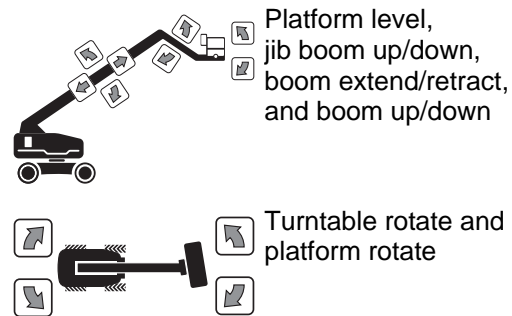

Sequential functions and movement:

- Drive and steer.

Interlocked functions:

- Elevated drive speed.
- Elevated drive in an off-level condition.
- Drive enable when the boom is rotated past the non-steer wheels, or non-steer tracks.
- All platform and ground controls.

Limitations of use:

- The intended use of this machine is to lift personnel, including tools, and materials to an aerial work site.
- Do not elevate the platform unless the machine is on firm level ground.

Stability enhancing means:

- Foam filled tires
- Tracks

Restricted operating envelope:

- 454 kg platform capacity.

Introduction

Bulletin Distribution and Compliance

Safety of product users is of paramount importance to Genie. Various bulletins are used by Genie to communicate important safety and product information to dealers and machine owners.

The information contained in the bulletins is tied to specific machines using the machine model and serial number.

Distribution of bulletins is based on the most current owner on record along with their associated dealer, so it is important to register your machine and keep your contact information up to date.

To ensure safety of personnel and the reliable continued operation of your machine, be sure to comply with the action indicated in a respective bulletin.

To view any open bulletins for your machine, visit us on the web at www.genielift.com.

Contacting the Manufacturer

At times it may be necessary to contact Genie. When you do, be ready to supply the model number and serial number of your machine, along with your name and contact information. At minimum, Genie should be contacted for:

Accident reporting

Questions regarding product applications and safety

Standards and regulatory compliance information

Current owner updates, such as changes in machine ownership or changes in your contact information. See Transfer of Ownership, below.

Transfer of Machine Ownership

Taking a few minutes to update owner information will ensure that you receive important safety, maintenance and operating information that applies to your machine.

Please register your machine by visiting us on the web at www.genielift.com or by calling us toll free at 1-800-536-1800.

Introduction



Danger

Failure to obey the instructions and safety rules in this manual will result in death or serious injury.

Do Not Operate Unless:

- ☑ You learn and practice the principles of safe machine operation contained in this operator's manual.
 - 1 **Avoid hazardous situations.**

Know and understand the safety rules before going on to the next section.

 - 2 Always perform a pre-operation inspection.
 - 3 Always perform function tests prior to use.
 - 4 Inspect the workplace.
 - 5 Only use the machine as it was intended.
- ☑ You read, understand and obey the manufacturer's instructions and safety rules—safety and operator's manuals and machine decals.
- ☑ You read, understand and obey employer's safety rules and worksite regulations.
- ☑ You read, understand and obey all applicable governmental regulations.
- ☑ You are properly trained to safely operate the machine.

Safety Sign Maintenance

Replace any missing or damaged safety signs. Keep operator safety in mind at all times. Use mild soap and water to clean safety signs. Do not use solvent-based cleaners because they may damage the safety sign material.

Hazard Classification

Decals on this machine use symbols, color coding, and signal words to identify the following:



Safety alert symbol—used to alert you to potential personal injury hazards. Obey all safety messages that follow this symbol to avoid possible injury or death.

▲ DANGER

Indicates a hazardous situation which, if not avoided, will result in death or serious injury.

▲ WARNING

Indicates a hazardous situation which, if not avoided, could result in death or serious injury.

▲ CAUTION

Indicates a hazardous situation which, if not avoided, could result in minor or moderate injury.









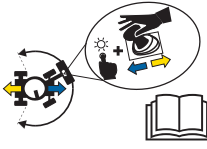

NOTICE

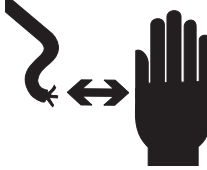
Indicates a property damage message.

Symbol and Hazard Pictorials Definitions

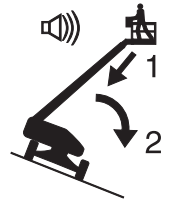
				
Fire hazard	Explosion hazard	Explosion hazard	Do not use ether or other high energy starting aids on machines equipped with glow plugs.	No smoking. No flame. Stop engine.
				
Fire extinguisher	No smoking	Explosion hazard	Electrocution hazard	Maintain required clearance
				
Tip-over hazard	Tip-over hazard	Tip-over hazard	Tip-over hazard	Tire specifications
				
Wheel load	Wind speed	Maximum capacity	Manual force	Weight of welder reduces capacity
				
Tie-down point	Lifting point	Platform tie-down instructions	Lifting & tie down instructions	Lanyard anchorage points

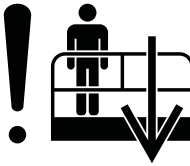
Symbol and Hazard Pictorials Definitions

 <p>Corrosive acid.</p>	 <p>Color coded direction arrows</p>	 <p>Runaway hazard</p>	 <p>Collision hazard</p>	 <p>Overhead obstruction</p>
 <p>Electrocution hazard</p>	 <p>Avoid contact</p>	 <p>Disconnect battery</p>	 <p>Voltage rating for power to platform</p>	 <p>Pressure rating for air line to platform</p>
 <p>Crush hazard</p>	 <p>Support the platform or boom during maintenance</p>	 <p>Read the service manual</p>	 <p>Explosion hazard</p>	 <p>Relieve all pressure</p>
<p>Recovery procedure if tilt alarm sounds while elevated.</p> <div style="display: flex; justify-content: space-around;"> <div data-bbox="235 1241 402 1440">  <p>Platform downhill: Retract boom. Lower boom.</p> </div> <div data-bbox="462 1241 634 1440">  <p>Platform uphill: Lower boom. Retract boom.</p> </div> </div>		 <p>Read the operator's manual</p>	 <p>Emergency lowering</p>	 <p>Access by trained and authorized personnel only</p>
 <p>Replace tracks with same tracks.</p>	 <p>Tracks load</p>			

General Safety

* These decals are model, option or configuration specific.

Pictures in this manual may show a boom with tires and wheels instead of tracks. All safety information and operating instructions still apply to the S-60 TRAX and the S-65 TRAX, even if the picture does not show the tracks.

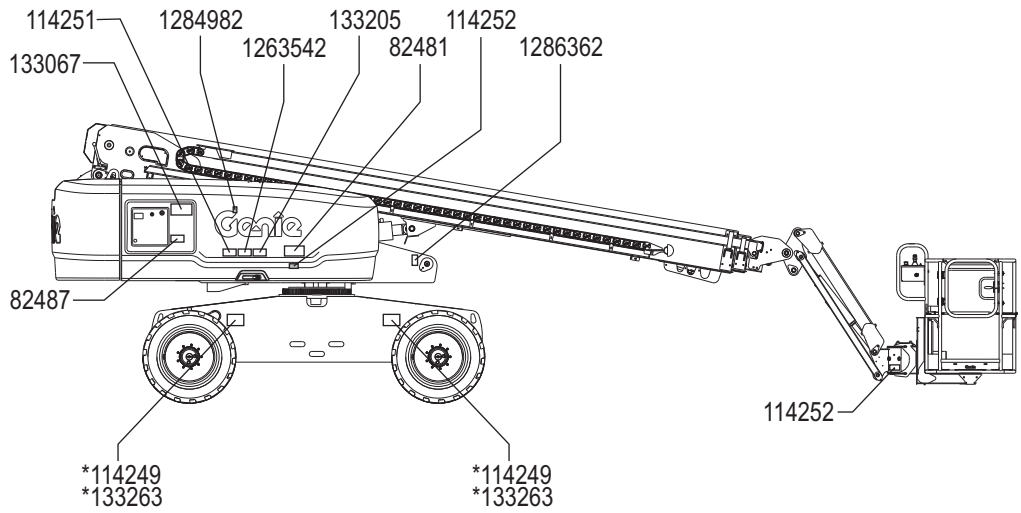
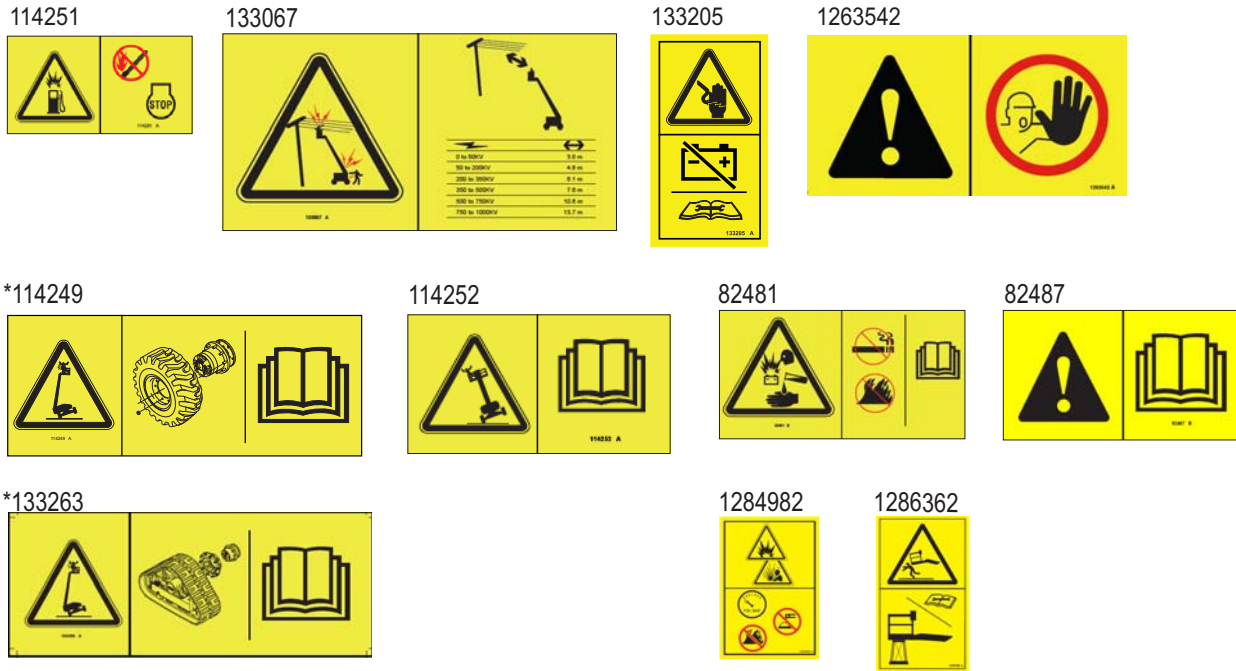

General Safety

* These decals are model, option or configuration specific.

Pictures in this manual may show a boom with tires and wheels instead of tracks. All safety information and operating instructions still apply to the S-60 TRAX and the S-65 TRAX, even if the picture does not show the tracks.

219958



*1284099



*82487



114473



*1284103 S-60 XC, S-60 TRAX



*1256425



*1284098 S-65 XC, S-65 TRAX



*1293617 S-60 HF



*1293616 S-65 HF



133067



219956



*1294340

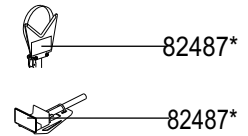
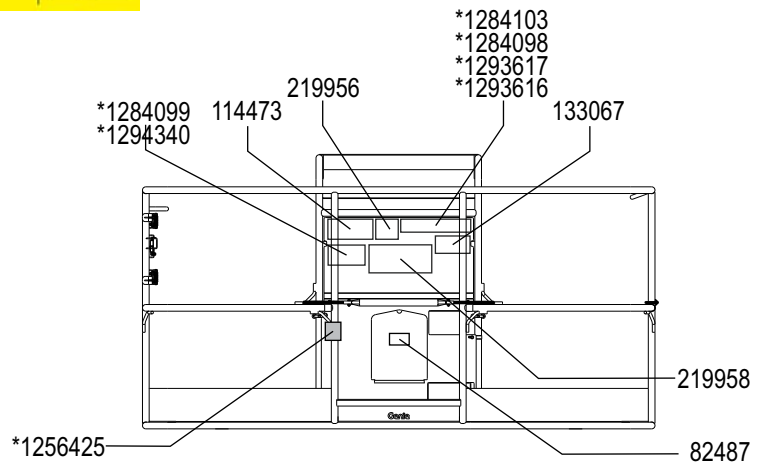

General Safety

* These decals are model, option or configuration specific.

Pictures in this manual may show a boom with tires and wheels instead of tracks. All safety information and operating instructions still apply to the S-60 TRAX and the S-65 TRAX, even if the picture does not show the tracks.

114251



133067



*1256425



1263542



*114249

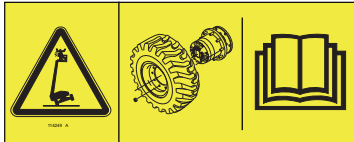

114252



1286362



*133263

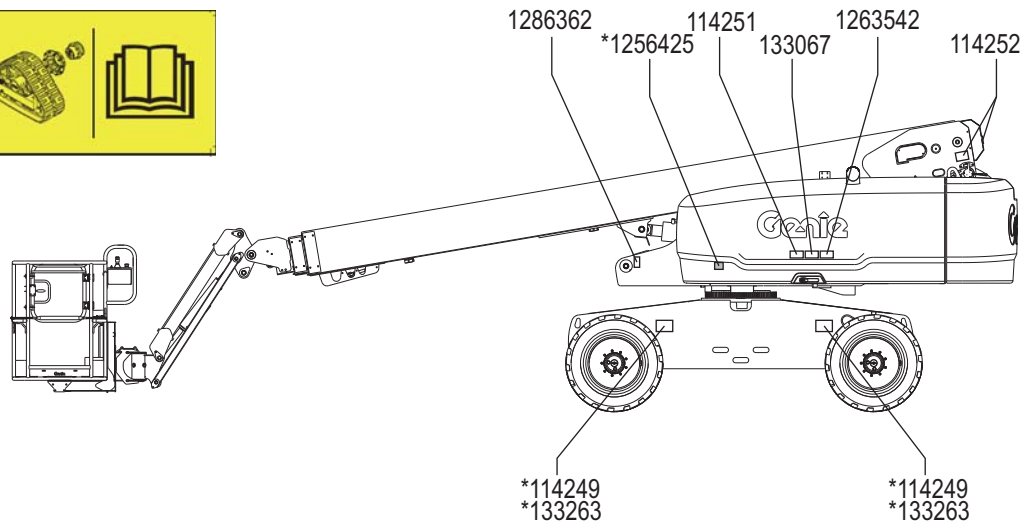

Personal Safety

Personal Fall Protection

Personal fall protection equipment (PFPE) is required when operating this machine.

Occupants must wear a safety belt or harness in accordance with governmental regulations. Attach the lanyard to the anchor provided in the platform.

Operators must comply with employer, job site and governmental rules regarding the use of personal protective equipment.

All PFPE must comply with applicable governmental regulations, and must be inspected and used in accordance with the PFPE manufacturer's instructions.

Work Area Safety

Pictures in this manual may show a boom with tires and wheels instead of tracks. All safety information and operating instructions still apply to the S-60 TRAX and the S-65 TRAX, even if the picture does not show the tracks.

⚠ Electrocuting Hazards

This machine is not electrically insulated and will not provide protection from contact with or proximity to electrical current.



Obey all local and governmental regulations regarding required clearance from electrical power lines. At a minimum, the required clearance contained in the chart below must be followed.

Line Voltage	Required Clearance
0 to 50KV	3.05 m
50 to 200KV	4.60 m
200 to 350KV	6.10 m
350 to 500KV	7.62 m
500 to 750KV	10.67 m
750 to 1000KV	13.72 m

Allow for platform movement, electrical line sway or sag, and beware of strong or gusty winds.

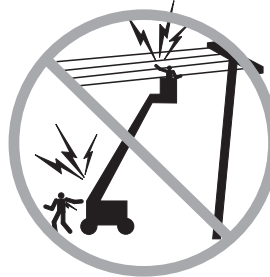

Keep away from the machine if it contacts energized power lines. Personnel on the ground or in the platform must not touch or operate the machine until energized power lines are shut off.

Do not operate the machine during lightning or storms.

Do not use the machine as a ground for welding.

⚠ Tip-over Hazards

Occupants, equipment and materials shall not exceed the maximum platform capacity for the restricted or unrestricted range of motion.

S-60 XC, S-65 XC, S-60 TRAX and S-65 TRAX	
Maximum platform capacity	300 kg
Unrestricted range of motion	
S-60 HF and S-65 HF	
Maximum platform capacity	272 kg
Unrestricted range of motion	
Maximum occupants	2
S-60 XC, S-65 XC, S-60 HF, S-65 HF, S-60 TRAX and S-65 TRAX	
Maximum platform capacity	454 kg
Restricted range of motion	
Maximum occupants	3

Work Area Safety

S-60 XC, S-65 XC, S-60 TRAX, S-65 TRAX: If the platform load is greater than 300 kg, do not move the platform into the unrestricted range of motion zone.

S-60 HF, S-65 HF: If the platform load is greater than 272 kg, do not move the platform into the unrestricted range of motion zone.

Do not exceed the maximum platform capacity.

S-60 XC, S-65 XC, S-60 TRAX, S-65 TRAX: Do not attach a platform rated at 300 kg (unrestricted range of motion) or 454 kg (restricted range of motion) to machines with any other rated load. See the serial label for the maximum rated load.

S-60 HF, S-65 HF: Do not attach a platform rated at 272 kg (unrestricted range of motion) or 454 kg (restricted range of motion) to machines with any other rated load. See the serial label for the maximum rated load.

The weight of options and accessories such as pipe cradles and welders will reduce the rated platform capacity, and must be subtracted from the platform capacity. See the decals with the options and accessories.

If using accessories, read, understand and obey the decals, instructions and manuals with the accessory.



Do not raise or extend the boom unless the machine is on a firm, level surface.



Do not depend on the tilt alarm as a level indicator. The tilt alarm sounds in the platform only when the machine is on a severe slope.

If the tilt alarm sounds while the boom is lowered: Do not extend, rotate or raise the boom above horizontal. Move the machine to a firm, level surface before raising the platform.

Work Area Safety

If the tilt alarm sounds when the platform is raised, use extreme caution. The machine not level indicator light will come on and the drive function in one or both directions will not operate. Identify the condition of the boom on the slope as shown below. Follow the steps to lower the boom before moving to a firm, level surface. Do not rotate the boom while lowering.

The recovery mode should be used only by trained and authorized personnel.

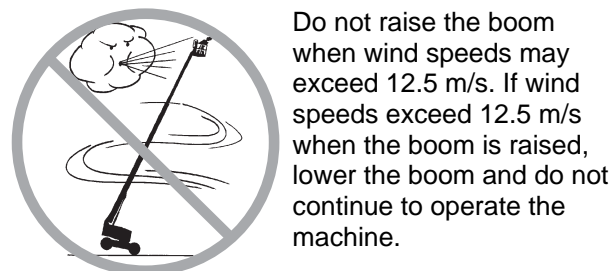
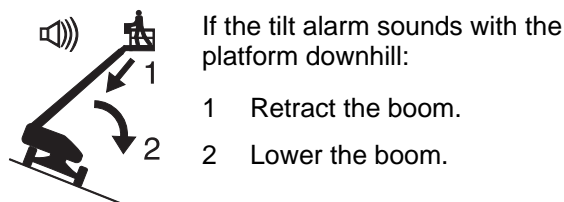
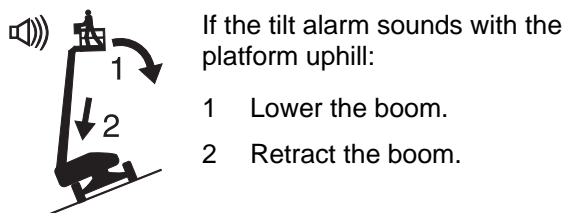

Do not operate the machine in strong or gusty winds. Do not increase the surface area of the platform or the load. Increasing the area exposed to the wind will decrease machine stability.



Use extreme care and slow speeds while driving the machine in the stowed position across uneven terrain, debris, unstable or slippery surfaces and near holes and drop-offs.

Do not drive the machine on or near uneven terrain, unstable surfaces or other hazardous conditions with the boom raised or extended.

Do not use the machine as a crane.

Do not push the machine or other objects with the boom.

Do not contact adjacent structures with the boom.

Do not tie the boom or platform to adjacent structures.

Do not place loads outside the platform perimeter.

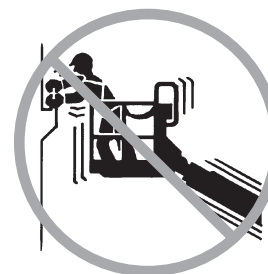

Do not push off or pull toward any object outside of the platform.

Maximum allowable manual force – 400 N

Work Area Safety

Do not alter or disable machine components that in any way affect safety and stability.

Do not replace items critical to machine stability with items of different weight or specification.

S-60 XC and S-65 XC: Do not replace factory-installed tires with tires of different specification or ply rating. Do not use air-filled tires. These machines are equipped with foam-filled tires. Wheel weight is critical to stability.

S-60 TRAX and S-65 TRAX: Do not replace tracks with tires. Track weight is critical to stability. Do not replace factory-installed tracks with tracks of different specification.

Do not allow any object to come near moving parts. The object could be thrown out of the Trax undercarriage.

Do not use the platform controls to free a platform that is caught, snagged, or otherwise prevented from normal motion by an adjacent structure. All personnel must be removed from the platform before attempting to free the platform using the ground controls.

Do not alter or modify a mobile elevating work platform without prior written permission from the manufacturer. Mounting attachments for holding tools or other materials onto the platform, toeboards, or guard rail system can increase the weight in the platform and the surface area of the platform or the load.



Do not place or attach fixed or overhanging loads to any part of this machine.



Do not place ladders or scaffolds in the platform or against any part of this machine.

Do not transport tools and materials unless they are evenly distributed and can be safely handled by person(s) in the platform.

Do not use the machine on a moving or mobile surface or vehicle.

Be sure the tires are in good condition and the lug nuts tightened.

Be sure all track lug nuts are properly tightened.

Work Area Safety

▲ Operation on Slopes Hazards

Do not drive the machine on a slope that exceeds the maximum uphill, downhill or side slope rating of the machine. Slope rating applies only to machines in the stowed position.

Maximum slope rating, stowed position, 4WD	
S-60 XC, S-65 XC, S-60 TRAX, S-65 TRAX	
Platform downhill	45% (24°)
Platform uphill	30% (17°)
Side slope	25% (14°)
Maximum slope rating, stowed position, 4WD	
S-60 HF, S-65 HF	
Platform downhill	40% (22°)
Platform uphill	40% (22°)
Side slope	25% (14°)

Note: Slope rating is subject to ground conditions with one person in the platform and adequate traction. Additional platform weight may reduce slope rating. See Driving on a Slope in the Operating Instructions section.

▲ Fall Hazards

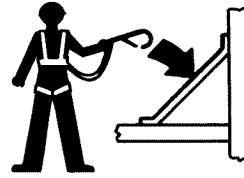

Occupants must wear a safety belt or harness in accordance with governmental regulations. Attach the lanyard to the anchor provided in the platform.



Do not sit, stand, or climb on the platform guard rails. Maintain a firm footing on the platform floor at all times.



Do not climb down from the platform when raised.

Keep the platform floor clear of debris.

Lower the platform entry mid-rail or close the entry gate before operating.

Do not enter or exit the platform unless the machine is in the stowed position and the platform is at ground level.

Hazards related with the specific product application of exiting at height have been considered in the design of the machine, for further information contact Genie (see section Contacting the Manufacturer).

Work Area Safety

▲ Collision Hazards

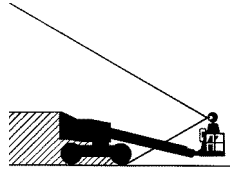

Be aware of limited sight distance and blind spots when driving or operating.

Be aware of the boom position and tailswing when rotating the turntable.



Check the work area for overhead obstructions or other possible hazards.



Be aware of crushing hazards when grasping the platform guard rail.

Operators must comply with employer, job site, and governmental rules regarding use of personal protective equipment.

Observe and use the color-coded direction arrows on the platform controls and drive chassis for drive and steer functions.



Do not lower the boom unless the area below is clear of personnel and obstructions.



Limit travel speed according to the condition of the ground surface, congestion, slope, location of personnel, and any other factors which may cause collision.

Do not operate a boom in the path of any crane unless the controls of the crane have been locked out and/or precautions have been taken to prevent any potential collision.

No stunt driving or horseplay while operating a machine.

Work Area Safety

▲ Bodily Injury Hazard

Always operate the machine in a well-ventilated area to avoid carbon monoxide poisoning.

Do not operate the machine with a hydraulic oil or air leak. An air leak or hydraulic leak can penetrate and/or burn skin.

Improper contact with components under any cover will cause serious injury. Only trained maintenance personnel should access compartments. Access by the operator is only advised when performing a pre-operation inspection. All compartments must remain closed and secured during operation.

▲ Explosion and Fire Hazards

Do not start the engine if you smell or detect liquid petroleum gas (LPG), gasoline, diesel fuel or other explosive substances.

Do not refuel the machine with the engine running.

Refuel the machine and charge the battery only in an open, well-ventilated area away from sparks, flames and lighted tobacco.

Do not operate the machine or charge the battery in hazardous locations or locations where potentially flammable or explosive gases or particles may be present.

Do not spray ether into engines equipped with glow plugs.

▲ Damaged Machine Hazards

Do not use a damaged or malfunctioning machine.

Conduct a thorough pre-operation inspection of the machine and test all functions before each work shift. Immediately tag and remove from service a damaged or malfunctioning machine.

Be sure all maintenance has been performed as specified in this manual and the appropriate Genie service manual.

Be sure all decals are in place and legible.

Be sure the operator's, safety, and responsibilities manuals are complete, legible, and in the storage container located on the machine.

▲ Component Damage Hazards

Do not use any battery or charger greater than 12V to jump-start the engine.

Do not use the machine as a ground for welding.

Do not operate the machine in locations where extremely high magnetic fields may be present.

Work Area Safety

▲ Battery Safety

Burn Hazards



Batteries contain acid. Always wear protective clothing and eye wear when working with batteries.

Avoid spilling or contacting battery acid. Neutralize battery acid spills with baking soda and water.

Explosion Hazards



Keep sparks, flames, and lighted tobacco away from batteries. Batteries emit explosive gas.

▲ Contact Alarm Safety

Read, understand and obey all warnings and instructions provided with the contact alarm.

Do not exceed the rated platform capacity. The weight of the contact alarm assembly will reduce the rated platform capacity and must be subtracted from the total platform load.

The contact alarm assembly weighs 4.5 kg.

Be sure the contact alarm is securely installed.

▲ Electrocution Hazard

Avoid contact with electrical terminals.

Work Area Safety

▲ Pipe Cradle Safety

Read, understand, and obey all warnings and instructions provided with the pipe cradles.

Do not exceed the rated platform capacity. The pipe cradle assembly and the weight in the pipe cradles will reduce rated platform capacity and must be factored into total platform load.

The pipe cradle assembly weighs 9.5 kg.

The maximum capacity of the pipe cradle assembly is 91 kg.

The weight of the pipe cradle assembly and the load in the pipe cradles may limit the maximum number of occupants in platform.

Center the load within the perimeter of the platform.

Secure the load to the platform.

Do not obstruct the entrance or the exit of the platform.

Do not obstruct the ability to operate the platform controls or the red Emergency Stop button.

Do not operate unless you are adequately instructed and are aware of all of the hazards associated with movement of the platform with an overhanging load.

Do not cause a horizontal force or side load to machine by raising or lowering a fixed or overhanging load.

Electrocution Hazard: Keep pipes away from all energized electrical conductors.

▲ Panel Cradle Safety

Read, understand and obey all warnings and instructions provided with the panel cradles.

Do not exceed the rated platform capacity. The combined weight of the cradles, panels, occupants, tools and any other equipment must not exceed rated capacity.

The panel cradle assembly weighs 13.6 kg.

The maximum capacity of the panel cradles is 113 kg.

The weight of the panel cradles and the load in the panel cradles may limit the maximum number of occupants in platform to one person.

Secure the cradles to the platform. Secure the panel(s) to the platform railing using the straps provided.

Do not operate unless you are adequately instructed and are aware of all hazards associated with lifting panels.

Do not cause a horizontal force or side load to machine by raising or lowering a fixed or overhanging load.

Maximum vertical height of panels: 1.2 m.

Maximum wind speed: 6.7 m/sec.

Maximum panel area: 3 m².

Work Area Safety

▲ Welder Safety

Read, understand and obey all warnings and instructions provided with the welding power unit.

Do not connect weld leads or cables unless the welding power unit is turned off at the platform controls.

Do not operate unless the weld cables are properly connected and the welder is properly grounded.

The weight of the welder will reduce the rated platform capacity and must be factored into the total platform load. The welder power supply weighs 34 kg.

Do not operate the welder unless a fire extinguisher is immediately available for instant use, per OSHA regulation 1926.352(d).

Lockout After Each Use

- 1 Select a safe parking location—firm level surface, clear of obstruction and traffic.
- 2 Retract and lower the boom to the stowed position.
- 3 Rotate the turntable so that the boom is between the non-steer wheels, or non-steer tracks.
- 4 Turn the key switch to the off position and remove the key to secure from unauthorized use.

Legend

Pictures in this manual may show a boom with tires and wheels instead of tracks. All safety information and operating instructions still apply to the S-60 TRAX and the S-65 TRAX, even if the picture does not show the tracks.

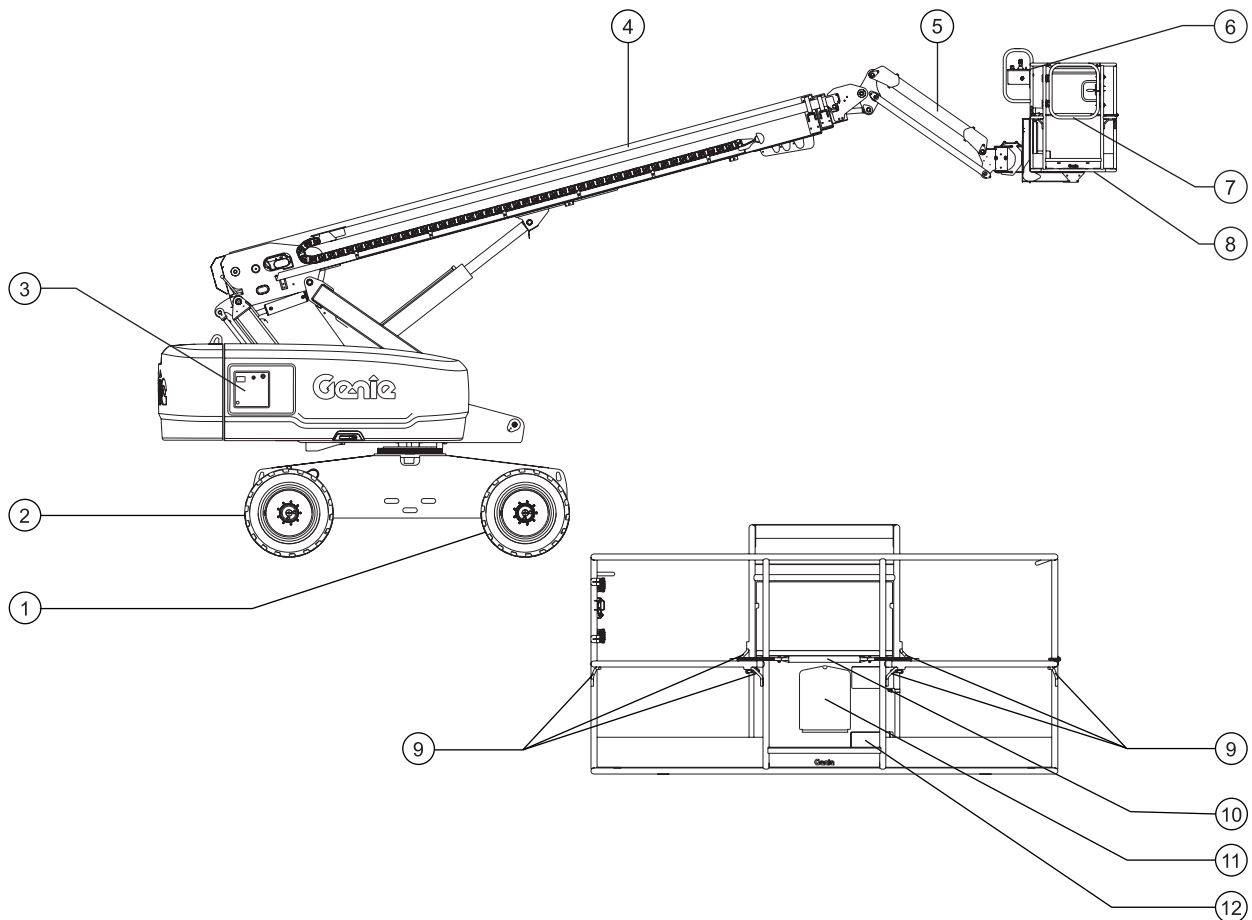

- 1 Non-steer tire or non-steer track
- 2 Steer tire or steer track
- 3 Ground controls
- 4 Boom
- 5 Jib boom (if equipped)
- 6 Platform controls

- 7 Swing gate
- 8 Platform
- 9 Lanyard anchorage points
- 10 Sliding mid-rail
- 11 Manual storage container
- 12 Foot switch



Controls

Pictures in this manual may show a boom with tires and wheels instead of tracks. All safety information and operating instructions still apply to the S-60 TRAX and the S-65 TRAX, even if the picture does not show the tracks.

The ground control station is to be used as a means to raise the platform for storage purposes and for function tests. The ground control station can be used in the event of an emergency to rescue and incapacitated person in the platform. When the ground control station is selected, the platform controls are inoperable, including the E-stop switch.

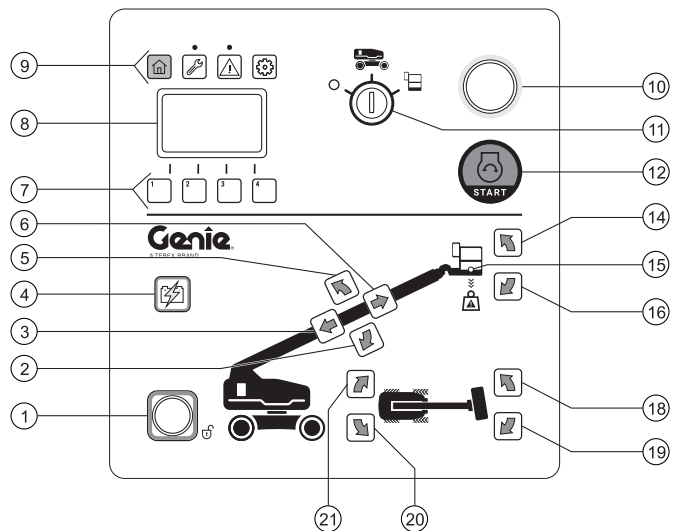
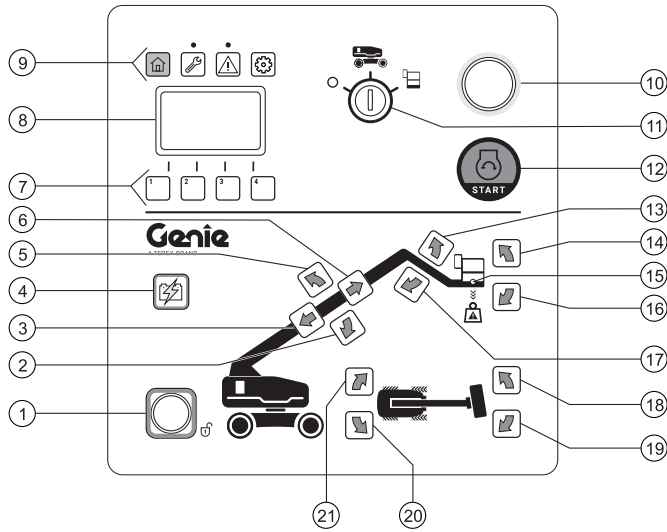

Controls

Ground Control Panel

1 Function enable button

Press and hold the function enable button to enable the functions on the ground control panel to operate.

2 Boom down button

Press the boom down button and the boom will lower.

3 Boom retract button

Press the boom retract button and the boom will retract.

4 Emergency power button

Use emergency power if the primary power source (engine) fails. Simultaneously hold the emergency power button and activate the desired function.

5 Boom up button

Press the boom up button and the boom will raise.

6 Boom extend button

Press the boom extend button and the boom will extend.

7 LCD readout screen navigation buttons

8 LCD readout screen

Screen displays hour meter, voltage, oil pressure and coolant temperature. Screen also displays fault codes and other service information.

9 LCD screen menu buttons

Use the LCD screen menu buttons to access different menus.



The Home button will show the model, hour meter and access to engine gauges.



The Maintenance button will show the maintenance interval screen. Light on indicates a service interval has lapsed.



The Fault button will show current faults and allow access to fault logs. Light on indicates an active fault condition.



The Setup button allows service personnel to access configuration screens.

10 Red Emergency Stop button

Push in the red Emergency Stop button to the off position to stop all functions and turn the engine off. Pull out the red Emergency Stop button to the on position to operate the machine.

Controls

11 Key switch for off/ground/platform selection

Turn the key switch to the off position and the machine will be off. Turn the key switch to the ground position and the ground controls will operate. Turn the key switch to the platform position and the platform controls will operate.

12 Engine start button

Press the engine start button to start the engine.

13 Jib boom up button

Press the jib boom up button and the jib boom will raise.

14 Platform level up button

Press the platform level up button and the level of the platform will raise.

15 Platform overload indicator light

Light flashing indicates the platform is overloaded. The engine will stop and no functions will operate.

Note: An alarm will sound at the platform when an overload condition occurs and will stop sounding when weight is removed from the platform.

16 Platform level down button

Press the platform level down button and the level of the platform will lower.

17 Jib boom down button

Press the jib boom down button and the jib boom will lower.

18 Platform rotate right button

Press the platform rotate right button and the platform will rotate to the right.

19 Platform rotate left button

Press the platform rotate left button and the platform will rotate to the left.

20 Turntable rotate right button

Press the turntable rotate right button and the turntable will rotate to the right.

21 Turntable rotate left button

Press the turntable rotate left button and the turntable will rotate to the left.

Controls

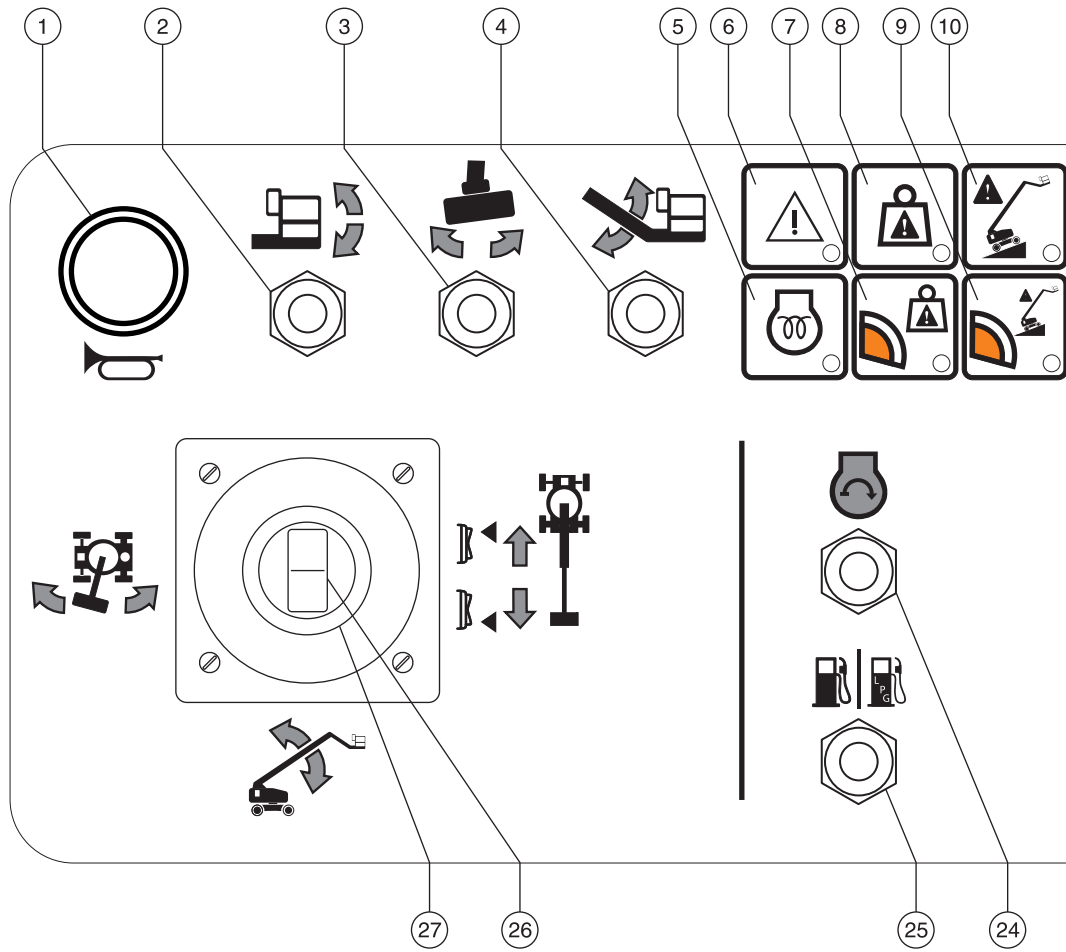

Platform Control Panel

Controls

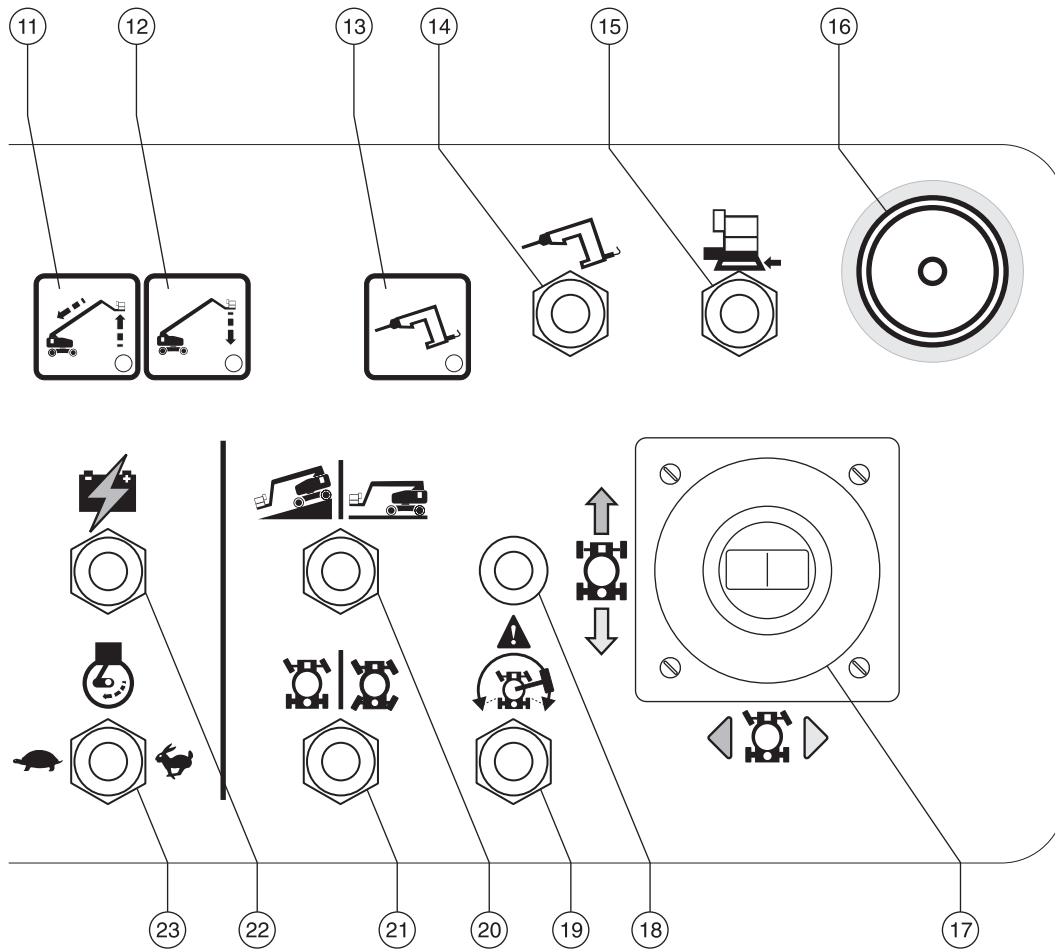

Controls

Platform Control Panel

1 Horn button

Press this button and the horn will sound. Release the button and the horn will stop.

2 Platform level switch

Move the platform level switch up and the level of the platform will raise. Move the platform level switch down and the level of the platform will lower.



3 Platform rotate switch

Move the platform rotate switch to the left and the platform will rotate left. Move the platform rotate switch to the right and the platform will rotate right.



4 Jib boom up/down switch

Move the jib boom switch up and the jib boom will raise. Move the jib boom switch down and the jib boom will lower.

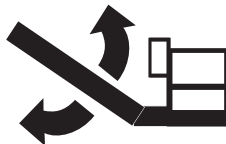

5 Glow plug indicator light

Light on indicates the glow plugs are on.

6 Fault indicator light

Light on indicates a system fault.

7 Restricted range of motion indicator light, weight.

Light on indicates restricted range of motion due to platform weight.



8 Platform overload indicator light

Light flashing indicates the platform is overloaded. The engine will stop and no functions will operate. Remove weight until the light goes off and then restart the engine.

9 Restricted range of motion indicator light, slope.

Light on indicates restricted range of motion due to slope angle.



10 Machine on incline indicator light

Light on indicates the tilt sensor activation settings have been exceeded. See the instructions in the Operating Instructions section.

Controls

- 11 Raise/retract boom indicator light
Raise/retract the boom until the light is off.
- 12 Lower boom indicator light
Lower the boom until the light is off.
- 13 Generator indicator light
Light on indicates the generator is in use.
- 14 Generator switch (if equipped)
Move the generator switch up to activate the generator. Move the switch down to turn off the generator.
- 15 Aircraft protection override switch (if equipped)
Move and hold the aircraft protection override switch to operate the machine when the platform bumper is against an object.
- 16 Red Emergency Stop button
Push in the red Emergency Stop button to the off position to stop all functions and turn the engine off. Pull out the red Emergency Stop button to the on position to operate the machine.
- 17 Dual axis proportional control handle for drive and steer functions
OR Proportional control handle for drive function and thumb rocker for steer function.
Move the control handle in the direction indicated by the blue arrow on the control panel and the machine will drive forward. Move the control handle in the direction indicated by the yellow arrow and the machine will drive backwards. Move the control handle in the direction indicated by the blue triangle and the machine will steer to the left. Move the control handle in the direction indicated by the yellow triangle and the machine will steer to the right.
OR
Move the control handle in the direction indicated by the blue arrow on the control panel and the machine will drive forward. Move the control handle in the direction indicated by the yellow arrow and the machine will drive backwards. Press the left side of the thumb rocker and the machine will steer to the left. Press the right side of the thumb rocker and the machine will steer to the right.
- 18 Drive enable indicator light
Light flashing indicates that the boom has moved just past either non-steer wheel or non-steer track and drive function has been interrupted.

Controls

19 Drive enable switch

To drive when the drive enable light is flashing, hold the drive enable switch to either side and slowly move the drive control handle off center. Be aware that the machine may move in the opposite direction that the drive and steer controls are moved.

20 Drive speed select switch

Machine on incline symbol: Low range operation for inclines.

Machine on level surface symbol: High range operation for maximum drive speed.

21 Steer mode select switch (if equipped)

Move the steer mode select switch to the left to select square-end steer. Move the steer mode select switch to the right to select coordinated steer.

22 Emergency power switch

Use emergency power if the primary power source fails.

Simultaneously hold the emergency power switch up or down and activate the desired function.

23 Engine RPM select switch

Move the engine RPM select switch to the turtle position to activate low idle. Move the engine RPM speed select switch to the rabbit position to activate high idle.

24 Engine start switch

Move the engine start switch to either side to start the engine.

25 Gasoline/LPG models: Fuel select switch

Move the fuel select switch to the gasoline position to select gasoline. Move the fuel select switch to the LPG position to select LPG.

26 Thumb rocker switch for boom extend/retract function

Push the top of the rocker switch and boom will retract. Push the bottom of the rocker switch and the boom will extend.

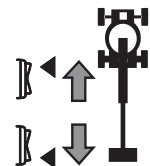

27 Dual axis proportional control handle for boom up/down and turntable rotate left/right functions

Move the control handle up and the boom will raise. Move the control handle down and the boom will lower.



Move the control handle to the right and the turntable will rotate to the right. Move the control handle to the left and the turntable will rotate to the left.



Inspections

Pictures in this manual may show a boom with tires and wheels instead of tracks. All safety information and operating instructions still apply to the S-60 TRAX and the S-65 TRAX, even if the picture does not show the tracks.



Do Not Operate Unless:

- You learn and practice the principles of safe machine operation contained in this operator's manual.

- 1 Avoid hazardous situations.
- 2 Always perform a pre-operation inspection.**

Know and understand the pre-operation inspection before going on to the next section.

- 3 Always perform function tests prior to use.
- 4 Inspect the workplace.
- 5 Only use the machine as it was intended.

Pre-operation Inspection Fundamentals

It is the responsibility of the operator to perform a pre-operation inspection and routine maintenance.

The pre-operation inspection is a visual inspection performed by the operator prior to each work shift. The inspection is designed to discover if anything is apparently wrong with a machine before the operator performs the function tests.

The pre-operation inspection also serves to determine if routine maintenance procedures are required. Only routine maintenance items specified in this manual may be performed by the operator.

Refer to the list on the next page and check each of the items.

If damage or any unauthorized variation from factory delivered condition is discovered, the machine must be tagged and removed from service.

Repairs to the machine may only be made by a qualified service technician, according to the manufacturer's specifications. After repairs are completed, the operator must perform a pre-operation inspection again before going on to the function tests.

Scheduled maintenance inspections shall be performed by qualified service technicians, according to the manufacturer's specifications and the requirements listed in the responsibilities manual.

Inspections

Pre-operation Inspection

- Be sure that the operator's, safety, and responsibilities manuals are complete, legible and in the storage container located in the platform.
- Be sure that all decals are legible and in place. See Inspections section.
- Check for hydraulic oil leaks and proper oil level. Add oil if needed. See Maintenance section.
- Check for battery fluid leaks and proper fluid level. Add distilled water if needed. See Maintenance section.
- Check for engine oil leaks and proper oil level. Add oil if needed. See Maintenance section.
- Check for engine coolant leaks and proper level of coolant. Add coolant if needed. See Maintenance section.
- Check rubber tracks for signs of wear, cracks and cuts.

Check the following components or areas for damage, improperly installed, or missing parts and unauthorized modifications:

- Electrical components, wiring, and electrical cables
- Hydraulic hoses, fittings, cylinders, and manifolds
- Fuel and hydraulic tanks
- Drive and turntable motors and drive hubs
- Wear pads
- Tires and wheels
- Tracks, sprocket, idler, bogey, undercarriage/frame, tensioner
- Engine and related components
- Limit switches and horn
- Contact alarm

- Primary boom angle sensor
- Turntable level sensor
- String pot length sensor
- Alarms and beacons (if equipped)
- Nuts, bolts and other fasteners
- Platform entry mid-rail and gate
- Platform load cell
- Lanyard anchorage points

Check entire machine for:

- Cracks in welds or structural components
- Dents or damage to machine
- Excessive rust, corrosion or oxidation
- Be sure that all structural and other critical components are present and all associated fasteners and pins are in place and properly tightened.
- After you complete your inspection, be sure that all compartment covers are in place and latched.

Pictures in this manual may show a boom with tires and wheels instead of tracks. All safety information and operating instructions still apply to the S-60 TRAX and the S-65 TRAX, even if the picture does not show the tracks.

Inspections



Do Not Operate Unless:

- You learn and practice the principles of safe machine operation contained in this operator's manual.
 - 1 Avoid hazardous situations.
 - 2 Always perform a pre-operation inspection.
 - 3 Always perform function tests prior to use.**

Know and understand the function tests before going on to the next section.

- 4 Inspect the workplace.
- 5 Only use the machine as it was intended.

Function Test Fundamentals

The function tests are designed to discover any malfunctions before the machine is put into service. The operator must follow the step-by-step instructions to test all machine functions.

A malfunctioning machine must never be used. If malfunctions are discovered, the machine must be tagged and removed from service. Repairs to the machine may only be made by a qualified service technician, according to the manufacturer's specifications.

After repairs are completed, the operator must perform a pre-operation inspection and function tests again before putting the machine into service.

Inspections

At the Ground Controls

- 1 Select a test area that is firm, level and free of obstruction.
- 2 Turn the key switch to ground control.
- 3 Pull out the red Emergency Stop button to the on position.
- ⊙ Result: The alarm should sound at the ground controls.
- 4 Start the engine. See Operating Instructions section.
- ⊙ Result: The beacons (if equipped) should flash.

Test Emergency Stop

- 5 Push in the red Emergency Stop button to the off position.
- ⊙ Result: The engine should shut off and no functions should operate.
- 6 Pull out the red Emergency Stop button to the on position and restart the engine.

Test Machine Functions

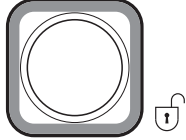
- 7 Do not push the function enable button. Attempt to activate each boom and platform function button.
 
- ⊙ Result: No boom and platform functions should operate.
- 8 Press and hold the function enable button and activate each boom and platform function button.
- ⊙ Result: All boom and platform functions should operate through a full cycle. The descent alarm should sound while the boom is lowering.

Test the Tilt Sensor

- 9 Press the Maintenance button above the LCD screen. Navigate to the Real-time Data screen.
 
- ⊙ Result: The LCD screen should display the chassis angle and boom angle in degrees.

Inspections

Test Emergency Power

- 10 Turn the key switch to ground control and shut the engine off.
- 11 Pull out the red Emergency Stop button to the on position.
- 12 Simultaneously push the emergency power button and activate each boom function button.

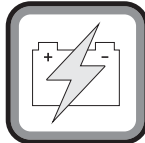

Note: To conserve battery power, test each function through a partial cycle.

- ⊙ Result: All boom functions should operate.
- 13 Turn the key switch to platform control.

At the Platform Controls

Test the Tilt Sensor Alarm

- 14 Enter the platform and pull out the red Emergency Stop button.
- ⊙ Result: The alarm should sound at the platform controls.

Test Emergency Stop

- 15 Start the engine.
 - 16 Push in the platform red Emergency Stop button to the off position.
- ⊙ Result: The engine should shut off and no functions should operate.
- 17 Pull out the red Emergency Stop button and restart the engine.

Test the Horn

- 18 Press the horn button.
- ⊙ Result: The horn should sound.

Test the Foot Switch

- 19 Push in the platform red Emergency Stop button to the off position.
 - 20 Pull out the red Emergency Stop button to the on position and do not start the engine.
 - 21 Press down the foot switch and attempt to start the engine by moving the start toggle switch to either side.
- ⊙ Result: The engine should not start.
- 22 Do not press down the foot switch and restart the engine.
- ⊙ Result: The engine should start.
- 23 Do not press down the foot switch and test each machine function.
- ⊙ Result: No functions should operate.

Inspections

Test Machine Functions

- 24 Press down the foot switch.
 - 25 Activate each machine function control handle or toggle switch.
- ⊙ Result: All boom and platform functions should operate through a full cycle.

Test the Steering

- 26 Press down the foot switch.
 - 27 Press the thumb rocker switch on top of the drive control handle in the direction indicated by the blue triangle on the control panel OR slowly move the control handle in the direction indicated by the blue triangle.
- ⊙ Result: The steer wheels, or steer tracks should turn in the direction that the blue triangles point on the drive chassis.
- 28 Press the thumb rocker switch in the direction indicated by the yellow triangle on the control panel OR slowly move the control handle in the direction indicated by the yellow triangle.
- ⊙ Result: The steer wheels, or steer tracks should turn in the direction that the yellow triangles point on the drive chassis.

Test Drive and Braking

- 29 Press down the foot switch.
 - 30 Slowly move the drive control handle in the direction indicated by the blue arrow on the control panel until the machine begins to move, then return the handle to the center position.
- ⊙ Result: The machine should move in the direction that the blue arrow points on the drive chassis, then come to an abrupt stop.
- 31 Slowly move the control handle in the direction indicated by the yellow arrow on the control panel until the machine begins to move, then return the handle to the center position.
- ⊙ Result: The machine should move in the direction that the yellow arrow points on the drive chassis, then come to an abrupt stop.

Note: The brakes must be able to hold the machine on any slope it is able to climb.

Inspections

Test the Oscillating Axle

- 32 Drive the right steer tire, or track up onto a 15 cm block or curb.
 - ⊙ Result: The three remaining tires should stay in firm contact with the ground.
- 33 Drive the left steer tire, or track up onto a 15 cm block or curb.
 - ⊙ Result: The three remaining tires should stay in firm contact with the ground.
- 34 Drive both steer tires, or tracks up onto a 15 cm block or curb.
 - ⊙ Result: The non-steer tires should stay in firm contact with the ground.

Test the Drive Enable System

- 35 Press down the foot switch and lower the boom to the stowed position.
- 36 Rotate the turntable until the boom moves past one of the non-steer wheels, or non-steer tracks.
 - ⊙ Result: The drive enable indicator light should flash while the boom is anywhere in the range shown.
- 37 Move the drive control handle off center.
 - ⊙ Result: The drive function should not operate.
- 38 Move and hold the drive enable toggle switch to either side and slowly move the drive control handle off center.
 - ⊙ Result: The drive function should operate.

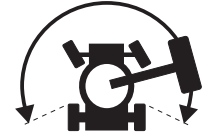

Note: When the drive enable system is in use, the machine may drive in the opposite direction that the drive and steer control handle is moved.

Use the color-coded direction arrows on the platform controls and the drive chassis to identify the direction of travel.

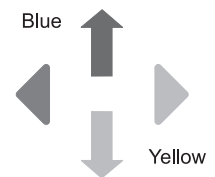

Inspections

Test Limited Drive Speed

- 39 Press down the foot switch.
- 40 Raise the boom approximately 10° above horizontal.

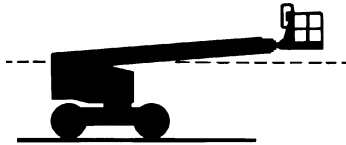

- 41 Slowly move the control handle to full drive position.
- ⊙ Result: The maximum achievable drive speed with the boom raised should not exceed 32 cm/s.
- 42 Lower the boom to the stowed position.
- 43 Extend the boom 17 cm.
- 44 Slowly move the control handle to full drive position.
- ⊙ Result: The maximum achievable drive speed with the boom raised should not exceed 32 cm/s.

If the drive speed with the boom raised or extended exceeds 32 cm/s, immediately tag and remove the machine from service.

Test Drive Tilt Cutout

- 45 Press down the foot switch.
- 46 With the boom fully stowed, drive the machine onto a slope where the machine pitch angle is greater than 7° (front to back).
- ⊙ Result: The machine should continue to drive.
- 47 Return the machine to level ground and extend the boom approximately 17 cm.
- 48 Drive the machine onto a slope where the pitch angle is greater than 7° (front to back).
- ⊙ Result: The machine should stop once the machine reaches 7° of chassis tilt and the alarm should sound at the platform controls.
- 49 Retract the boom to the stowed position.
- ⊙ Result: The machine should drive.
- 50 Return to level ground and raise the boom to approximately 10° above horizontal.
- 51 Drive the machine onto a slope where the pitch angle is greater than 7° (front to back).
- ⊙ Result: The machine should stop once the machine reaches 7° of chassis tilt and the alarm should sound at the platform controls.
- 52 While on the slope, attempt to raise and extend the boom.
- ⊙ Result: The boom raise and extend functions should not operate.
- 53 Lower the boom to the stowed position.
- ⊙ Result: The machine should drive.
- 54 Return to level ground and stow the boom.

Inspections

- 55 Press down the foot switch.
- 56 With the boom fully stowed, drive the machine onto a slope where the roll angle is greater than 5° (side to side).
- ⊙ Result: The machine should continue to drive.
- 57 Return the machine to level ground and extend the boom approximately 17 cm.
- 58 **S-60 XC, S-65 XC, S-60 TRAX and S-65 TRAX:** Drive the machine onto a slope where the roll angle is greater than 5° (side to side).
- S-60 HF and S-65 HF:** Drive the machine onto a slope where the roll angle is greater than 4° (side to side).
- ⊙ Result: **S-60 XC, S-65 XC, S-60 TRAX and S-65 TRAX:** The machine should stop once the machine reaches 5° of chassis tilt and the alarm should sound at the platform controls.
 - ⊙ Result: **S-60 HF and S-65 HF:** The machine should stop once the machine reaches 4° of chassis tilt and the alarm should sound at the platform controls.
- 59 Retract the boom to the stowed position.
- ⊙ Result: The machine should drive.
- 60 Return to level ground and raise the boom to approximately 10° above horizontal.
- 61 **S-60 XC, S-65 XC, S-60 TRAX and S-65 TRAX:** Drive the machine onto a slope where the roll angle is greater than 5° (side to side).
- S-60 HF and S-65 HF:** Drive the machine onto a slope where the roll angle is greater than 4° (side to side).
- ⊙ Result: **S-60 XC, S-65 XC, S-60 TRAX and S-65 TRAX:** The machine should stop once the machine reaches 5° of chassis tilt and the alarm should sound at the platform controls.
 - ⊙ Result: **S-60 HF and S-65 HF:** The machine should stop once the machine reaches 4° of chassis tilt and the alarm should sound at the platform controls.
- 62 While on the slope, attempt to raise and extend the boom.
- ⊙ Result: The boom raise and extend functions should not operate.
- 63 Lower the boom to the stowed position.
- ⊙ Result: The machine should drive.
- 64 Return to level ground and stow the boom.

Inspections

Test Emergency Power

- 65 Shut the engine off.
- 66 Pull out the red Emergency Stop button to the on position.
- 67 Press down the foot switch.
- 68 Simultaneously hold the emergency power switch on and activate each function control handle or toggle switch.

Note: To conserve battery power, test each function through a partial cycle.

- ⊙ Result: All boom and steer functions should operate. Drive functions should not operate with emergency power.

Test the Lift/Drive Select Function

- 69 Start the engine.
 - 70 Press down the foot switch.
 - 71 Move the drive control handle off center and activate a boom function control handle.
- ⊙ Result: No boom functions should operate. The machine will move in the direction indicated on the control panel.

Test the Contact Alarm (if equipped)

- 72 Do not activate the foot switch and press on the contact alarm cable to release the actuator from the switch socket.
 - ⊙ Result: The contact alarm lights will not flash and the machine horn will not sound.
- 73 Activate the foot switch by pressing the foot switch down.
 - ⊙ Result: The contact alarm lights will flash and the machine horn will sound.
- 74 Insert the actuator into the switch socket.
 - ⊙ Result: The lights and horn will turn off.
- 75 Activate the foot switch by pressing the foot switch down and press on the contact alarm cable to release the actuator from the switch socket.
 - ⊙ Result: The contact alarm lights will flash and the machine horn will sound.
- 76 Operate each machine function.
 - ⊙ Result: All machine functions should not operate.

Inspections

77 Insert the actuator into the switch socket.

☉ Result: The lights and horn will turn off.

78 Operate each machine function.

☉ Result: All machine functions should operate.

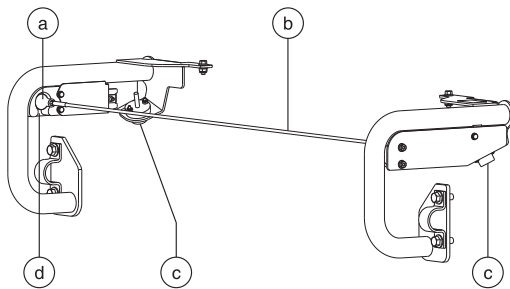

- a actuator
- b contact alarm cable
- c flashing alarm
- d switch socket

Test Aircraft Protection Package (if equipped)

Note: Two people may be required to perform this test.

79 Move the yellow bumper at the bottom of the platform 10 cm in any direction.

80 Activate each function control handle or toggle switch.

☉ Result: No boom and steer functions should operate.

81 Move and hold the function override switch.

82 Activate each function control handle or toggle switch.

☉ Result: All boom and steer functions should operate.

Inspections



Do Not Operate Unless:

- ☑ You learn and practice the principles of safe machine operation contained in this operator's manual.
 - 1 Avoid hazardous situations.
 - 2 Always perform a pre-operation inspection.
 - 3 Always perform function tests prior to use.
 - 4 Inspect the workplace.**

Know and understand the workplace inspection before going on to the next section.
 - 5 Only use the machine as it was intended.

Workplace Inspection Fundamentals

The workplace inspection helps the operator determine if the workplace is suitable for safe machine operation. It should be performed by the operator prior to moving the machine to the workplace.

It is the operator's responsibility to read and remember the workplace hazards, then watch for and avoid them while moving, setting up, and operating the machine.

Workplace Inspection Checklist

Be aware of and avoid the following hazardous situations:

- drop-offs or holes
- bumps, floor obstructions, or debris
- sloped surfaces
- unstable or slippery surfaces
- overhead obstructions and high voltage conductors
- hazardous locations
- inadequate surface support to withstand all load forces imposed by the machine
- wind and weather conditions
- the presence of unauthorized personnel
- other possible unsafe conditions

Inspections

Inspection for Decals with Symbols

Determine whether the decals on your machine have words or symbols. Use the appropriate inspection to verify that all decals are legible and in place.

Below is a numerical list with quantities and descriptions.

Part No.	Decal Description	Qty
27204	Arrow – Blue	1
27205	Arrow – Yellow	1
27206	Triangle – Blue	2
27207	Triangle – Yellow	2
28158	Label – Unleaded	1
28159	Label – Diesel	1
28160	Label – Liquid Petroleum Gas	1
28174	Label – Power to Platform, 230V	2
28235	Label – Power to Platform, 115V	2
44981	Label – Air Line to Platform (option)	2
52475	Label – Transport Tie Down	6
65278	Caution – No Step	2
72086	Label – Lifting Point	4
82240	Label – 105 dB	1
82481	Label – Battery/Charger Safety	1
82487	Label – Read the Manual	2
82487	Label – Read the Manual (one decal on each panel cradle)	2
82487	Label – Read the Manual (one decal on each pipe cradle)	2
97815	Label – Lower Mid-rail	1
114249	Label – Tip-over Hazard, Tires	4
114251	Label – Explosion Hazard	2
114252	Label – Tip-over Hazard, Limit Switches	4
114473	Label – Tilt Alarm	1
133067	Label – Electrocutation Hazard	3
133205	Label – Electrocutation/Burn Hazard	1
133263	Label – Tracks Specifications	4
215526	Label – Belt Routing (MSG-425)	1
219956	Label – Platform Overload	1
219958	Label – Tip-over, Crush Hazard	1

Part No.	Decal Description	Qty
1256425	Label – Danger, Electrocutation Hazard	3
1258949	Ground Control Panel, S-65 XC, S-65 HF, S-65 TRAX	1
1258950	Ground Control Panel, S-60 XC, S-60 HF, S-60 TRAX	1
1263542	Label – Compartment Access	2
1272242	Label – Machine Registration/Owner Transfer	1
1278542	Label – Contact Alarm Weight (option)	1
1278567	Platform Control Panel	1
1278982	Label – Actuator Switch Socket (option)	1
1281169	Label – Recovery Switch	1
1281175	Label – Lanyard Anchorage Point, Fall Restrained	8
1281187	Label – Emergency Lowering, S-60 XC, S-60 HF, S-60 TRAX	1
1281188	Label – Emergency Lowering, S-65 XC, S-65 HF, S-65 TRAX	1
1284097	Label – Wheel Load	4
1284098	Label – Danger – Tip-over Hazard, S-65 XC, S-65 TRAX	1
1284099	Warning – Runaway Machine Hazard	1
1284103	Label – Danger – Tip-over Hazard, S-60 XC, S-60 TRAX	1
1284982	Warning – Explosion Hazard, Accumulator	1
1286362	Label – Crush Hazard, Service	2
1287489	Label – Wheel Load, S-60 XC	4
1289514	Label – Track Load, S-60 TRAX	4
1287515	Label – Track Load, S-65 TRAX	4
1287590	Label – Transport and Lifting	2
1293616	Label – Danger – Tip-over Hazard, S-65 HF	1
1293617	Label – Danger – Tip-over Hazard, S-60 HF	1
1294340	Warning – Runaway Machine Hazard, S-60 HF, S-65 HF	1

 Shading indicates decal is hidden from view, i.e. under covers

* These decals are model, option or configuration specific.

Inspections

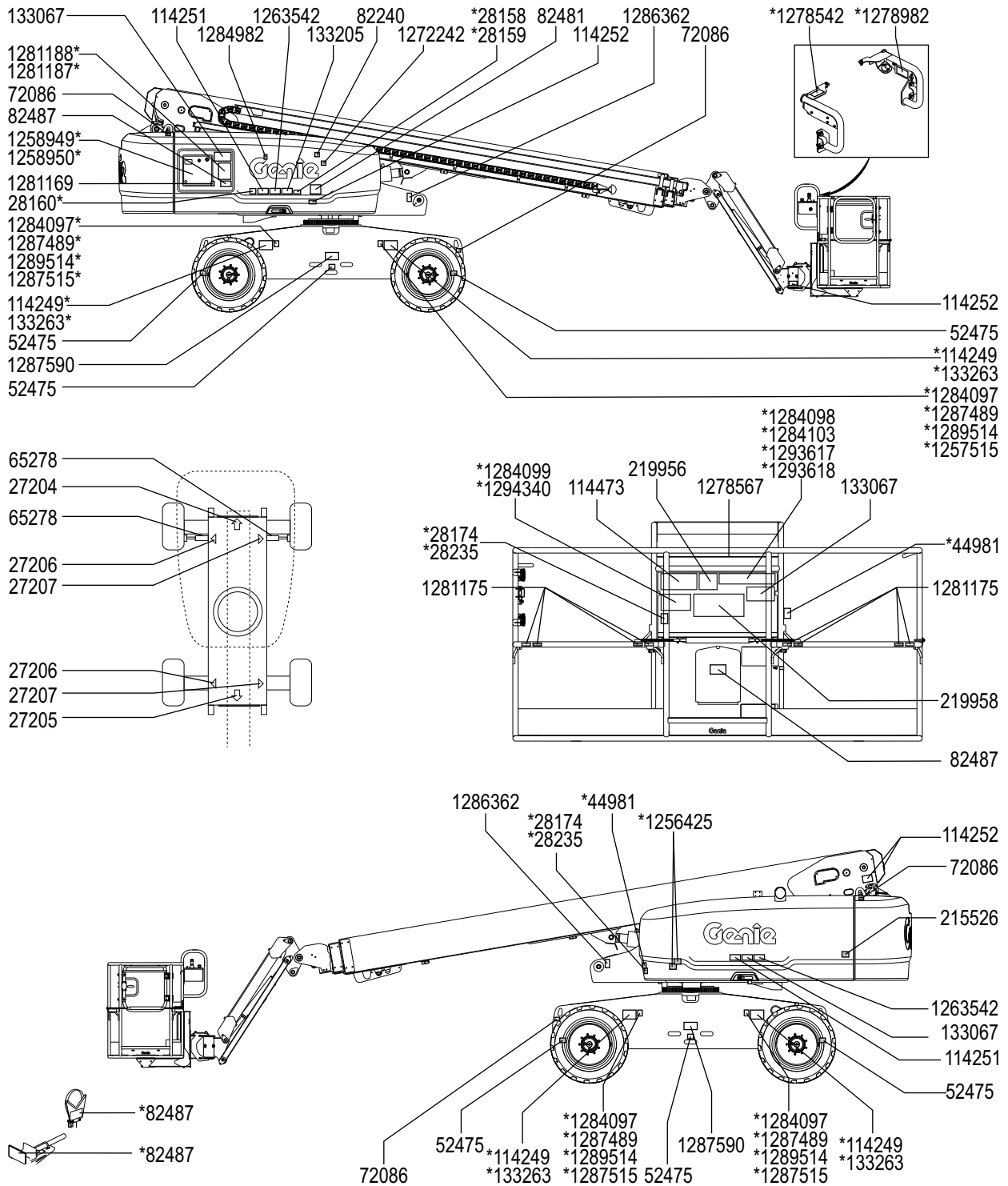

Operating Instructions

Pictures in this manual may show a boom with tires and wheels instead of tracks. All safety information and operating instructions still apply to the S-60 TRAX and the S-65 TRAX, even if the picture does not show the tracks.



Do Not Operate Unless:

- You learn and practice the principles of safe machine operation contained in this operator's manual.
 - 1 Avoid hazardous situations.
 - 2 Always perform a pre-operation inspection.
 - 3 Always perform function tests prior to use.
 - 4 Inspect the workplace.
 - 5 **Only use the machine as it was intended.**

Fundamentals

The Operating Instructions section provides instructions for each aspect of machine operation. It is the operator's responsibility to follow all the safety rules and instructions in the operator's, safety, and responsibilities manuals.

Using the machine for anything other than lifting personnel, along with their tools and materials, to an aerial work site is unsafe and dangerous.

Only trained and authorized personnel should be permitted to operate a machine. If more than one operator is expected to use a machine at different times in the same work shift, they must all be qualified operators and are all expected to follow all safety rules and instructions in the operator's, safety, and responsibilities manuals. That means every new operator should perform a pre-operation inspection, function tests, and a workplace inspection before using the machine.

Operating Instructions

Starting the Engine

Diesel models

- 1 At the ground controls, turn the key switch to the desired position.
- 2 Be sure both ground and platform control red Emergency Stop buttons are pulled out to the on position.
The engine glow plugs will automatically start when the machine is turned on.
- 3 At the ground controls: The LCD screen will display the glow plug symbol when the automatic glow plugs are on. 
- 4 At the platform controls: The glow plug indicator light will come on when the automatic glow plugs are on.
- 5 When the glow plugs turn off, start the engine. Move and hold the engine start toggle switch or press and hold the engine start button.
- 6 If the engine fails to start or dies, the restart delay will disable the start switch for 3 seconds.

Emergency Stop

Push in the red Emergency Stop button to the off position at the ground controls or the platform controls to stop all machine functions and turn the engine off.

Repair any function that operates when either red Emergency Stop button is pushed in.

Selecting and operating the ground controls will override the platform red Emergency Stop button.

Emergency Power

Use emergency power if the primary power source (engine) fails.

- 1 Turn the key switch to ground or platform control.
- 2 Pull out the red Emergency Stop button to the on position.
- 3 Press down the foot switch when using the controls from the platform.
- 4 Simultaneously push the emergency power button and activate the desired function. 

The drive function will not operate with emergency power.

Operating Instructions

Operation from Ground

- 1 Turn the key switch to ground control.
- 2 Pull out the red Emergency Stop button to the on position.
- 3 Diesel models: The engine glow plugs will automatically start when the machine is turned on.
- 4 When the glow plugs turn off, start the engine.

To Position Platform

- 1 Push and hold the function enable button.



- 2 Push the appropriate function button according to the markings on the control panel.

Drive and steer functions are not available from the ground controls.

Platform Overload Indicator Light

Light flashing indicates the platform is overloaded. The engine will stop and no functions will operate.

Remove weight from the platform until the light goes off and then restart the engine.

Note: An alarm will sound at the platform when an overload condition occurs and will stop sounding when weight is removed from the platform.

Operation from Platform

- 1 Turn the key switch to platform control.
- 2 Pull out both ground and platform red Emergency Stop buttons to the on position.
- 3 Diesel models: The engine glow plugs will automatically start when the machine is turned on.
- 4 When the glow plugs turn off, start the engine. Do not press down the foot switch when starting the engine.

To Position Platform

- 1 Press down the foot switch.
- 2 Slowly move the appropriate function control handle or toggle switch or press the appropriate button according to the markings on the control panel.

Note: When the boom is positioned at the edge of the operating envelope, boom down and boom retract are coordinated by the control system. The boom may retract while operating the boom down function.

Operating Instructions

To Steer

- 1 Press down the foot switch.
- 2 Slowly move the drive control handle in the direction indicated by blue or yellow triangles OR press the thumb rocker switch located on top of the drive control handle.

Use the color-coded direction arrows on the platform controls and the drive chassis to identify the direction the wheels or tracks will turn.

To Drive

- 1 Press down the foot switch.
- 2 Increase speed: Slowly move the control handle off center.

Decrease speed: Slowly move the control handle toward center.

Stop: Return the control handle to center or release the function enable switch.

Use the color-coded direction arrows on the platform controls and the drive chassis to identify the direction the machine will travel.

Machine travel speed is restricted when the boom is raised.

▲ Driving on a slope

Determine the uphill, downhill and side slope ratings for the machine and determine the slope grade.



Maximum slope rating, platform downhill (gradeability):

S-60/65 XC and S-60/65 TRAX

4WD: 45% (24°)

S-60/65 HF

4WD: 40% (22°)



Maximum slope rating, platform uphill:

S-60/65 XC and S-60/65 TRAX

4WD: 30% (17°)

S-60/65 HF

4WD: 25% (14°)



Maximum side slope rating:

S-60/65 XC, S-60/65 TRAX and S-60/65 HF

25% (14°)

Note: Slope rating is subject to ground conditions with one person in the platform and adequate traction. Additional platform weight may reduce slope rating. The term gradeability applies to the counterweight uphill configuration only.

Be sure the boom is below horizontal and the platform is between the non-steer wheels, or non-steer tracks.

Move the drive speed select switch to machine on incline symbol.

Operating Instructions

To determine the slope grade:

Measure the slope with a digital inclinometer OR use the following procedure.

You will need:

- carpenter's level
- straight piece of wood, at least 1 m long
- tape measure

Lay the piece of wood on the slope.

At the downhill end, lay the level on the top edge of the piece of wood and lift the end until the piece of wood is level.

While holding the piece of wood level, measure the vertical distance from the bottom of the piece of wood to the ground.

Divide the tape measure distance (rise) by the length of the piece of wood (run) and multiply by 100.

Example:

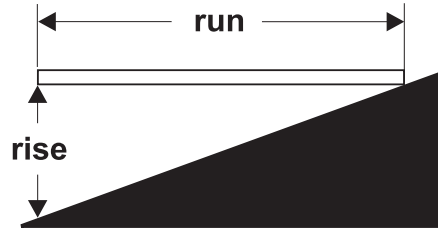

Piece of wood = 3.6 m

Run = 3.6 m

Rise = 0.3 m

$0.3 \text{ m} \div 3.6 \text{ m} = 0.083 \times 100 = 8.3\% \text{ grade}$

If the slope exceeds the maximum uphill, downhill or side slope rating, then the machine must be winched or transported up or down the slope. See Transport and Lifting section.

Operating Instructions

Drive Enable

Light flashing indicates that the boom has moved just past either non-steer wheel, or non-steer track and the drive function has been interrupted.



To drive, hold the drive enable switch to either side and slowly move the drive control handle off center.

Be aware that the machine may move in the opposite direction that the drive and steer controls are moved.

Always use the color-coded direction arrows on the platform controls and the drive chassis to identify the direction the machine will travel.

Drive Speed Select



- Machine on incline symbol: Low range operation for inclines or rough terrain
- Machine on level surface symbol: High range operation for maximum drive speed

Engine RPM Select

Select engine RPM using the symbols on the control panel.

When the foot switch is not pressed, the engine will idle at the lowest rpm.

- Turtle symbol: Foot switch activated low speed
- Rabbit symbol: Foot switch activated high speed

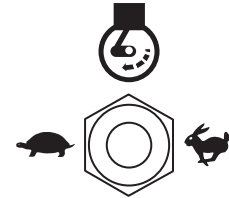

Generator (if equipped)

To operate the generator, move the generator toggle switch to the on position.

Note: The generator indicator light will turn on.

The generator will turn on and the engine will continue to run in high RPM mode.

Plug a power tool into AC power outlet located at the platform, or turntable.

To stop the generator, move the generator toggle switch to the off position.

Note: The generator indicator light will turn off and the RPM will return to normal.

Operating Instructions

Operating Envelope Indicator Lights

The operating envelope indicator lights will come on to notify the operator that a function has been interrupted and/or an action is required by the operator.

Raise/Retract Boom indicator light flashing: Raise/retract the boom until the indicator light is off.

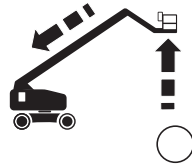

Lower Boom indicator light flashing: Lower the boom until the indicator light is off.

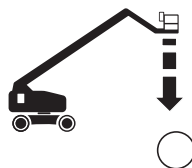

Machine On Incline indicator light is on: The light is on and the tilt alarm sounds when the machine exceeds the tilt sensor activation settings. Follow the appropriate procedure below and move the machine to a firm, level surface.

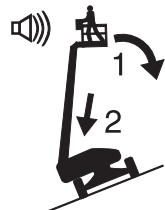

If the tilt alarm sounds with the platform uphill:

- 1 Lower the boom.
- 2 Retract the boom.

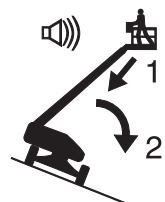

If the tilt alarm sounds with the platform downhill:

- 1 Retract the boom.
- 2 Lower the boom.

Platform Overload Indicator Light



Light flashing indicates the platform is overloaded. The engine will stop and no functions will operate.

Remove weight from the platform until the light goes off and then restart the engine.

Machine Malfunction Indicator Light



Light on indicates a system fault.

- 1 Push in and then pull out the red Emergency Stop button.
- 2 Lower and retract the boom.
- 3 Tag the machine and remove from service. Functions will not operate.

Operating Instructions

Platform Capacity Range

Range of motion is controlled automatically based on platform load.

S-60 XC, S-65 XC, S-60 TRAX, S-65 TRAX
 Unrestricted Range of Motion: When the platform load is less than 300 kg.

S-60 HF, S-65 HF Unrestricted Range of Motion:
 When the platform load is less than 272 kg, the restricted range of motion light is on.

S-60 XC, S-65 XC, S-60 TRAX, S-65 TRAX
 Restricted Range of Motion: When the platform load is 301-454 kg.

S-60 HF, S-65 HF Restricted Range of Motion:
 When the platform load is 272 - 454 kg.

S-60 XC and S-60 TRAX Range of Motion Chart

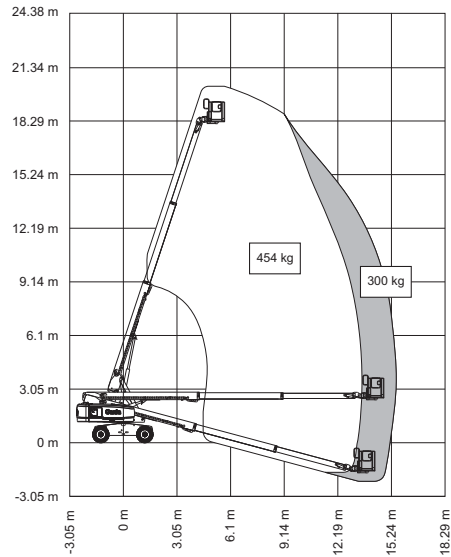

S-65 XC and S-65 TRAX Range of Motion Chart

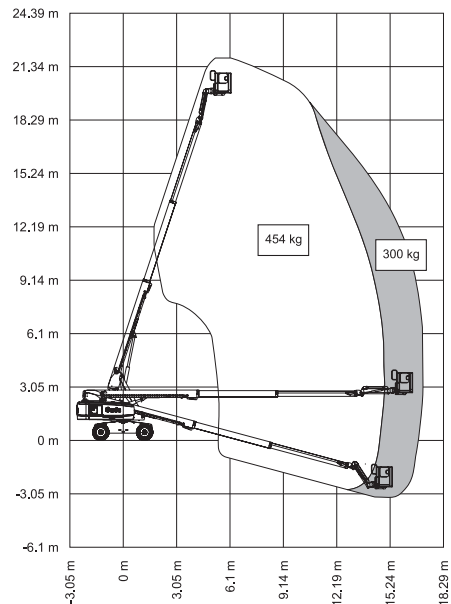

Operating Instructions

S-60 HF Range of Motion Chart

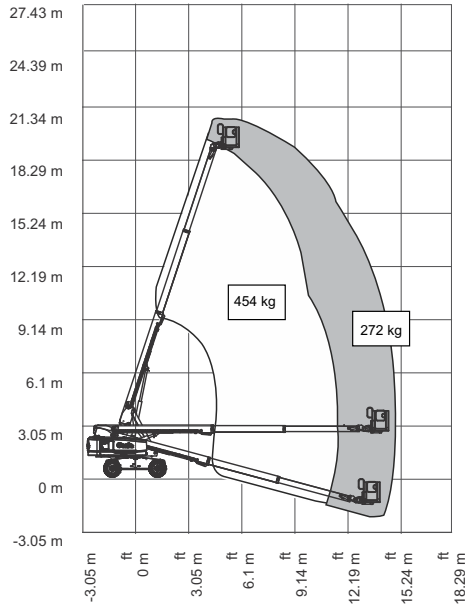

S-65 HF Range of Motion Chart

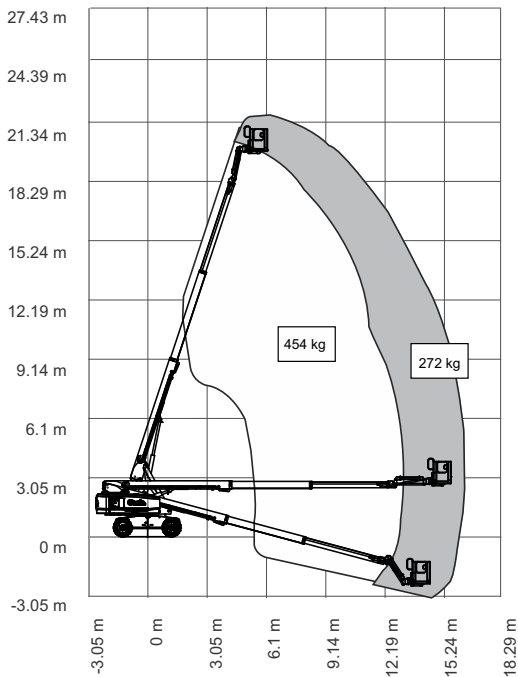

Tilt Sensor Activation Settings

S-60 XC, S-65 XC, S-60 TRAX, S-65 TRAX

Model	Tilt/Slope (front to back)	Maximum Boom Angle/ Platform Load	
		300 kg	454 kg
S-60 XC and S-60 TRAX	4°	71.7°	71.7°
	7°	51.1°	N/A
S-65 XC and S-65 TRAX	3°	71.7°	71.7°
	7°	51.1°	N/A

Model	Tilt/Slope (front to back)	Maximum Platform Height/ Platform Load	
		300 kg	454 kg
S-60 XC and S-60 TRAX	4°	18.28 m	18.28 m
	7°	14.51 m	N/A
S-65 XC and S-65 TRAX	3°	19.81 m	19.81 m
	7°	16.09 m	N/A

Model	Tilt/Slope (front to back)	Maximum Platform Reach/ Platform Load	
		300 kg	454 kg
S-60 XC and S-60 TRAX	4°	14.81 m	12.8 m
	7°	12.8 m	N/A
S-65 XC and S-65 TRAX	3°	16.51 m	14.32 m
	7°	14.32 m	N/A

Operating Instructions

S-60 HF, S-65 HF

Model	Tilt/Slope (front to back)	Maximum Boom Angle/ Platform Load	
		272 kg	454 kg
S-60 HF	0°	71°	71.7°
	4°	51°	53°
	7°	31°	N/A
S-65 HF	0°	71°	71°
	4°	41°	43°
	7°	14°	N/A

Model	Tilt/Slope (front to back)	Maximum Platform Height/ Platform Load	
		272 kg	454 kg
S-60 HF	0°	18.34 m	18.34 m°
	4°	17.5 m	14.73 m
	7°	13.7 m	N/A
S-65 HF	0°	19.86 m	19.86 m
	4°	18.01 m	15.6 m
	7°	15.06 m	N/A

Model	Tilt/Slope (front to back)	Maximum Platform Reach/ Platform Load	
		272 kg	454 kg
S-60 HF	0°	14.2 m	11.58 m°
	4°	12.7 m	10.36 m
	7°	10.36 m	N/A
S-65 HF	0°	15.6 m	13.11 m
	4°	14.22 m	11.89 m
	7°	11.89 m	N/A

S-60 XC, S-65 XC, S-60 TRAX, S-65 TRAX: The range of motion light is on when the platform load exceeds 300kg.



S-60 HF, S-65 HF: The range of motion light is on when the platform load exceeds 272 kg.

Light on indicates restricted range of motion due to platform weight.

S-60 XC, S-65 XC, S-60 TRAX, S-65 TRAX: The range of motion light is on when the platform load is less than 300 kg and on a slope



S-60 HF, S-65 HF: The range of motion light is on when the platform load is less than 272 kg and on a slope.

Light on indicates restricted range of motion due to platform weight and slope angle.

Note: When the Machine On Incline indicator light is on and the tilt alarm sounds, the following functions are affected; drive and lift up functions are disabled. Follow the Operator Envelope Indicator Lights procedure to restore drive and lift functions.



Operating Instructions

LCD Screen

The LCD screen at the ground controls displays hour meter, voltage, oil pressure and coolant temperature. The screen also displays fault codes and other service information.

Contact Alarm (if equipped)

The contact alarm is designed to alert ground personnel when an operator makes contact with the platform control panel, interrupting boom movement, sounding an alarm and flashing warning lights.

When the contact alarm cable is tripped, the lift and drive functions are disabled at the platform. The audio and visual warnings will activate alerting others that assistance may be needed. These notifications will continue until the system is reset.

- 1 The contact alarm cable is tripped, releasing the actuator from the switch socket.
- 2 Insert the actuator into the switch socket to turn off flashing lights and audio alarm.

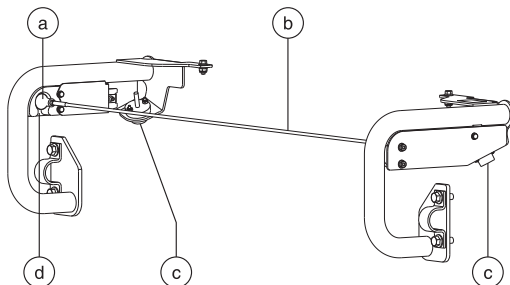

- a actuator
- b contact alarm cable
- c flashing alarm
- d switch socket

Aircraft Protection Package (if equipped)

If the platform bumpers come into contact with aircraft components, the machine will shut down and no functions will operate.

- 1 Start the engine.
- 2 Press down the foot switch.
- 3 Move and hold the aircraft protection function override switch.
- 4 Move the appropriate function control handle or toggle switch to move the machine away from aircraft components.

After Each Use

- 1 Select a safe parking location—firm level surface, clear of obstruction and traffic.
- 2 Retract and lower the boom to the stowed position.
- 3 Rotate the turntable so that the boom is between the non-steer wheels, or non-steer tracks.
- 4 Turn the key switch to the off position and remove the key to secure from unauthorized use.

Operating Instructions

Pipe Cradle Instructions

The pipe cradle assembly consists of 2 pipe cradles positioned at either side of the platform and mounted to the guardrails with U-bolts.

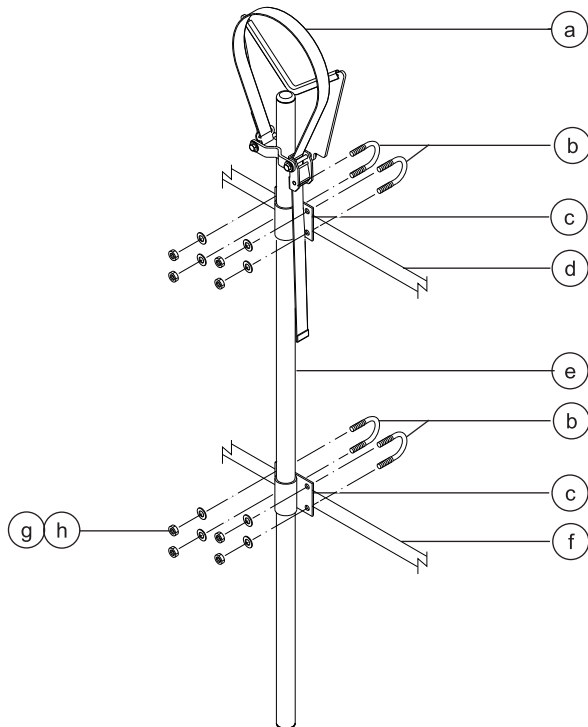

- a strap
- b U-bolts
- c pipe cradle mount
- d upper platform railing
- e pipe cradle weldment
- f middle platform railing
- g flat washers
- h nylock nuts

Observe and Obey:

- Pipe cradles must be installed on the inside of the platform.
- Pipe cradles must not obstruct the platform controls or the platform entrance.
- The bottom of the pipe cradle tube must rest on the platform floor.
- Be sure the platform is level before installing a pipe cradle.

Pipe Cradle Installation

- 1 Install a pipe cradle on each side of the platform. Refer to the illustration on the left. Make sure the bottom of the pipe cradle tube rests on the platform floor.
- 2 Install two U-bolts from the outside of the platform rails through each pipe cradle mount.
- 3 Secure each U-bolt with 2 washers and 2 nuts.

Operating Instructions

Pipe Cradle Operation

- 1 Be sure the pipe cradle assembly and installation instructions have been followed properly and that the pipe cradles are secured to the platform railings.
 - 2 Place the load so that it rests in both pipe cradles. The length of the load should be parallel with the length of the platform.
 - 3 Center the load in the pipe cradles.
 - 4 Secure the load to each pipe cradle. Pass the nylon strap over the load. Depress the buckle and slide the strap through. Tighten the strap.
 - 5 Gently push and pull on the load to make sure the pipe cradles and load are secure.
 - 6 Keep the load secured when the machine is moving.
- ▲ Tip-over hazard. The weight of the pipe cradle assembly and the load in the pipe cradles will reduce the rated platform capacity of the machine and must be factored into the total platform load.
- ▲ Tip-over hazard. The weight of the pipe cradle assembly and the load in the pipe cradles may limit the maximum number of occupants in the platform.

Maximum Pipe Cradle Capacity

All models	90.7 kg
Pipe Cradle Assembly Weight	9.5 kg

Panel Cradle Assembly

- 1 Apply the warning decal to the front of each panel cradle (if needed).
- 2 Install rubber bumper 1 in the panel cradle base. See the illustration.
- 3 Secure the bumper with 2 high profile lock nuts and 2 washers.

Panel Cradle Installation

- 1 Insert the hook piece through the slots in the panel cradle base.
- 2 Hook the panel cradle to the bottom platform tube in the desired location.
- 3 Install rubber bumper 2 through the panel cradle base and the hook piece. See the illustration.
- 4 Secure with 2 low profile lock nuts.
- 5 If the panel cradle is installed at a platform floor support tube, insert the U-bolt through the floor, around the tube and into the panel cradle base.
- 6 Secure the U-bolt with 2 nuts and 2 washers. Proceed to step 9.
- 7 If the panel cradle is not installed at a platform floor support tube, use the aluminum tube provided.
- 8 Place the tube between the panel cradle and the platform floor. Insert the U-bolt through the floor, around the tube and into the panel cradle base.
- 9 Repeat above for the second set of parts.

Operating Instructions

Installation of Padding

- 1 Install the 2 pieces of padding on the platform rails. Position the padding to protect the panels from contact with the platform rails.

Installation of Strap

- 1 Open the clamp and install it around a vertical platform rail tube.
- 2 Insert a bolt with a washer through one side of the clamp.
- 3 Install the strap assembly end plate onto the bolt.
- 4 Insert the bolt through the other side of the clamp.
- 5 Secure with a washer and a nut. Do not over-tighten. The strap assembly end plate should be able to slide on the platform rail.

Panel Cradle Operation

- 1 Secure both panel cradles to the platform.
- 2 Place the load so that it rests in both panel cradles.
- 3 Center the load on the platform.
- 4 Secure the load to the platform using the strap. Tighten the strap.

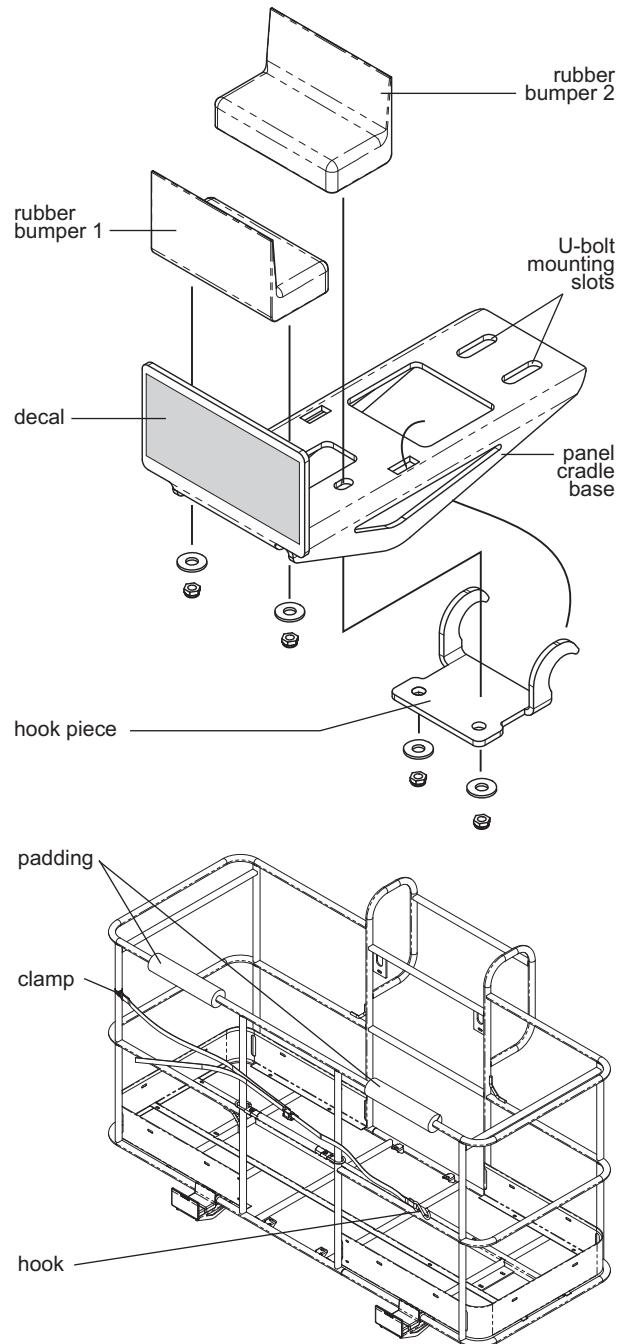

Transport and Lifting Instructions

Pictures in this manual may show a boom with tires and wheels instead of tracks. All safety information and operating instructions still apply to the S-60 TRAX and the S-65 TRAX, even if the picture does not show the tracks.



Observe and Obey:

- ☑ Genie provides this securement information as a recommendation. Drivers are solely responsible for making sure machines are properly secured and the correct trailer is selected pursuant to US Department of Transportation regulations, other localized regulations, and their company policy.
 - ☑ Genie customers needing to containerize any lift or Genie product should source a qualified freight forwarder with expertise in preparing, loading and securing construction and lifting equipment for international shipment.
 - ☑ Only qualified mobile elevating work platform operators should move the machine on, or off the truck.
 - ☑ The transport vehicle must be parked on a level surface.
 - ☑ The transport vehicle must be secured to prevent rolling while the machine is being loaded.
 - ☑ Be sure the vehicle capacity, loading surfaces and chains or straps are sufficient to withstand the machine weight. Genie lifts are very heavy relative to their size. See the serial label for the machine weight.
- ☑ Be sure the turntable is secured with the turntable rotation lock before transporting. Be sure to unlock the turntable for operation.
 - ☑ Do not drive the machine on a slope that exceeds the uphill, downhill or side slope rating. See Driving on a Slope in the Operating Instructions section.
 - ☑ If the slope of the transport vehicle bed exceeds the maximum slope rating, the machine must be loaded and unloaded using a winch as described in the brake release operation.

Free-wheel Configuration for Winching

Chock the wheels or tracks to prevent the machine from rolling.

Release the wheel or track brakes by turning over all four drive hub disconnect caps.

Be sure the winch line is properly secured to the drive chassis tie points and the path is clear of all obstructions.

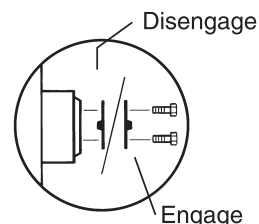

Reverse the procedures described to re-engage the brakes.

Note: The pump free-wheel valve should always remain closed.

Transport and Lifting Instructions

Securing to Truck or Trailer for Transit

Always use the turntable rotation lock pin each time the machine is transported.

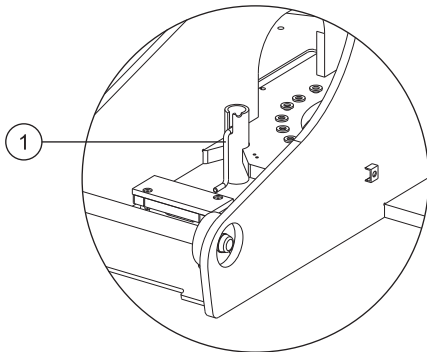

1 Turntable rotation lock pin

Turn the key switch to the off position and remove the key before transporting.

Inspect the entire machine for loose or unsecured items.

Securing the Chassis

Use chains of ample load capacity.

Use a minimum of 6 chains.

Adjust the rigging to prevent damage to the chains.

For diagram, refer to the Lifting Instructions.

Securing the Platform – S-60 XC, S-60 HF and S-60 TRAX

Make sure the platform is in the stowed position.

Secure the platform with a nylon strap placed parallel to the strap guides. Do not use excessive downward force when securing the boom section.

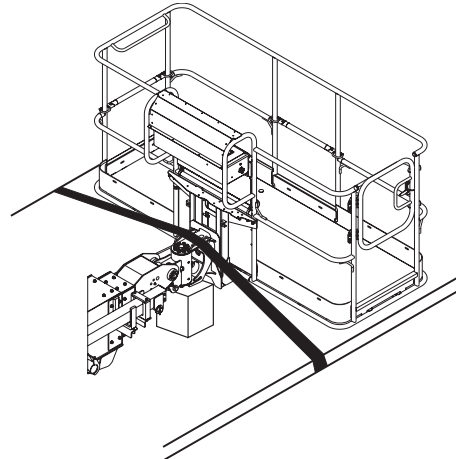

Securing the Platform – S-65 XC, S-65 HF and S-65 TRAX

Make sure the jib and platform are in the stowed position.

Secure the platform with a nylon strap placed parallel to the strap guides. Do not use excessive downward force when securing the boom section.

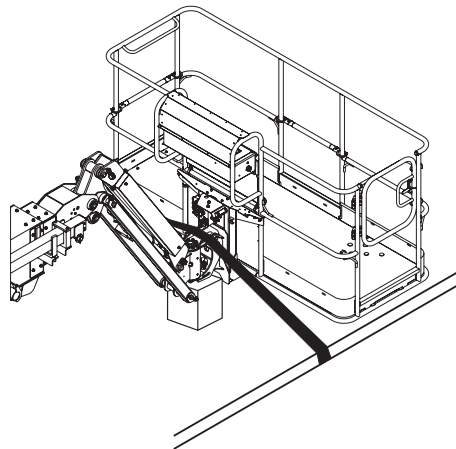

Transport and Lifting Instructions



Observe and Obey:

- ☑ Only qualified riggers should rig the machine.
- ☑ Only certified crane operators should lift the machine and only in accordance with the applicable crane regulations.
- ☑ Be sure the crane capacity, loading surfaces and straps or lines are sufficient to withstand the machine weight. See the serial label for the machine weight.

Lifting Instructions

Fully lower and retract the boom. Fully lower the jib. (if equipped)

Determine the center of gravity of your machine using the table and the picture on this page.

Attach the rigging only to the designated lifting points on the machine. All four of the lifting points are on the turntable.

Adjust the rigging to prevent damage to the machine and to keep the machine level.

Center of gravity	X Axis	Y Axis
S-60 XC	1.73 m	1.3 m
S-65 XC	1.76 m	1.36 m
S-60 TRAX	1.68 m	1.17 m
S-65 TRAX	1.73 m	1.24 m
S-60 HF	1.73 m	1.35 m
S-65 HF	1.77 m	1.42 m

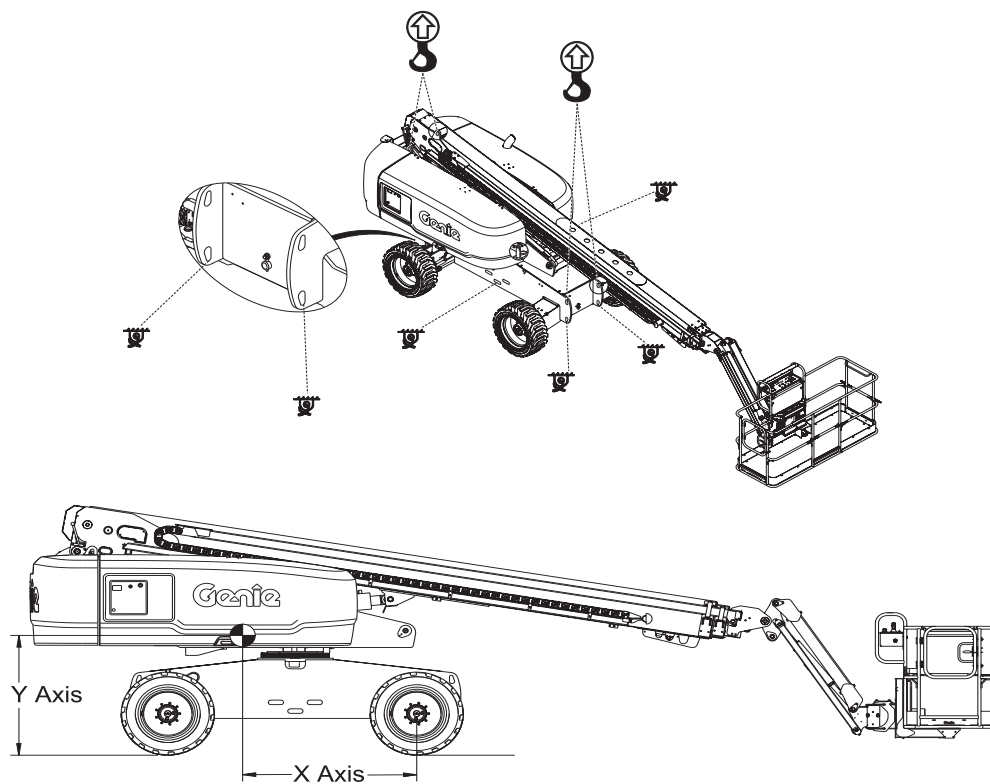

Maintenance



Observe and Obey:

- ☑ Only routine maintenance items specified in this manual shall be performed by the operator.
- ☑ Scheduled maintenance inspections shall be completed by qualified service technicians, according to the manufacturer's specifications and the requirements specified in the responsibilities manual.
- ☑ Dispose of material in accordance with governmental regulations.
- ☑ Use only Genie approved replacement parts.

Maintenance Symbols Legend

The following symbols have been used in this manual to help communicate the intent of the instructions. When one or more of the symbols appear at the beginning of a maintenance procedure, it conveys the meaning below.



Indicates that tools will be required to perform this procedure.



Indicates that new parts will be required to perform this procedure.



Indicates that a cold engine is required before performing this procedure.

Check the Engine Oil Level



Maintaining the proper engine oil level is essential to good engine performance and service life. Operating the machine with an improper oil level can damage engine components.

Note: Check the oil level with the engine off.

- 1 Check the oil level dipstick. Add oil as needed.

Deutz 2011 L03i Engine

Oil type	15W-40
Oil type - cold conditions	5W-40

Deutz TD2.9 Engine

Oil type	15W-40
Oil type - cold conditions	5W-30

Diesel Fuel Requirements



Satisfactory engine performance is dependent on the use of a good quality fuel. The use of a good quality fuel will give the following result: long engine life and acceptable exhaust emissions levels.

Minimum diesel fuel requirements for each engine are listed below.

Deutz 2011 L03i Engine

Fuel Type	Low Sulfur Diesel (LSD)
-----------	-------------------------

Deutz TD2.9 Engine

Fuel Type	Low Sulfur Diesel (LSD)
-----------	-------------------------

Maintenance

Check the Hydraulic Oil Level



Maintaining the hydraulic oil at the proper level is essential to machine operation. Improper hydraulic oil levels can damage hydraulic components. Daily checks allow the inspector to identify changes in oil level that might indicate the presence of hydraulic system problems.

- 1 Be sure that the boom is in the stowed position.
- 2 Visually inspect the sight gauge located on the side of the hydraulic oil tank.
- ⊙ Result: The hydraulic oil level should be within the top 5 cm of the sight gauge.
- 3 Add oil as needed. Do not overfill.

Hydraulic oil specifications

Hydraulic oil type	Chevron Rando HD equivalent
--------------------	-----------------------------

Check the Engine Coolant Level – Liquid Cooled Models



Maintaining the engine coolant at the proper level is essential to engine service life. Improper coolant level will affect the engine's cooling capability and damage engine components. Daily checks will allow the inspector to identify changes in coolant level that might indicate cooling system problems.

- ▲ Burn hazard. Beware of hot engine parts and coolant. Contact with hot engine parts and/or coolant may cause severe burns.
 - ▲ Burn hazard. Do not remove the radiator cap if the engine has been running. Contact with pressurized coolant may cause severe burns. Allow engine to cool before removing the radiator cap.
- 1 Check the fluid level in the coolant recovery tank. Add fluid as needed.
 - ⊙ Result: The fluid level should be at the FULL mark on the tank or visible in the sight gauge.

Maintenance

Check the Batteries



Proper battery condition is essential to good machine performance and operational safety. Improper fluid levels or damaged cables and connections can result in component damage and hazardous conditions.

- ▲ **Electrocution hazard.** Contact with hot or live circuits may result in death or serious injury. Remove all rings, watches and other jewelry.
 - ▲ **Bodily injury hazard.** Batteries contain acid. Avoid spilling or contacting battery acid. Neutralize battery acid spills with baking soda and water.
- 1 Put on protective clothing and eye wear.
 - 2 Be sure that the battery cable connections are tight and free of corrosion.
 - 3 Be sure that the battery hold-down brackets are in place and secure.

Note: Adding terminal protectors and a corrosion preventative sealant will help eliminate the corrosion on the battery terminals and cables.

Scheduled Maintenance

Maintenance performed quarterly, annually and every two years must be completed by a person trained and qualified to perform maintenance on this machine according to the procedures found in the service and maintenance manuals for this machine.

Machines that have been out of service for more than three months must receive the quarterly inspection before they are put back into service.

Specifications

Model	S-60 XC
Height, working maximum	20.29 m
Height, platform maximum	18.29 m
Horizontal reach, platform maximum	14.8 m
Maximum load capacity	300 kg
Maximum load capacity, restricted	454 kg
Maximum wind speed	12.5 m/s
Platform rotation	160°
Platform leveling	self-leveling
Turntable rotation (degrees)	360° continuous
Turntable tailswing	1.41 m
Height, stowed maximum	2.8 m
Length, stowed	8.71 m
Width, standard tires	2.49 m
Wheelbase	2.49 m
Ground clearance, center	41.4 cm
Ground clearance, axle	25.4 cm
Turning radius (inside)	2.4 m
Turning radius (outside)	5.5 m
Platform dimensions, 6 foot (length x width)	183 cm x 76 cm
Platform dimensions, 8 foot (length x width)	244 cm x 91 cm
Controls	12V DC proportional
AC outlet in platform	standard
System voltage	12V
Hydraulic pressure, maximum (boom functions)	207 bar
Tire size	355/55D 625
Fuel tank capacity	132 liters
Hydraulic tank capacity	151 liters
Weight	10,401 kg
(Machine weights vary with option configurations. See serial label for specific machine weight.)	
Ambient operating temperature	-20° F to 120° F -29° C to 49° C

Airborne noise emissions

Sound pressure level at ground workstation	83 dBA
Sound pressure level at platform workstation	79 dBA
Guaranteed sound power level	105 dBA
Total vibration value to which the hand/arm system is subjected does not exceed 2.5 m/s ² .	

Highest root mean square value of weighted acceleration to which the whole body is subjected does not exceed 0.5 m/s².

Maximum slope rating, stowed position, 4WD

Platform uphill	30% (17°)
Platform downhill	45% (24°)
Side slope	25% (14°)

Note: Slope rating is subject to ground conditions with one person in the platform and adequate traction. Additional platform weight may reduce slope rating.

Drive speeds

Drive speed, stowed	4.8 km/h 12.2 m/9.1 sec
Drive speed, raised or extended	1.1 km/h 12.2 m/40 sec

Floor loading information

Tire load maximum	5,790 kg
Tire contact pressure	6.3 kg/cm ² 620 kPa
Occupied floor pressure	1,371 kg/m ² 13.44 kPa

Note: Floor loading information is approximate and does not incorporate different option configurations. It should be used only with adequate safety factors.

Continuous improvement of our products is a Genie policy. Product specifications are subject to change without notice or obligation.

Specifications

Model	S-65 XC
Height, working maximum	21.81 m
Height, platform maximum	19.81 m
Horizontal reach, platform maximum	16.51 m
Maximum load capacity	300 kg
Maximum load capacity, restricted	454 kg
Maximum wind speed	12.5 m/s
Platform rotation	160°
Platform leveling	self-leveling
Turntable rotation (degrees)	360° continuous
Turntable tailswing	1.41 m
Height, stowed maximum	2.82 m
Length, stowed	9.76 m
Width, standard tires	2.49 m
Wheelbase	2.49 m
Ground clearance, center	41.4 cm
Ground clearance, axle	25.4 cm
Turning radius (inside)	2.4 m
Turning radius (outside)	5.5 m
Platform dimensions, 6 foot (length x width)	183 cm x 76 cm
Platform dimensions, 8 foot (length x width)	244 cm x 91 cm
Controls	12V DC proportional
AC outlet in platform	standard
System voltage	12V
Hydraulic pressure, maximum (boom functions)	207 bar
Tire size	355/55D 625
Fuel tank capacity	132 liters
Hydraulic tank capacity	151 liters
Weight	11,412 kg
(Machine weights vary with option configurations. See serial label for specific machine weight.)	
Ambient operating temperature	-20° F to 120° F -29° C to 49° C

Airborne noise emissions

Sound pressure level at ground workstation	83 dBA
Sound pressure level at platform workstation	79 dBA
Guaranteed sound power level	105 dBA

Total vibration value to which the hand/arm system is subjected does not exceed 2.5 m/s².

Highest root mean square value of weighted acceleration to which the whole body is subjected does not exceed 0.5 m/s².

Maximum slope rating, stowed position, 4WD

Platform uphill	30% (17°)
Platform downhill	45% (24°)
Side slope	25% (14°)

Note: Slope rating is subject to ground conditions with one person in the platform and adequate traction. Additional platform weight may reduce slope rating.

Drive speeds

Drive speed, stowed	4.8 km/h 12.2 m/9.1 sec
Drive speed, raised or extended	1.1 km/h 12.2 m/40 sec

Floor loading information

Tire load maximum	6,100 kg
Tire contact pressure	6.3 kg/cm ² 620 kPa
Occupied floor pressure	1,483 kg/m ² 14.55 kPa

Note: Floor loading information is approximate and does not incorporate different option configurations. It should be used only with adequate safety factors.

Continuous improvement of our products is a Genie policy. Product specifications are subject to change without notice or obligation.

Specifications

Model	S-60 TRAX
Height, working maximum	20.29 m
Height, platform maximum	18.29 m
Horizontal reach, platform maximum	14.8 m
Maximum load capacity	300 kg
Maximum load capacity, restricted	454 kg
Maximum wind speed	12.5 m/s
Platform rotation	160°
Platform leveling	self-leveling
Turntable rotation (degrees)	360° continuous
Turntable tailswing	1.37 m
Height, stowed maximum	2.8 m
Length, stowed	8.71 m
Width, TRAX	2.58 m
Wheelbase	2.5 m
Ground clearance, center	41.4 cm
Ground clearance, axle	25.4 cm
Turning radius (inside)	3.48 m
Turning radius (outside)	6.5 m
Platform dimensions, 6 foot (length x width)	183 cm x 76 cm
Platform dimensions, 8 foot (length x width)	244 cm x 91 cm
Controls	12V DC proportional
AC outlet in platform	standard
System voltage	12V
Hydraulic pressure, maximum (boom functions)	207 bar
Fuel tank capacity	132 liters
Hydraulic tank capacity	151 liters
Weight	12,174 kg
(Machine weights vary with option configurations. See serial label for specific machine weight.)	
Ambient operating temperature	-20° F to 120° F -29° C to 49° C

Airborne noise emissions	
Sound pressure level at ground workstation	83 dBA
Sound pressure level at platform workstation	79 dBA
Guaranteed sound power level	105 dBA

Total vibration value to which the hand/arm system is subjected does not exceed 2.5 m/s².

Highest root mean square value of weighted acceleration to which the whole body is subjected does not exceed 0.5 m/s².

Maximum slope rating, stowed position, 4WD

Platform uphill	30% (17°)
Platform downhill	45% (24°)
Side slope	25% (14°)

Note: Slope rating is subject to ground conditions with one person in the platform and adequate traction. Additional platform weight may reduce slope rating.

Drive speeds

Drive speed, stowed	3.7 km/h 12.2 m/12 sec
Drive speed, raised or extended	0.7 km/h 12.2 m/60 sec

Floor loading information

Track load maximum	6,176 kg
Track contact pressure	1.61 kg/cm ² 158 kPa
Occupied floor pressure	1,297 kg/m ² 12.72 kPa

Note: Floor loading information is approximate and does not incorporate different option configurations. It should be used only with adequate safety factors.

Continuous improvement of our products is a Genie policy. Product specifications are subject to change without notice or obligation.

Specifications

Model	S-65 TRAX
Height, working maximum	21.81 m
Height, platform maximum	19.81 m
Horizontal reach, platform maximum	16.51 m
Maximum load capacity	300 kg
Maximum load capacity, restricted	454 kg
Maximum wind speed	12.5 m/s
Platform rotation	160°
Platform leveling	self-leveling
Turntable rotation (degrees)	360° continuous
Turntable tailswing	1.37 m
Height, stowed maximum	2.81 m
Length, stowed	9.76 m
Width, TRAX	2.58 m
Wheelbase	2.5 m
Ground clearance, center	41.4 cm
Ground clearance, axle	25.4 cm
Turning radius (inside)	3.48 m
Turning radius (outside)	6.5 m
Platform dimensions, 6 foot (length x width)	183 cm x 76 cm
Platform dimensions, 8 foot (length x width)	244 cm x 91 cm
Controls	12V DC proportional
AC outlet in platform	standard
System voltage	12V
Hydraulic pressure, maximum (boom functions)	207 bar
Fuel tank capacity	132 liters
Hydraulic tank capacity	151 liters
Weight	13,154 kg
(Machine weights vary with option configurations. See serial label for specific machine weight.)	
Ambient operating temperature	-20° F to 120° F -29° C to 49° C

Maximum slope rating, stowed position, 4WD

Platform uphill	30% (17°)
Platform downhill	45% (24°)
Side slope	25% (14°)

Note: Slope rating is subject to ground conditions with one person in the platform and adequate traction. Additional platform weight may reduce slope rating.

Airborne noise emissions

Sound pressure level at ground workstation	83 dBA
Sound pressure level at platform workstation	79 dBA
Guaranteed sound power level	105 dBA

Total vibration value to which the hand/arm system is subjected does not exceed 2.5 m/s².

Highest root mean square value of weighted acceleration to which the whole body is subjected does not exceed 0.5 m/s².

Drive speeds

Drive speed, stowed	3.7 km/h 12.2 m/12 sec
Drive speed, raised or extended	0.7 km/h 12.2 m/61 sec

Floor loading information

Track load maximum	6,648 kg
Track contact pressure	1.76 kg/cm ² 170 kPa
Occupied floor pressure	1,392 kg/m ² 13.66 kPa

Note: Floor loading information is approximate and does not incorporate different option configurations. It should be used only with adequate safety factors.

Continuous improvement of our products is a Genie policy. Product specifications are subject to change without notice or obligation.



Specifications

Model	S-60 HF
Height, working maximum	20.33 m
Height, platform maximum	18.33 m
Horizontal reach, platform maximum	14.21 m
Maximum load capacity	272 kg
Maximum load capacity, restricted	454 kg
Maximum wind speed	12.5 m/s
Platform rotation	160°
Platform leveling	self-leveling
Turntable rotation (degrees)	360° continuous
Turntable tailswing	1.38 m
Height, stowed maximum	2.85 m
Length, stowed	8.71 m
Width, high flotation tires	2.55 m
Wheelbase	2.5 m
Ground clearance, center	44 cm
Ground clearance, axle	28 cm
Turning radius (inside)	3.29 m
Turning radius (outside)	5.57 m
Platform dimensions, 6 foot (length x width)	72 in x 30 in 183 cm x 76 cm
Platform dimensions, 8 foot (length x width)	96 in x 36 in 244 cm x 91 cm
Controls	12V DC Proportional
AC outlet in platform	standard
System voltage	12V
Hydraulic pressure, maximum (boom functions)	207 bar
Tire size	41/18LL x 22.5, 20 ply
Fuel tank capacity	132 liters
Hydraulic tank capacity	151 liters
Weight	10,081 kg
(Machine weights vary with option configurations. See serial label for specific machine weight.)	
Ambient operating temperature	-20° F to 120° F -29° C to 49° C

Airborne noise emissions

Sound pressure level at ground workstation	83 dBA
Sound pressure level at platform workstation	79 dBA
Guaranteed sound power level	105 dBA
Total vibration value to which the hand/arm system is subjected does not exceed 2.5 m/s ² .	
Highest root mean square value of weighted acceleration to which the whole body is subjected does not exceed 0.5 m/s ² .	

Maximum slope rating, stowed position, 4WD

Platform uphill	25% (14°)
Platform downhill	45% (24°)
Side slope	25% (14°)

Note: Slope rating is subject to ground conditions with one person in the platform and adequate traction. Additional platform weight may reduce slope rating.

Drive speeds

Drive speed, stowed	4.8 km/h 12.2 m/9.1 sec
Drive speed, raised or extended	0.7 km/h 12.2 m/61 sec

Floor loading information

Tire load maximum	5,445 kg
Tire contact pressure	7.03 kg/cm ² 690 kPa
Occupied floor pressure	1,268 kg/m ² 12.44 kPa

Note: Floor loading information is approximate and does not incorporate different option configurations. It should be used only with adequate safety factors.

Continuous improvement of our products is a Genie policy. Product specifications are subject to change without notice or obligation.

Specifications

Model	S-65 HF
Height, working maximum	21.86 m
Height, platform maximum	19.86 m
Horizontal reach, platform maximum	15.6 m
Maximum load capacity	272 kg
Maximum load capacity, restricted	454 kg
Maximum wind speed	12.5 m/s
Platform rotation	160°
Platform leveling	self-leveling
Turntable rotation (degrees)	360° continuous
Turntable tailswing	1.38 m
Height, stowed maximum	2.85 m
Length, stowed	9.76 m
Width, high flotation tires	2.55 m
Wheelbase	2.5 m
Ground clearance, center	44 cm
Ground clearance, axle	28 cm
Turning radius (inside)	3.29 m
Turning radius (outside)	5.57 m
Platform dimensions, 6 foot (length x width)	72 in x 30 in 183 cm x 76 cm
Platform dimensions, 8 foot (length x width)	96 in x 36 in 244 cm x 91 cm
Controls	12V DC Proportional
AC outlet in platform	standard
System voltage	12V
Hydraulic pressure, maximum (boom functions)	207 bar
Tire size	41/18LL x 22.5, 20 ply
Fuel tank capacity	132 liters
Hydraulic tank capacity	151 liters
Weight	11,092 kg
(Machine weights vary with option configurations. See serial label for specific machine weight.)	
Ambient operating temperature	-20° F to 120° F -29° C to 49° C

Airborne noise emissions

Sound pressure level at ground workstation	83 dBA
Sound pressure level at platform workstation	79 dBA
Guaranteed sound power level	105 dBA
Total vibration value to which the hand/arm system is subjected does not exceed 2.5 m/s ² .	
Highest root mean square value of weighted acceleration to which the whole body is subjected does not exceed 0.5 m/s ² .	

Maximum slope rating, stowed position, 4WD

Platform uphill	25% (14°)
Platform downhill	45% (24°)
Side slope	25% (14°)

Note: Slope rating is subject to ground conditions with one person in the platform and adequate traction. Additional platform weight may reduce slope rating.

Drive speeds

Drive speed, stowed	4.8 km/h 12.2 m/9.1 sec
Drive speed, raised or extended	0.7 km/h 12.2 m/61 sec

Floor loading information

Tire load maximum	5,824 kg
Tire contact pressure	7.03 kg/cm ² 690 kPa
Occupied floor pressure	1,373 kg/m ² 13.47 kPa

Note: Floor loading information is approximate and does not incorporate different option configurations. It should be used only with adequate safety factors.

Continuous improvement of our products is a Genie policy. Product specifications are subject to change without notice or obligation.

Specifications

S-60 XC and S-60 TRAX Range of Motion Chart

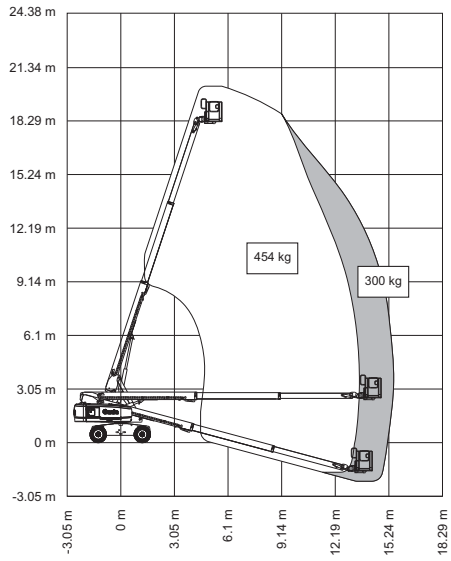

S-65 XC and S-65 TRAX Range of Motion Chart

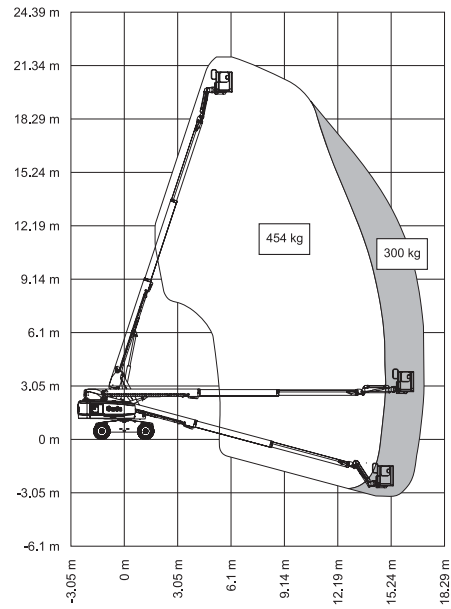

Specifications

S-60 HF Range of Motion Chart

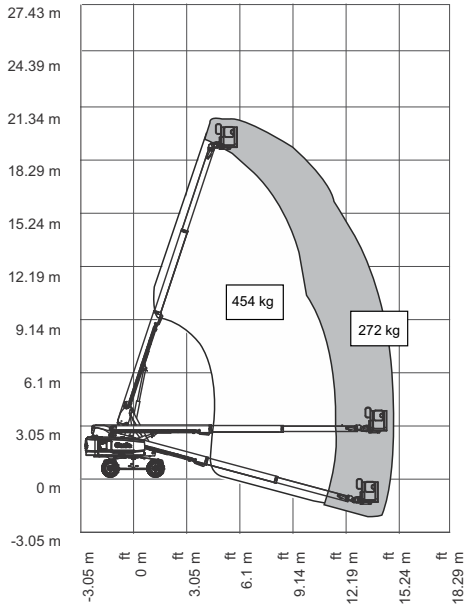

S-65 HF Range of Motion Chart

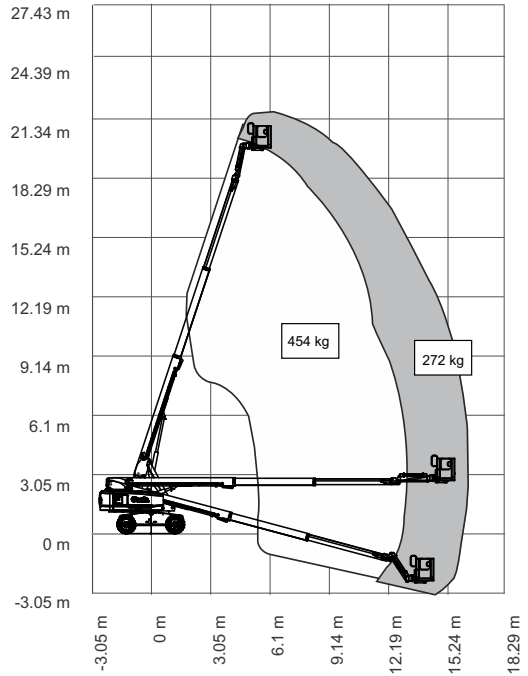

www.genielift.com

Distributed By: