



# Operation Manual

---

---

**SR0818D/SR1018D/SR1218D  
SR1023D/SR1323D/SR1623D**

**Mobile Elevating Work Platform**

## Warning

Before operation and maintenance, the drivers and service personnel shall always read and thoroughly understand all information in this manual. Failure to do so may result in, fatal accidents or personal injury.

This manual must be kept with this machine at all times.

# Mobile Elevating Work Platform Operation Manual

880\*1230 mm 16 format 8 printed sheets

Eighth edition and printed for the first time in May 2022

---

**Lingong Group Jinan Heavy Machinery Co., Ltd.**

Add: 12th Floor, Building 3, Lushanguoaocheng, 9777 Jingshi Road, Lixia District, Jinan, China

Tel: 86-0531-67605017

Fax: 86-0531-67605017

Technical service: 86-0531-67605017

Web: [www.LGMG.com.cn](http://www.LGMG.com.cn)

Accessories sales: 86-0531-67605016

# Contents

Contents.....	I
Chapter 1 Safety .....	1
1.1 Danger.....	3
1.2 No Operation Except Following Cases .....	3
1.3 Classification of Hazards .....	3
1.4 Intended purpose.....	3
1.5 Safety Sign Maintenance .....	3
1.6 Risk of Electric Shock .....	4
1.7 Safety of Work Area .....	4
1.8 Crushing Hazards .....	5
1.9 Hazards When Operating on a Slope .....	6
1.10 Falling Hazards.....	6
1.11 Crash Hazards .....	6
1.12 Hazard of Component Damage .....	7
1.13 Hazard of Explosion and Fire.....	7
1.14 Machine Damage Hazards .....	7
1.15 Personal Injury Hazards.....	7
1.16 Battery Safety .....	7
1.17 Tilting Hazard.....	8
1.18 Ground information .....	8
Chapter 2 Machine Nomenclature .....	9
Chapter 3 Decals and Warning Labels .....	13
Chapter 4 Specifications .....	23
Chapter 5 Control Station.....	87
5.1 Ground Control Station .....	89
5.2 PCU.....	97
5.3 Basic Operation .....	101
Chapter 6 Pre-Operation Check.....	113
6.1 No Operation Except Following Cases .....	115
6.2 Basic Principles .....	115
6.3 Check Before Operation .....	115
Chapter 7 Workplace Check.....	117
7.1 No Operation Is Allowed Unless.....	119
7.2 Basic Principles .....	119
7.3 Workplace Inspection.....	119
Chapter 8 Functional Test .....	121

---

8.1 No Operation Is Allowed Unless.....	123
8.2 Basic Principles .....	123
8.3 Functional Test.....	123
8.4 Test on the Ground Control Station .....	123
8.5 Platform Control Station Test .....	124
8.6 Tilt Sensor Operation Test.....	125
8.7 Upper Limit Switch and Outriggers (If Equipped) Test.....	125
Chapter 9 Operation Instructions.....	127
9.1 No Operation is Allowed Unless.....	129
9.2 Basic Principles .....	129
9.3 Emergency Stop .....	129
9.4 Engine startup .....	129
9.5 Operation from Ground.....	130
9.6 Operation from Platform.....	130
9.7 Drive on Slope .....	130
9.8 Platform Extension and Retraction.....	131
9.9 Emergency Descent .....	131
9.10 Using Platform Control Station to Operate on the Ground .....	131
9.11 Outrigger Operation .....	131
9.12 Safety Arm Use.....	132
9.13 Auxiliary Descent (If equipped).....	132
9.14 Fall Protection.....	132
9.15 DPF Regeneration .....	132
9.16 Low temperature start kit (If Equipped) .....	134
9.17 After Each Use.....	134
Chapter 10 Transportation and Lifting Instructions .....	135
10.1 Compliance.....	137
10.2 Securing on Trucks or Trailers During Transportation .....	137
10.3 Ensuring Transportation Safety.....	137
10.4 Lifting guidance.....	138
10.5 Freewheel configuration for trailers .....	138

## Foreword

Thank you for choosing to use this Mobile Elevating Work Platform from LGMG. This machine is designed according to EN280:2013/A1:2015. The information specified in this manual is intended for the safe and proper operation of this machine for its' intended purpose.

For maximum performance and utilization of this machine, thoroughly read and understand all the information in this manual before starting, operating, or performing maintenance on this machine.

Due to continuous product improvements, LGMG reserves the right to make specification changes without any prior notifications. For any updated information, contact LGMG.

Ensure all preventive maintenance to the machine is performed according to the interval specified in the maintenance schedule.

Keep this manual with this machine for reference at all times. When the ownership of this machine is transferred, this manual shall be transferred with this machine. This manual must be replaced immediately if it is lost, damaged, or becomes illegible.

This manual is copyrighted material. The reproduction or copy of this manual is not allowed without the written approval of LGMG.

The information, technical specifications and drawings in this manual are the latest available when this manual is issued. Due to continuous improvement, LGMG reserves the right to change the technical specifications and machine design without notice. If any specifications and information in the manual are not consistent with your machine, please contact the service department of LGMG.

### **WARNING**

**Only personnel who have been properly trained and qualified to operate or maintain this machine can operate, repair and maintain this machine.**

**Improper operation, maintenance, and repair are dangerous and can cause personal injury and death.**

**Before any operation or maintenance, the operator shall thoroughly read this manual. Do not operate, perform any maintenance or make any repairs on this machine before reading and understanding this manual.**

**The user shall load the platform strictly according to the load rating of the platform. Do not overload the platform or make any modifications to the platform without permission from LGMG.**

**The operation regulations and preventions in this manual are only applicable for the specified use of this machine.**

# Safety Precautions

The operator of this machine shall understand and follow the existing safety regulations of state and local governments. If these are unavailable, the safety instructions in this manual shall be followed.

To help prevent accidents, read and understand all warnings and precautions in this manual before operation or performing maintenance.

The safety measures are specified in Chapter 1 Safety.

It is impossible to foresee every possible hazard and the safety instructions in this manual may not cover all safety prevention measures. Always ensure the safety of all personnel and protect the machine against any damage. If unable to confirm the safety of some operations, contact LGMG.

The operation & maintenance prevention measures listed in this manual are only applicable to the specified uses of this machine. LGMG assumes no responsibility if this machine is used beyond the range of this manual. The user and the operator shall be responsible for the safety of such operations.

Do not perform any operation forbidden in this manual in any situation.

The following signal words are applicable for identifying the level of safety information in this manual.

 **Danger:**

**An imminent situation, that if not avoided, will result in severe injuries or death. This is also applicable to situations that will cause serious machine damage, if not avoided.**

 **Warning:**

**A potentially dangerous situation, that if not avoided, may result in severe injuries or death. This is also applicable to situations that may cause serious machine damage, if not avoided.**

 **Notice:**

**A situation, that if not avoided, may result in minor or intermediate injury. This is also applicable to situations that may cause machine damage or shorten machine service life.**

# Chapter 1 Safety





## 1.1 Danger

Failure to disobey the instructions and safety rules in this manual may cause death or serious injuries.

## 1.2 No Operation Except Following Cases

You have understood and practiced the rules for safe operation of the vehicle in this manual.

- 1) Avoid dangerous situations. Know and understand the safety rules before proceeding with the next step.
- 2) Always perform a pre-operation inspection.
- 3) Always perform a pre-use functional test.
- 4) Check the workplace.
- 5) Use the vehicle only for its intended purpose.
- 6) Read, understand, and follow the manufacturer's instructions and safety rules - safe operation manuals and vehicle labels.
- 7) Read, understand and follow user safety rules and work site regulations.
- 8) Read, understand and follow all applicable government laws and regulations.
- 9) You have received the training on safe operation of the vehicle.

## 1.3 Classification of Hazards



### Classification of hazards

The meanings of symbols, color codes and characters of LGMG's products are as follows:

**Security warning symbol:** are used for warning of potential personal injuries.

**Observe all safety instructions below these signs, to avoid situations causing potential personal injury and**

death.



**Red: Signifies dangerous situations. If not avoided, will result in personal death or severe injury.**



**Orange: Signifies dangerous situations. If not avoided, may result in personal death or severe injury.**



**Yellow: Signifies dangerous situations. If not avoided, may result in minor or intermediate personal injury.**



**Blue: Signifies dangerous situations. If not avoided, property loss or damage can occur.**

## 1.4 Intended purpose

The use of the machine is only limited to lift staff, tools and materials to the high work place.

 **Caution: It is forbidden to carry loads.**

## 1.5 Safety Sign Maintenance

- 1) The operators should always keep in mind their safety when replacing any missing or damaged safety signs.
- 2) The safety decal should be cleaned with

mild soap and water.

- 3) Do not use solvent-based cleaners as they may damage the material of the safety label.

## 1.6 Risk of Electric Shock

- 1) This machine is not insulated and is not provided with electrical shock protection when it comes into contact with or near electrical wire.

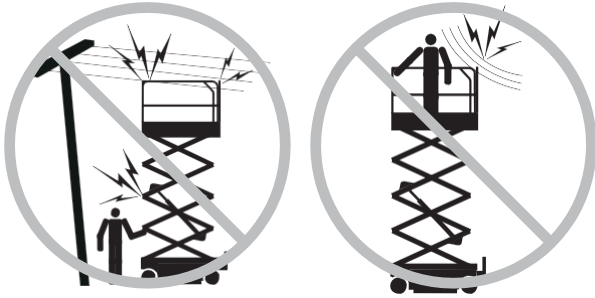

- 2) This machine should be kept an adequate safety distance from power line and electrical equipment according to applicable government laws and regulations and the following table.

Voltage	Required safety distance
0V-50 KV	3.05m/10ft
50 KV-200 KV	4.60m/15ft
200 KV-350 KV	6.10m/20ft
350 KV-500 KV	7.62m/25ft
500 KV-750 KV	10.67m/35ft
750 KV-1,000 KV	13.72m/45ft

- 3) The effects of strong winds or gusts on the movement of the platform, the swinging and slackening of the wires should be considered.
- 4) If the machine comes into contact with live wires, keep away from the vehicle. No one is allowed to touch or operate the vehicle on the ground or platform before cutting off the power supply.
- 5) Do not operate the machine when there is lightning or storms.
- 6) Do not use the machine as a ground wire during welding.

## 1.7 Safety of Work Area

- 1) The platform can only be raised on a solid and flat level ground.

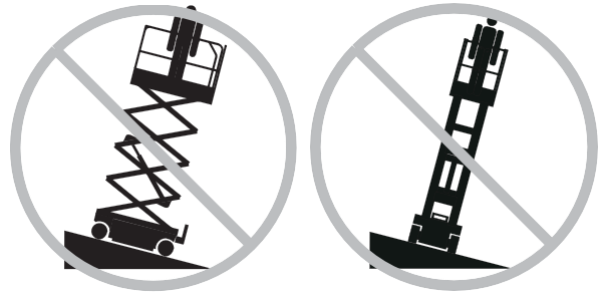

- 2) The speed shall not exceed 1.1km/h (SR1023D/SR1323D/SR1623D)/0.5 km/h (SR0818D/SR1018D/SR1218D) when the platform is raised.
- 3) The tilt alarm cannot be regarded as level indicator. When the machine is seriously inclined, the tilt alarm of the chassis and platform will ring.
- 4) If tilt alarm sounds, lower the platform and move the machine to solid level ground. If the tilt alarm rings when the platform is raised, the platform shall be lowered very carefully.
- 5) Do not operate the machine in strong winds or gusts. The surface area of the platform or load cannot be increased. Increasing the area exposed to the wind will reduce the stability of the machine.
- 6) If the machine is used outdoors, do not elevate the platform when wind speed is above 12.5 m/s. If wind speed exceeds the limit after elevating the platform, immediately lower the platform and stop all machine operation.

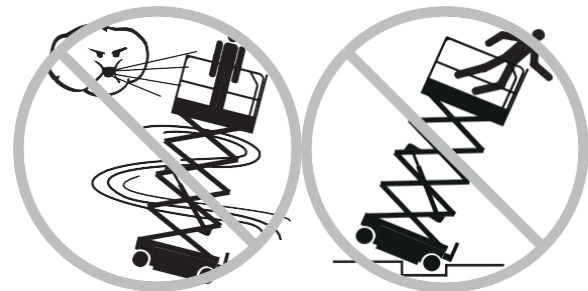

- 7) In the elevated state of the platform, the machine cannot run on uneven terrain, an unstable surface, or in other dangerous situations, or near these areas.

- 8) In the stowed state, the machine must run very carefully and reduce its speed when it runs on uneven terrain, unstable or smooth surface with stones, or near holes, or a steep slope.
- 9) Do not drive in high-speed descending any slope.
- 10) Do not use the platform control station to release the platform when the platform is tilted, stuck, or its normal operation is obstructed by other nearby obstacles. Before using the ground control station to release the platform, all personnel must exit the platform.
- 11) Do not use the platform to push or pull anything outside the platform.



- 12) Do not use the machine as a crane.
- 13) Do not place, fasten and fix or suspend loads on any component of the machine.



- 14) Do not place ladders or scaffolds within the platform or against any component of the machine.
- 15) Do not attach platforms to adjacent buildings.
- 16) Do not change or disable limit switch.
- 17) Do not tie platforms to adjacent components.
- 18) Do not place loads outside the platform guardrail.
- 19) Do not change or damage any component

that may affect the safety and stability of the machine.

- 20) Do not replace key parts that affect machine stability with parts of different weights or specifications.
- 21) Do not change or modify the aerial work platform or install additional equipment for placing tools or other materials on platforms, pedals or guardrails, which will increase platform weight and surface area or load.
- 22) Do not push machines or other objects with the platform.
- 23) Tools and materials, evenly distributed and able to be safely moved by the operator in the platform, can be carried in the platform only.
- 24) Do not use the machine on a movable surface or vehicle.
- 25) Keep all tires in good condition and appropriately tighten the lug nuts.
- 26) Ambient temperature for machine operation is -20°C-40°C.
- 27) The allowable fluctuation of machine power supply voltage is ±10%.

## 1.8 Crushing Hazards

- 1) Do not place arms, hands, or fingers in any position where there is a hazard of potential crushing by the machine's scissors.
- 2) Do not place your hands in a position where you may get pinched when folding the guardrail.
- 3) Grasp the platform guardrail all the time when removing the pins fixed on the guardrail. Do not let the platform guard rail fall off.
- 4) When the machine is being driven from the ground using the controller, use good judgment and carefully plan the travel path. Keep a safe distance between the operator, machine and any fixed objects, walls, or buildings.

## 1.9 Hazards When Operating on a Slope

Do not drive the machine on a slope that exceeds the slope and side slope rating of the machine. The rated value of slope is applicable to a stowed machine.

Model	Maximum slope rating, stowed position	Maximum side slope rating, stowed position
SR1023D	40%	40%
SR1323D		
SR1623D		
SR0818D (Without outrigger)		
SR0818D (With outrigger)	35%	35%
SR1018D		
SR1218D		

## 1.10 Falling Hazards

- 1) All workers in the platform must use approved safety harnesses and attach the lanyard to the provided anchor points in the platform. Each anchor point is limited to one lanyard.

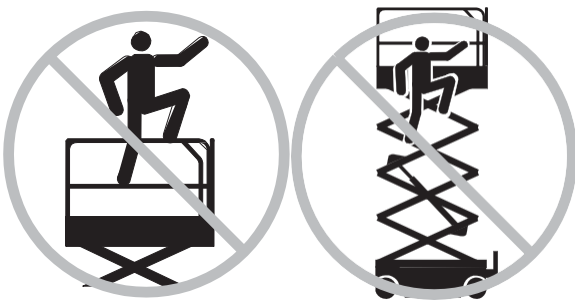

- 2) Do not climb on or sit on the guard rail of the platform. Firmly stand on the platform floor at all times.
- 3) Do not climb down the platform scissors

when the machine is elevated.

- 4) Keep the platform floor free from debris.
- 5) Shut the platform door before operation.
- 6) Do not operate the machine if the guard rail is not correctly installed.
- 7) Do not enter or exit the platform unless the machine is in the stowed position.

## 1.11 Crash Hazards

- 1) Pay attention to any items or obstacles within the machine's sight line and in any blind spots when starting or running the machine.
- 2) Pay attention to the position of the extending platform when moving the machine.
- 3) Check the workstation to avoid any overhead barriers or other possible hazards in the work site.
- 4) Pay attention to any crushing hazards when holding the guard rail of the platform.
- 5) The operator must follow the manufacturer's service rules for personal protection equipment, the service rules for the workstation, and the laws and regulations made by the local government.
- 6) Observe and follow the traveling arrow and the turning direction arrows on the platform controller and the platform's label and nameplate.
- 7) Do not operate the machine on the line of any crane or movable overhead machine, unless the crane controller is locked and/or the potential bump prevention measure is taken.
- 8) Dangerous driving or careless operation when running the machine are strictly prohibited.
- 9) The platform can be lowered only when there are no personnel or barriers below the platform.



- 10) Limit travel speed according to ground conditions, traffic, road grade, personnel position, or any other possible bump factors.
- 11) It is recommended the operator wear a qualified safety helmet when operating the machine.

## 1.12 Hazard of Component

### Damage

- 1) Do not use any battery or charger greater than 12 V to start up the engine.
- 2) Do not use the machine as a ground for welding.
- 3) Do not use the machine in a place where there may be a magnetic field.

## 1.13 Hazard of Explosion and

### Fire

- 1) Do not use the machine in a hazardous place where there may be inflammable or explosive gas or particles.
- 2) Do not start the engine if liquefied petroleum gas (LPG), gasoline, diesel or other explosive substances are smelled or perceived.
- 3) Do not refuel the machine when the engine is running.
- 4) Refuel the machine or charge the battery only in open and well-ventilated places far away from sparks, open flames, burning cigarettes, etc.

## 1.14 Machine Damage

### Hazards

- 1) Do not use a damaged or malfunctioning machine.

- 2) Make a complete operational and function check before each shift. Attach a tag on a damaged or malfunctioning machine immediately and stop all operation.
- 3) Be sure to perform all maintenance and operation according to the instructions in this manual.
- 4) Be sure to keep all labels and decals at the appropriate locations. Replace any that are not legible.
- 5) Be sure to keep this manual in the manual box of the platform.

## 1.15 Personal Injury Hazards

- 1) Do not operate the machine if it is leaking hydraulic oil. Leaking hydraulic oil under pressure can pierce or burn skin.
- 2) Always operate the machine in a well-ventilated place to avoid poisoning of carbon monoxide.
- 3) Severe injury may result if any component below the cover is touched by mistake. Only trained technicians can perform maintenance to the components under the cover. The operator shall only perform maintenance before the pre-operation inspection. Be sure to keep all compartments closed and locked during operation of the machine.

## 1.16 Battery Safety

### Combustion Hazards

- 1) The battery contains acid. Wear protective clothing and safety goggles when performing maintenance on the battery.
- 2) Take measures to prevent acid from overflowing out of the battery or being touched. Neutralize the overflowed acid material from the battery with soda and water.

### Explosion Hazard

- 1) Keep the battery away from any sparks or open flames. The battery can release an explosive gas.
- 2) Do not touch the battery terminal or the cables with any tool that may cause a

spark.

- 3) If the machine is parked for a long time, disconnect the main power switch.

**Electric Shock/Burn Hazard**

Avoid contacting electrical terminals.

**1.17 Tilting Hazard**

- 1) The outrigger can only be lowered on the firm, stable ground. Be careful to avoid steep slopes, holes, unstable or smooth slopes and other potential hazards.
- 2) Be sure to lower the outrigger at the steering end first, when the automatic leveling function is not used and a single outrigger is lowered.
- 3) Raise the platform only when the machine is level. Do not set the machine to be elevated when it is impossible to make the machine level by outrigger only.
- 4) When all four legs are lowered in close contact with the ground and the machine is level, raise the platform. (if equipped)
- 5) Do not adjust outriggers when the platform is elevated. Do not drive the vehicle when outriggers are lowered.

**1.18 Ground information**



**WARNING: Rollover and personal**

**injury will be caused under severe working conditions and complex and unsafe ground conditions, and stable ground conditions and good working conditions can ensure the normal operation of the machine; therefore before operation, verify that the ground in the working area is safe and strong enough to support the machine.**



**DANGER: Rollover and personal**

**injury may occur under the following conditions:**

- on steep slopes or in caves;
- when there are protrusions, obstacles or debris on the ground;
- on the inclined surface;
- on the unstable or smooth surface;
- near the mining area where the soil foundation is soft soil;
- on saturated soil or frozen soil;
- on suspended floor;
- on kerbs and road edges;
- on surface support that is not strong enough to withstand the full load of the machine;
- under other possible unsafe situations.

The ground load bearing information of the machine is shown in the table below:

Model	Tire contact pressure (kPa)	Ground pressure of tire (kPa)	Ground pressure of outrigger (kPa)
SR0818D	490.41	9.91	8.12
SR1018D	524.48	8.71	7.13
SR1218D	575.46	7.97	6.53
SR1023D	887.37	9.33	7.68
SR1323D	887.71	9.66	7.96
SR1623D	888.31	10.25	8.45



**CAUTION: The ground load**

**bearing information given herein is for reference only, and does not consider the optional devices of the machine. Before using the machine, always verify that the ground of the working area is safe and strong enough to support the machine.**

## **Chapter 2 Machine Nomenclature**





SR0818D/SR1018D/SR1218D

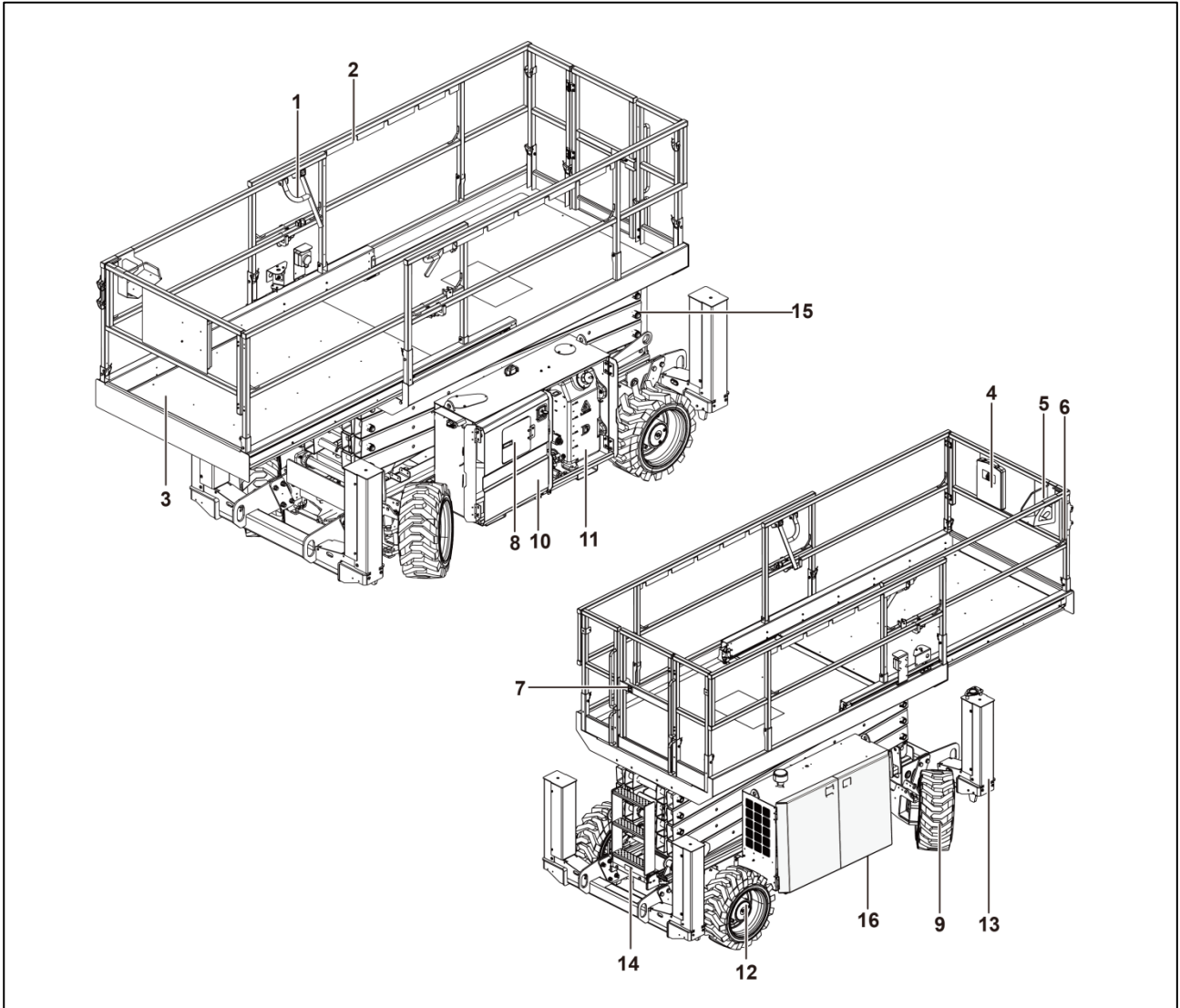

No.	Name	No.	Name
1	Platform Extension Locking Handle	9	Steering Wheel
2	Platform Guard Rails	10	Hydraulic Oil Tank
3	Extension Platform	11	Fuel Tank
4	Document Box	12	Non-Steering Wheel
5	Platform Control Station	13	Outrigger(If Equipped)
6	Lanyard Anchorage Points	14	Ladder
7	Platform Entrance Door	15	Scissor Stack Arm
8	Ground Control Station	16	Engine Side

SR1023D/SR1323D/SR1623D

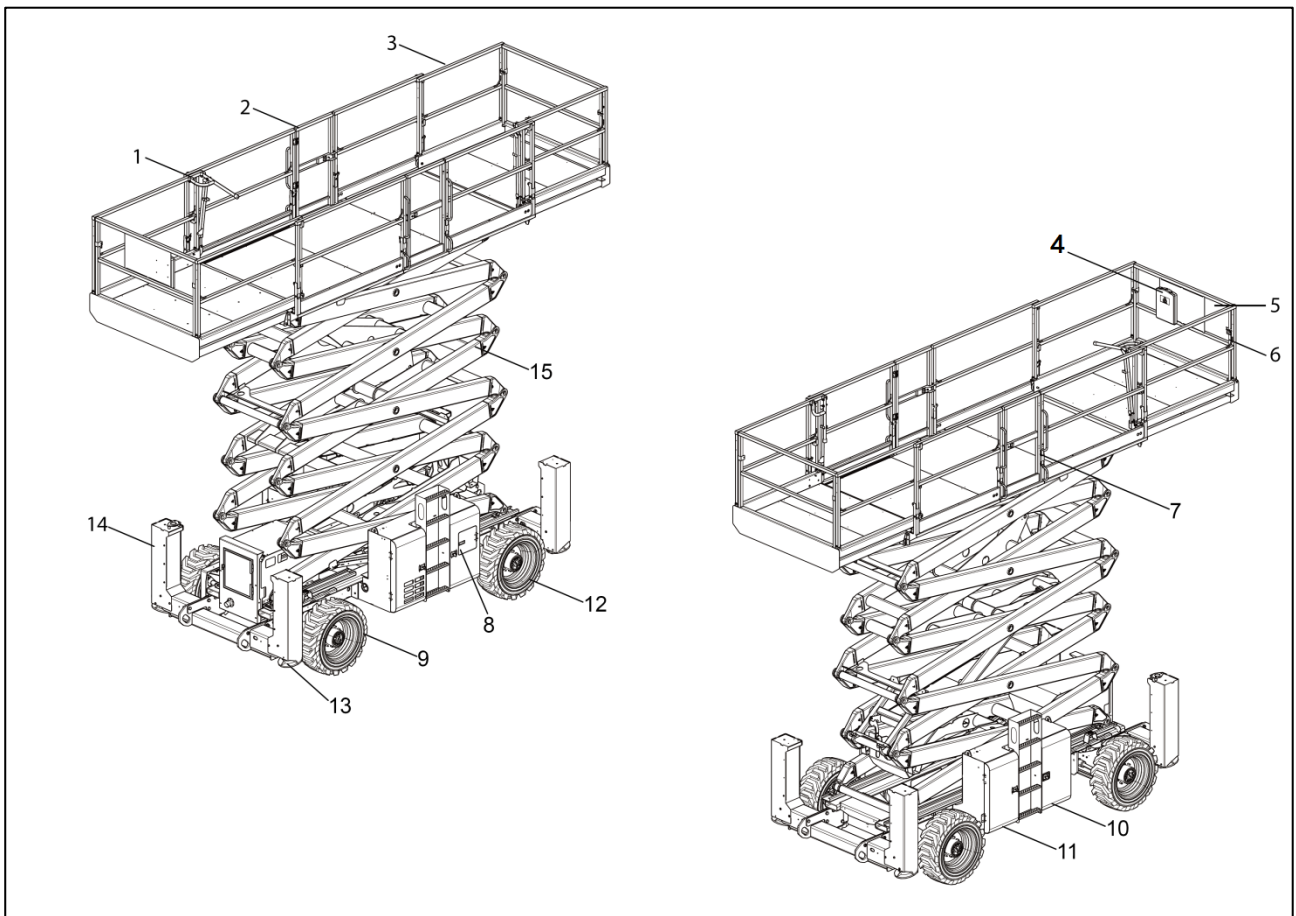

No.	Name	No.	Name
1	Platform Extension Locking Handle	9	Steering Wheel
2	Platform Guard Rails	10	Hydraulic Oil Tank
3	Extension Platform	11	Fuel Tank
4	Document Box	12	Non-Steering Wheel
5	Platform Control Station	13	Outrigger Foot Pad(If Equipped)
6	Lanyard Anchorage Points	14	Outrigger Bracket(If Equipped)
7	Platform Entrance Door	15	Scissor Stack Arm
8	Ground Control Station		

## **Chapter 3 Decals and Warning Labels**



SR0818D/SR1018D/SR1218D Decals Diagram

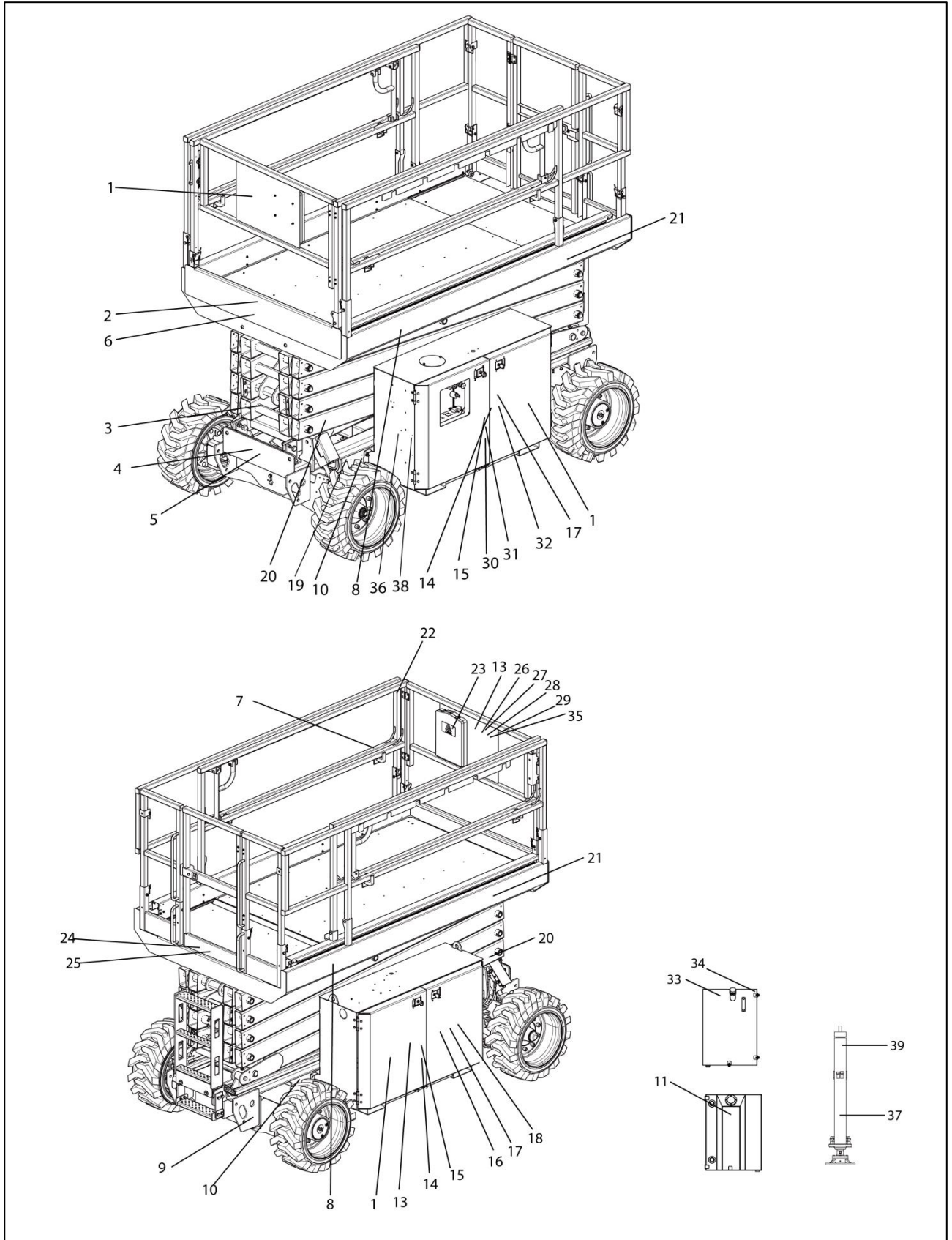

SR0818D/SR1018D/SR1218D Decals List

Code	Name	Code	Name
1	Company Logo	20	Stay away from machine sign
2	IPAF	21	Model identification
3	Forklift safety arm sign	22	Pressure hazard identification
4	Hazard mark of tipping	23	Instructions
5	Fasting of transport parts	24	Rated load mark
6	Warning line	25	Maximum manual power
7	Lanyard Anchorage Point	26	Danger-Outrigger Safety and Instructions
8	Company Logo	27	Prohibition sign
9	Hanger sign	28	Reduce platform warning sign
10	Wheel load capacity sign	29	Hazard mark of tipping
11	Fuel tank sign	30	Emergency lowering mark
12	Whole machine nameplate	31	CE
13	Danger description	32	Warning description
14	Attention in overhaul	33	Hydraulic oil tank sign
15	Hazard mark of smashing and pressing	34	Hydraulic oil level signs
16	Explosion burn warning sign	35	Indicator mark of direction arrow
17	Electric shock hazard	36	Turn off the power
18	Attention mark of skin infraction	37	Outrigger load
19	Direction indicator sign	38	Identification of power switch
		39	Decal-Ground check

## SR0818D/SR1018D/SR1218D Decals

1-2534000220	2-2534000272	3-2534000032	4-2534000015	5-2534001173	6-2534000024
7-2534000017	8-2534000218	9-2831990027	10-2534001922	11-2534000177	12-2534000773
13-2534001166	14-2534000011	15-2534000022	16-2534000004	17-2534000009	18-2534000029
19-2534000102	20-2534000019	21-2534002502/1646/1645	22-2534000173	23-2534000119	24-2534000390/10032504
		<b>SR0818D</b> <b>SR1018D</b> <b>SR1218D</b>			
25-2534000179	26-2534000791	27-2534000229	28-2534000013	29-2534000172	30-2534000034
31-2534000276	32-2534000145	33-2534001995	34-2534001377	35-2534000033	36-2534002181

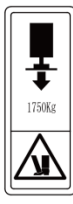
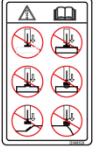
37-2534002158	38-2534002026	39-2534003526			
	<p><b>NOTICE</b></p> <p><b>Battery disconnect switch</b></p> <p>1 Cut off the power when the machine is repaired or not used for long period.</p> <p>2 Stop the engine/turn the main switch off after two minutes.</p>				



SR1023D/SR1323D/SR1623D Decals Diagram

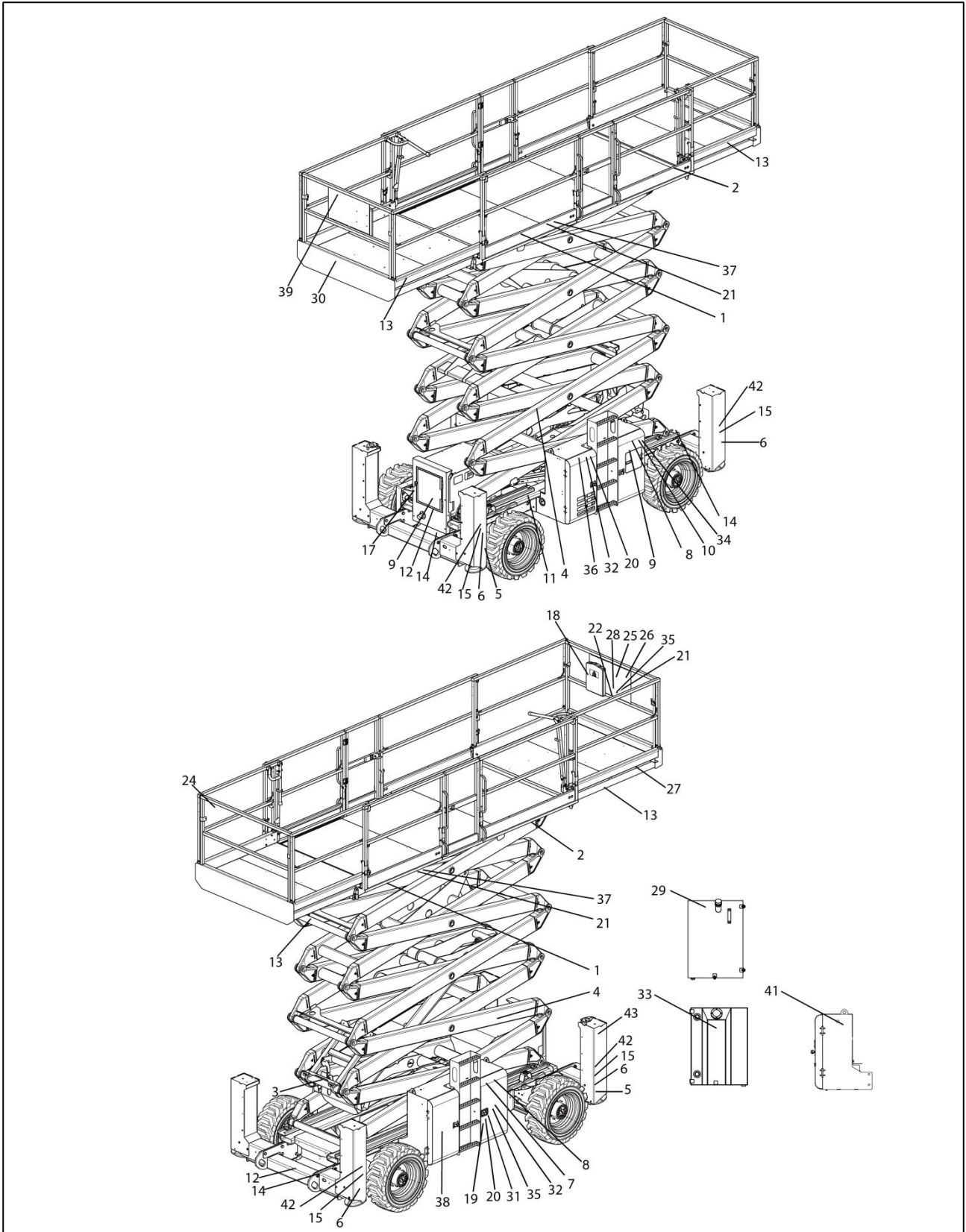





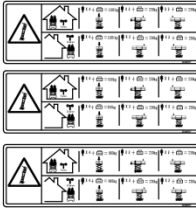

SR1023D/SR1323D/SR1623D Decals List

Code	Name	Code	Name
1	Company Logo	23	Annual inspection instruction
2	Model identification	24	Hazard mark of smashing and pressing
3	Forklift safety arm sign	25	Indicator mark of direction arrow
4	Stay away from machine sign	26	Prohibition mark
5	Direction indicator sign	27	Lanyard Anchorage Point
6	Wheel load capacity sign	28	Reduce platform warning sign
7	Electric shock hazard	29	Identification of hydraulic oil tank
8	Pressure hazard identification	30	IPAF
9	Mark of drive form	31	Prohibition of sparks sign
10	Emergency lowering mark	32	Attention in overhaul
11	Whole machine nameplate	33	Fuel tank mark
12	Identification of transport securing parts	34	CE
13	Warning line	35	Danger description
14	Hanger sign	36	Attention mark of skin infraction
15	Stay away from outrigger sign	37	Rated load mark
16	Maximum manual force sign	38	Company Logo
17	Hazard mark of tipping	39	Company Logo
18	Instructions sign	40	107 dB
19	Explosion burn warning sign	41	Power off sign
20	Warning	42	Load mark of outriggers
21	Danger-Outrigger Safety and Instructions	43	Decal-Ground check
22	Hazard mark of tipping		

SR1023D/SR1323D/SR1623D Decals

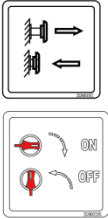
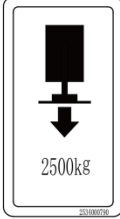
1-2534000335	2-2534001440/39/25	3-2534000032	4-2534000019	5-2534000102	6-2534001923
	<b>SR1023D</b> <b>SR1323D</b> <b>SR1623D</b>				
7-2534000009	8-2534000022	9-2534000056	10-2534000034	11-2534000773/2658	12-2534000182
		<b>4x4</b>			
13-2534000024	14-2831990027	15-2534000174	16-2534000179	17-2534000015	18-2534000119
19-2534000004	20-2534000145	21-2534000791	22-2534000172	23-2534000789	24-2534000173
	<b>WARNING</b> THIS MACHINE MUST NOT BE USED UNTIL IT IS INSPECTED AND OPERATING PROPERLY. 1. Do not operate, repair and maintenance on the platform unless you are trained and qualified. 2. Pay close attention to operation, repair and maintenance can result in injury and death! 3. Do not perform operation, repair and maintenance procedures unless you read, understand the manual completely! 4. To strictly follow the rated loading capacity, any consequences due to overloading or unauthorized modification shall be responsible by the users. 5. The operator procedures and precautions referred to herein are only applicable to the qualified operators of the machine. Be always assured that any operation out of the specification but not prohibited will not hurt anyone.	<b>DANGER</b> Failure to read, understand and obey the safety rules and operating instructions in the operator's manual will result in death or serious injury. <b>Tipover Hazards</b> Do not use platform unless machine is on a level, ground, surface that is firm, level, and free of any holes, ruts, or other possible hazards. Do not use while platform is lowered unless the forklift is lowered. Do not use while platform is lowered unless the forklift is lowered.			
25-2534000033	26-2534000229	27-2534000017	28-2534000013	29-2534001995	30-2534000272
					<b>IPAF</b>
31-2534000047	32-2534000011	33-2534000177	34-2534000276	35-2534000785	36-2534000029
				<b>DANGER</b> This machine will not be used in India or within its territory. <b>Prohibited Actions</b> Do not use the platform unless it is on a level, firm, and free of any holes, ruts, or other possible hazards. Do not use while platform is lowered unless the forklift is lowered. <b>Tipover Hazards</b> Do not use platform unless machine is on a level, ground, surface that is firm, level, and free of any holes, ruts, or other possible hazards. Do not use while platform is lowered unless the forklift is lowered. <b>Collision Hazards</b> Do not use the platform unless it is on a level, firm, and free of any holes, ruts, or other possible hazards. Do not use while platform is lowered unless the forklift is lowered. <b>Explosion and Fire Hazards</b> Do not use the platform unless it is on a level, firm, and free of any holes, ruts, or other possible hazards. Do not use while platform is lowered unless the forklift is lowered.	

37-2534000347/882/1877	38-2534000220	39-2534000221	40-2534000786	41-2534001921/2181	42-2534000790
					
43-2534003526					
					

## **Chapter 4 Specifications**



**Specifications**

**Parameters of SR0818D (S081800WNK5CH2000) Whole Machine**

**Performance Parameters of Whole Machine**

Item	Parameters	Item	Parameters
Rated load (kg)	680	Ascending speed (s)	35±4
Load of extension platform (kg)	140	Descending speed (s)	30±4
Weight of whole machine (Without outrigger/ With outrigger) (kg)	3700/4170	Theoretical climbing ability (mm)( Without outrigger/ With outrigger)	40%/35%
Maximum number of workers(In door)	4	Maximum allowable angle of operation (front and rear)	3°
Maximum number of workers(Outdoor)	4	Maximum allowable angle of operation (left and right)	2°
Maximum working height (m)	9.7	Maximum Leveling angle-Outrigger (Front and rear)	5.7° /5.5°
Maximum platform height (m)	7.7	Maximum Leveling angle-Outrigger (Left and right)	12°
Minimum turning radius (m)	4.75	Maximum wind speed (m/s)	12.5
Running speed of machine (Stowed) (km/h)	5.5±0.5	Running speed of machine (Platform raised) (km/h)	0.5±0.2
Running height (m)	7.7		

**Main Dimensions**

Item	Parameters	Item	Parameters
Length of whole machine ( Without outrigger/ With outrigger) (mm)	3110/3760	Extending size of platform(mm)	1520
Width of whole machine (mm)	1790	Wheel base (front/rear) (mm)	2290
Height of whole machine - unfolded guard railing (mm)	2580	Thread (mm)	1507
Height of whole machine - folded guard railing (mm)	1890	Ground clearance (mm)	230
Dimension of main platform (length × width) (mm)	2790×1600	Tire specification (diameter × width)(mm)	663×283

**Engine System**

Item	Parameters/Contents	Item	Parameters/Contents
Model	Kubota D1105-EF02	Rated speed (r/min)	3000
Rated power (KW)	18.2	Maximum torque (N.m)/speed (r/min)	71.5/2200
Displacement (ml)	1123	Emission standard	EU stage V

**Drive system**

Item	Specification/Content
Driving reducer	Output torque (N*m) 3390

**Hydraulic System**

Item		Specification/Content	
Driving system	Model	Open system	
	Pump displacement (ml/r)	16	
	Max working Pressure (Mpa)	21	
	Motor displacement (ml/r) (Front/Rear)	375/25	
Functional system	Model		Open system
	Pump displacement (ml/r)		16
	Lifting system	Max working Pressure (Mpa)	20
	Steering system	Max working Pressure (Mpa)	21

**Electrical System**

Item		Specification/Content
Battery	Output voltage (V)	12
	Capacity (AH)	80(20 hours)
Control system	Voltage (V)	12

**Fueling Capacity**



**Note: When hydraulic oil and diesel are filled, it is necessary to use the corresponding hydraulic oil and diesel according to operating environment and temperature, and refer to the following contents:**

Item	Condition	Type	Capacity	Remarks
Hydraulic oil(L)	-25°C < Minimum Ambient temperature	L-HV 32 low temperature hydraulic oil	50	Recommended Chevron
	-40°C < Minimum Ambient temperature ≤ -25°C	L-HS 32ultralow temperature hydraulic oil		
	Minimum Ambient temperature ≤ -40°C	10# aviation hydraulic oil		
Driving Reducer oil (L)	30° C < The lowest temperature	85W/140	0.68 × 2	API GL-5
	-10° C < The lowest temperature < 30° C	85W/90		
	-30° C < The lowest temperature < -10° C	80W/90		
	The lowest temperature < -30° C	75W		
Engine oil(L)	Working temperature: -20°C ~ 40°C	15W-40	3.5	API CH-4



	Working temperature:-25℃~30℃	10W-30		
	Working temperature:-30℃~30℃	5W-30		
	Working temperature:-35℃~20℃	0W-20		
Diesel (L)	Ambient temperature≥4℃	0 #Diesel	53	
	Ambient temperature≥-5℃	-10 #Diesel		
	Ambient temperature≥-14℃	-20 Diesel		
	Ambient temperature≥-29℃	-35 Diesel		
Antifreeze (L)	/	/	4	

**Specifications**

**Parameters of SR0818D (S081800Wnk5CH2005) Whole Machine**

**Performance Parameters of Whole Machine**

Item	Parameters	Item	Parameters
Rated load (kg)	680	Ascending speed (s)	35±4
Load of extension platform (kg)	140	Descending speed (s)	30±4
Weight of whole machine (Without outrigger/ With outrigger) (kg)	3700/4170	Theoretical climbing ability (mm)( Without outrigger/ With outrigger)	40%/35%
Maximum number of workers(In door)	4	Maximum allowable angle of operation (front and rear)	3°
Maximum number of workers(Outdoor)	4	Maximum allowable angle of operation (left and right)	2°
Maximum working height (m)	9.7	Maximum Leveling angle-Outrigger (Front and rear)	5.7° /5.5°
Maximum platform height (m)	7.7	Maximum Leveling angle-Outrigger (Left and right)	12°
Minimum turning radius (m)	4.75	Maximum wind speed (m/s)	12.5
Running speed of machine (Stowed) (km/h)	5.5±0.5	Running speed of machine (Platform raised) (km/h)	0.5±0.2
Running height (m)	7.7		

**Main Dimensions**

Item	Parameters	Item	Parameters
Length of whole machine ( Without outrigger/ With outrigger) (mm)	3110/3760	Extending size of platform(mm)	1520
Width of whole machine (mm)	1790	Wheel base (front/rear) (mm)	2290
Height of whole machine - unfolded guard railing (mm)	2580	Thread (mm)	1507
Height of whole machine - folded guard railing (mm)	1920	Ground clearance (mm)	230
Dimension of main platform (length × width) (mm)	2790×1600	Tire specification (diameter × width)(mm)	663×283

**Engine System**

Item	Parameters/Contents	Item	Parameters/Contents
Model	Kubota D1105-EF06e	Rated speed (r/min)	2500
Rated power (KW)	15.7	Maximum torque (N.m)	71.3
Displacement (ml)	1123	Emission standard	EU stage V

**Drive system**

Item	Specification/Content
Driving reducer	Output torque (N*m) 3390

**Hydraulic System**

Item		Specification/Content	
Driving system	Model	Open system	
	Pump displacement (ml/r)	16	
	Max working Pressure (Mpa)	21	
	Motor displacement (ml/r) (Front/Rear)	375/25	
Functional system	Model		Open system
	Pump displacement (ml/r)		16
	Lifting system	Max working Pressure (Mpa)	20
	Steering system	Max working Pressure (Mpa)	21

**Electrical System**

Item		Specification/Content
Battery	Output voltage (V)	12
	Capacity (AH)	80(20 hours)
Control system	Voltage (V)	12

**Fueling Capacity**



**Note: When hydraulic oil and diesel are filled, it is necessary to use the corresponding hydraulic oil and diesel according to operating environment and temperature, and refer to the following contents:**

Item	Condition	Type	Capacity	Remarks
Hydraulic oil(L)	-25°C < Minimum Ambient temperature	L-HV 32 low temperature hydraulic oil	50	Recommended Chevron
	-40°C < Minimum Ambient temperature ≤ -25°C	L-HS 32ultralow temperature hydraulic oil		
	Minimum Ambient temperature ≤ -40°C	10# aviation hydraulic oil		
Driving Reducer oil (L)	30° C < The lowest temperature	85W/140	0.68 × 2	API GL-5
	-10° C < The lowest temperature < 30° C	85W/90		
	-30° C < The lowest temperature < -10° C	80W/90		
	The lowest temperature < -30° C	75W		
Engine oil(L)	Working temperature: -20°C ~ 40°C	15W-40	3.5	API CH-4

	Working temperature:-25℃~30℃	10W-30		
	Working temperature:-30℃~30℃	5W-30		
	Working temperature:-35℃~20℃	0W-20		
Diesel (L)	Ambient temperature≥4℃	0 #Diesel	53	
	Ambient temperature≥-5℃	-10 #Diesel		
	Ambient temperature≥-14℃	-20 Diesel		
	Ambient temperature≥-29℃	-35 Diesel		
Antifreeze (L)	/	/	4	

**Specifications**

**Parameters of SR1018D (S10181NKCH20) Whole Machine**

**Performance Parameters of Whole Machine**

Item	Parameters	Item	Parameters
Rated load (kg)	454	Ascending speed (s)	39±4
Load of extension platform (kg)	140	Descending speed (s)	46±4
Weight of whole machine (kg)	4330	Theoretical climbing ability (mm)	35%
Maximum number of workers(In door)	4	Maximum allowable angle of operation (front and rear)	3°
Maximum number of workers(Outdoor)	2	Maximum allowable angle of operation (left and right)	2°
Maximum working height (m)	11.7	Maximum Leveling angle-Outrigger (Front and rear)	5.7° /5.5°
Maximum platform height (m)	9.7	Maximum Leveling angle-Outrigger (Left and right)	12°
Minimum turning radius (m)	4.75	Maximum wind speed (m/s)	12.5
Running speed of machine (Stowed) (km/h)	5.5±0.5	Running speed of machine (Platform raised) (km/h)	0.5±0.2
Running height (m)	9.7		

**Main Dimensions**

Item	Parameters	Item	Parameters
Length of whole machine (mm)	3760	Extending size of platform(mm)	1520
Width of whole machine (mm)	1790	Wheel base (front/rear) (mm)	2290
Height of whole machine - unfolded guard railing (mm)	2550	Thread (mm)	1507
Height of whole machine - folded guard railing (mm)	1890	Ground clearance (mm)	230
Dimension of main platform (length × width) (mm)	2790×1600	Tire specification (diameter × width)(mm)	663×283

**Engine System**

Item	Parameters/Contents	Item	Parameters/Contents
Model	Kubota D1105-EF02	Rated speed (r/min)	3000
Rated power (KW)	18.2	Maximum torque (N.m)/speed (r/min)	71.5/2200
Displacement (ml)	1123	Emission standard	EU stage V

**Drive system**

Item	Specification/Content
Driving reducer	Output torque (N*m) 3390

**Hydraulic System**

Item	Specification/Content
Driving system	Model Open system

	Pump displacement (ml/r)	16	
	Max working Pressure (Mpa)	21	
	Motor displacement (ml/r) (Front/Rear)	375/25	
Functional system	Model		Open system
	Pump displacement (ml/r)		16
	Lifting system	Max working Pressure (Mpa)	20
	Steering system	Max working Pressure (Mpa)	21

**Electrical System**

Item	Specification/Content	
Battery	Output voltage (V)	12
	Capacity (AH)	80(20 hours)
Control system	Voltage (V)	12

**Fueling Capacity**



**Note:** When hydraulic oil and diesel are filled, it is necessary to use the corresponding hydraulic oil and diesel according to operating environment and temperature, and refer to the following contents:

Item	Condition	Type	Capacity	Remarks
Hydraulic oil(L)	-25°C < Minimum Ambient temperature	L-HV 32 low temperature hydraulic oil	50	Recommended Chevron
	-40°C < Minimum Ambient temperature ≤ -25°C	L-HS 32ultralow temperature hydraulic oil		
	Minimum Ambient temperature ≤ -40°C	10# aviation hydraulic oil		
Driving Reducer oil (L)	30° C < The lowest temperature	85W/140	0.68 × 2	API GL-5
	-10° C < The lowest temperature < 30° C	85W/90		
	-30° C < The lowest temperature < -10° C	80W/90		
	The lowest temperature < -30° C	75W		
Engine oil(L)	Working temperature: -20°C ~ 40°C	15W-40	3.5	API CH-4
	Working temperature: -25°C ~ 30°C	10W-30		
	Working temperature: -30°C ~ 30°C	5W-30		
	Working temperature: -35°C ~ 20°C	0W-20		

Diesel (L)	Ambient temperature $\geq$ 4 $^{\circ}$ C	0 #Diesel	53	
	Ambient temperature $\geq$ -5 $^{\circ}$ C	-10 #Diesel		
	Ambient temperature $\geq$ -14 $^{\circ}$ C	-20 Diesel		
	Ambient temperature $\geq$ -29 $^{\circ}$ C	-35 Diesel		
Antifreeze (L)	/	/	4	

**Specifications**

**Parameters of SR1018D (S101800Wnk5CH2000) Whole Machine**

**Performance Parameters of Whole Machine**

Item	Parameters	Item	Parameters
Rated load (kg)	454	Ascending speed (s)	39±4
Load of extension platform (kg)	140	Descending speed (s)	46±4
Weight of whole machine (kg)	4330	Theoretical climbing ability (mm)	35%
Maximum number of workers(In door)	4	Maximum allowable angle of operation (front and rear)	3°
Maximum number of workers(Outdoor)	2	Maximum allowable angle of operation (left and right)	2°
Maximum working height (m)	11.7	Maximum Leveling angle-Outrigger (Front and rear)	5.7° /5.5°
Maximum platform height (m)	9.7	Maximum Leveling angle-Outrigger (Left and right)	12°
Minimum turning radius (m)	4.75	Maximum wind speed (m/s)	12.5
Running speed of machine (Stowed) (km/h)	5.5±0.5	Running speed of machine (Platform raised) (km/h)	0.5±0.2
Running height (m)	9.7		

**Main Dimensions**

Item	Parameters	Item	Parameters
Length of whole machine (mm)	3760	Extending size of platform(mm)	1520
Width of whole machine (mm)	1790	Wheel base (front/rear) (mm)	2290
Height of whole machine - unfolded guard railing (mm)	2550	Thread (mm)	1507
Height of whole machine - folded guard railing (mm)	1890	Ground clearance (mm)	230
Dimension of main platform (length × width) (mm)	2790×1600	Tire specification (diameter × width)(mm)	663×283

**Engine System**

Item	Parameters/Contents	Item	Parameters/Contents
Model	Kubota D1105-EF06e	Rated speed (r/min)	2500
Rated power (KW)	15.7	Maximum torque (N.m)	71.3
Displacement (ml)	1123	Emission standard	EU stage V

**Drive system**

Item	Specification/Content
Driving reducer	Output torque (N*m) 3390



**Hydraulic System**

Item		Specification/Content	
Driving system	Model	Open system	
	Pump displacement (ml/r)	16	
	Max working Pressure (Mpa)	21	
	Motor displacement (ml/r) (Front/Rear)	375/25	
Functional system	Model		Open system
	Pump displacement (ml/r)		16
	Lifting system	Max working Pressure (Mpa)	20
	Steering system	Max working Pressure (Mpa)	21

**Electrical System**

Item		Specification/Content
Battery	Output voltage (V)	12
	Capacity (AH)	80(20 hours)
Control system	Voltage (V)	12

**Fueling Capacity**



**Note: When hydraulic oil and diesel are filled, it is necessary to use the corresponding hydraulic oil and diesel according to operating environment and temperature, and refer to the following contents:**

Item	Condition	Type	Capacity	Remarks
Hydraulic oil(L)	-25°C < Minimum Ambient temperature	L-HV 32 low temperature hydraulic oil	50	Recommended Chevron
	-40°C < Minimum Ambient temperature ≤ -25°C	L-HS 32ultralow temperature hydraulic oil		
	Minimum Ambient temperature ≤ -40°C	10# aviation hydraulic oil		
Driving Reducer oil (L)	30° C < The lowest temperature	85W/140	0.68 × 2	API GL-5
	-10° C < The lowest temperature < 30° C	85W/90		
	-30° C < The lowest temperature < -10° C	80W/90		
	The lowest temperature < -30° C	75W		
Engine oil(L)	Working temperature: -20°C ~ 40°C	15W-40	3.5	API CH-4

	Working temperature:-25℃~30℃	10W-30		
	Working temperature:-30℃~30℃	5W-30		
	Working temperature:-35℃~20℃	0W-20		
Diesel (L)	Ambient temperature≥4℃	0 #Diesel	53	
	Ambient temperature≥-5℃	-10 #Diesel		
	Ambient temperature≥-14℃	-20 Diesel		
	Ambient temperature≥-29℃	-35 Diesel		
Antifreeze (L)	/	/	4	

**Specifications**

**Parameters of SR1218D (S12181NKCH20) Whole Machine**

**Performance Parameters of Whole Machine**

Item	Parameters	Item	Parameters
Rated load (kg)	365	Ascending speed (s)	61 ± 4
Load of extension platform (kg)	140	Descending speed (s)	55 ± 4
Weight of whole machine (kg)	5080	Theoretical climbing ability (mm)	35%
Maximum number of workers(In door)	3	Maximum allowable angle of operation (front and rear)	3°
Maximum number of workers(Outdoor)	2	Maximum allowable angle of operation (left and right)	2°
Maximum working height (m)	13.9	Maximum Leveling angle of Outrigger (Front and rear)	5.7° /5.5°
Maximum platform height (m)	11.9	Maximum Leveling angle of Outrigger (Left and right)	12°
Minimum turning radius (m)	4.75	Maximum wind speed (m/s)	12.5
Running speed of machine (Stowed) (km/h)	5.5 ± 0.5	Running speed of machine (Platform raised) (km/h)	0.5 ± 0.2
Running height (m)	11.9		

**Main Dimensions**

Item	Parameters	Item	Parameters
Length of whole machine (mm)	3760	Extending size of platform(mm)	1520
Width of whole machine (mm)	1790	Wheel base (front/rear) (mm)	2290
Height of whole machine - unfolded guard railing (mm)	2700	Thread (mm)	1507
Height of whole machine - folded guard railing (mm)	2040	Ground clearance (mm)	230
Dimension of main platform (length × width) (mm)	2790 × 1600	Tire specification (diameter × width)(mm)	663 × 283

**Engine System**

Item	Parameters/Contents	Item	Parameters/Contents
Model	Kubota D1105-EF02	Rated speed (r/min)	3000
Rated power (KW)	18.2	Maximum torque (N.m)/speed (r/min)	71.5/2200
Displacement (ml)	1123	Emission standard	EU stage V

**Drive system**

Item	Specification/Content
Driving reducer	Output torque (N*m) 3390

**Hydraulic System**

Item		Specification/Content	
Driving system	Model	Open system	
	Pump displacement (ml/r)	16	
	Max working Pressure (Mpa)	21	
	Motor displacement (ml/r) (Front/Rear)	375/25	
Functional system	Model		Open system
	Pump displacement (ml/r)		16
	Lifting system	Max working Pressure (Mpa)	20
	Steering system	Max working Pressure (Mpa)	21

**Electrical System**

Item		Specification/Content
Battery	Output voltage (V)	12
	Capacity (AH)	80(20 hours)
Control system	Voltage (V)	12

**Fueling Capacity**



**Note: When hydraulic oil and diesel are filled, it is necessary to use the corresponding hydraulic oil and diesel according to operating environment and temperature, and refer to the following contents:**

Item	Condition	Type	Capacity	Remarks
Hydraulic oil(L)	-25°C < Minimum Ambient temperature	L-HV 32 low temperature hydraulic oil	50	Recommended Chevron
	-40°C < Minimum Ambient temperature ≤ -25°C	L-HS 32ultralow temperature hydraulic oil		
	Minimum Ambient temperature ≤ -40°C	10# aviation hydraulic oil		
Driving Reducer oil (L)	30° C < The lowest temperature	85W/140	0.68 × 2	API GL-5
	-10° C < The lowest temperature < 30° C	85W/90		
	-30° C < The lowest temperature < -10° C	80W/90		
	The lowest temperature < -30° C	75W		
Engine oil(L)	Working temperature: -20°C ~ 40°C	15W-40	3.5	API CH-4

	Working temperature:-25℃~30℃	10W-30		
	Working temperature:-30℃~30℃	5W-30		
	Working temperature:-35℃~20℃	0W-20		
Diesel (L)	Ambient temperature≥4℃	0 #Diesel	53	
	Ambient temperature≥-5℃	-10 #Diesel		
	Ambient temperature≥-14℃	-20 Diesel		
	Ambient temperature≥-29℃	-35 Diesel		
Antifreeze (L)	/	/	4	

**Specifications**

**Parameters of SR1218D (S121800Wnk5CH2000) Whole Machine**

**Performance Parameters of Whole Machine**

Item	Parameters	Item	Parameters
Rated load (kg)	365	Ascending speed (s)	61 ± 4
Load of extension platform (kg)	140	Descending speed (s)	55 ± 4
Weight of whole machine (kg)	5080	Theoretical climbing ability (mm)	35%
Maximum number of workers(In door)	3	Maximum allowable angle of operation (front and rear)	3°
Maximum number of workers(Outdoor)	2	Maximum allowable angle of operation (left and right)	2°
Maximum working height (m)	13.9	Maximum Leveling angle of Outrigger (Front and rear)	5.7° /5.5°
Maximum platform height (m)	11.9	Maximum Leveling angle of Outrigger (Left and right)	12°
Minimum turning radius (m)	4.75	Maximum wind speed (m/s)	12.5
Running speed of machine (Stowed) (km/h)	5.5 ± 0.5	Running speed of machine (Platform raised) (km/h)	0.5 ± 0.2
Running height (m)	11.9		

**Main Dimensions**

Item	Parameters	Item	Parameters
Length of whole machine (mm)	3760	Extending size of platform(mm)	1520
Width of whole machine (mm)	1790	Wheel base (front/rear) (mm)	2290
Height of whole machine - unfolded guard railing (mm)	2700	Thread (mm)	1507
Height of whole machine - folded guard railing (mm)	2040	Ground clearance (mm)	230
Dimension of main platform (length × width) (mm)	2790 × 1600	Tire specification (diameter × width)(mm)	663 × 283

**Engine System**

Item	Parameters/Contents	Item	Parameters/Contents
Model	Kubota D1105-EF06e	Rated speed (r/min)	2500
Rated power (KW)	15.7	Maximum torque (N.m)	71.3
Displacement (ml)	1123	Emission standard	EU stage V

**Drive system**

Item	Specification/Content
Driving reducer	Output torque (N*m) 3390

**Hydraulic System**

Item	Specification/Content
Driving system	Model Open system

	Pump displacement (ml/r)	16	
	Max working Pressure (Mpa)	21	
	Motor displacement (ml/r) (Front/Rear)	375/25	
Functional system	Model		Open system
	Pump displacement (ml/r)		16
	Lifting system	Max working Pressure (Mpa)	20
	Steering system	Max working Pressure (Mpa)	21

**Electrical System**

Item	Specification/Content	
Battery	Output voltage (V)	12
	Capacity (AH)	80(20 hours)
Control system	Voltage (V)	12

**Fueling Capacity**



**Note:** When hydraulic oil and diesel are filled, it is necessary to use the corresponding hydraulic oil and diesel according to operating environment and temperature, and refer to the following contents:

Item	Condition	Type	Capacity	Remarks
Hydraulic oil(L)	-25°C < Minimum Ambient temperature	L-HV 32 low temperature hydraulic oil	50	Recommended Chevron
	-40°C < Minimum Ambient temperature ≤ -25°C	L-HS 32ultralow temperature hydraulic oil		
	Minimum Ambient temperature ≤ -40°C	10# aviation hydraulic oil		
Driving Reducer oil (L)	30° C < The lowest temperature	85W/140	0.68 × 2	API GL-5
	-10° C < The lowest temperature < 30° C	85W/90		
	-30° C < The lowest temperature < -10° C	80W/90		
	The lowest temperature < -30° C	75W		
Engine oil(L)	Working temperature: -20°C ~ 40°C	15W-40	3.5	API CH-4
	Working temperature: -25°C ~ 30°C	10W-30		
	Working temperature: -30°C ~ 30°C	5W-30		
	Working temperature: -35°C ~ 20°C	0W-20		

Diesel (L)	Ambient temperature $\geq$ 4 $^{\circ}$ C	0 #Diesel	53	
	Ambient temperature $\geq$ -5 $^{\circ}$ C	-10 #Diesel		
	Ambient temperature $\geq$ -14 $^{\circ}$ C	-20 Diesel		
	Ambient temperature $\geq$ -29 $^{\circ}$ C	-35 Diesel		
Antifreeze (L)	/	/	4	



**Specifications**

**Parameters of SR1023D (S10231NDCH20) Whole Machine**

**Performance Parameters of Whole Machine**

Item	Parameters	Item	Parameters
Rated load (kg)	1100	Ascending speed (s)	45
Load of extension platform (kg)	230	Descending speed (s)	45
Weight of whole machine (kg)	6980	Theoretical climbing ability (mm)	40%
Maximum number of workers	7	Maximum allowable angle of operation (front and rear)	3°
Maximum working height (m)	12	Maximum allowable angle of operation (left and right)	2°
Maximum platform height (m)	10	Maximum leveling angle of outrigger (from front to rear)	7°
Minimum turning radius (outer wheel) (m)	5.33	Maximum leveling angle of outrigger (from left to right)	12°
Running speed of machine (folding state) (km/h)	6.1±0.2	Maximum wind speed (m/s)	12.5
Running speed of machine (rising state) (km/h)	1.1±0.1	Running height (m)	10

**Main Dimensions**

Item	Parameters	Item	Parameters
Length of whole machine (mm)	4900	Extending size of platform(mm)	1450/1140
Width of whole machine (mm)	2300	Wheel base (front/rear) (mm)	2850
Height of whole machine - unfolded guard railing (mm)	2740	Thread (mm)	1993
Height of whole machine - folded guard railing (mm)	2060	Ground clearance (mm)	230
Dimension of main platform (length x width) (mm)	4810x1830	Tire specification (diameter x width)	835x290

**Engine System**

Item	Parameters/Contents	Item	Parameters/Contents
Model	DEUTZ D2.9L4	Rated speed (r/min)	2,600
Rated power (KW)	36.4	Maximum torque (N.m)/speed (r/min)	147/1,600
Displacement (ml)	2900	Emission standard	EU stage V

**Drive system**

Item	Specification/Content
Driving reducer	Output torque (N*m) 7000

**Hydraulic System**

Item	Specification/Content
Driving system	Model Open system

	Pump displacement (ml/r)	49	
	Max working Pressure (Mpa)	28	
	Motor displacement (ml/r) (Front/Rear)	38/38	
Functional system	Model		Open system
	Pump displacement (ml/r)		16
	Lifting system	Max working Pressure (Mpa)	20
	Steering system	Max working Pressure (Mpa)	13.8

### Electrical System

Item	Specification/Content	
Battery	Output voltage (V)	12
	Capacity (AH)	120(20 hours)
Control system	Voltage (V)	12

### Fueling Capacity



**Note:** When hydraulic oil and diesel are filled, it is necessary to use the corresponding hydraulic oil and diesel according to operating environment and temperature, and refer to the following contents:

Item	Condition	Type	Capacity	Remarks
Hydraulic oil(L)	-25°C < Minimum Ambient temperature	L-HV 32 low temperature hydraulic oil	140	Recommended Chevron
	-40°C < Minimum Ambient temperature ≤ -25°C	L-HS 32ultralow temperature hydraulic oil		
	Minimum Ambient temperature ≤ -40°C	10# aviation hydraulic oil		
Driving Reducer oil (L)	30° C < The lowest temperature	85W/140	0.68 × 4	API GL-5
	-10° C < The lowest temperature < 30° C	85W/90		
	-30° C < The lowest temperature < -10° C	80W/90		
	The lowest temperature < -30° C	75W		
Engine oil(L)	Working temperature: -20°C ~ 40°C	15W-40	8	API CH-4
	Working temperature: -25°C ~ 30°C	10W-30		
	Working temperature: -30°C ~ 30°C	5W-30		
	Working temperature: -35°C ~ 20°C	0W-20		

Diesel (L)	Ambient temperature $\geq$ 4 $^{\circ}$ C	0 #Diesel	110	
	Ambient temperature $\geq$ -5 $^{\circ}$ C	-10 #Diesel		
	Ambient temperature $\geq$ -14 $^{\circ}$ C	-20 Diesel		
	Ambient temperature $\geq$ -29 $^{\circ}$ C	-35 Diesel		
Antifreeze (L)	/	/	8.5	

**Specifications**

**Parameters of SR1323D (S13231NDCH20) Whole Machine**

**Performance Parameters of Whole Machine**

Item	Parameters	Item	Parameters
Rated load (kg)	910	Ascending speed (s)	55
Load of extension platform (kg)	230	Descending speed (s)	55
Weight of whole machine (kg)	7460	Theoretical climbing ability (mm)	40%
Maximum number of workers	7	Maximum allowable angle of operation (front and rear)	3°
Maximum working height (m)	15	Maximum allowable angle of operation (left and right)	2°
Maximum platform height (m)	13	Maximum leveling angle of outrigger (from front to rear)	7°
Minimum turning radius (outer wheel) (m)	5.33	Maximum leveling angle of outrigger (from left to right)	12°
Running speed of machine (folding state) (km/h)	6.1±0.2	Maximum wind speed (m/s)	12.5
Running speed of machine (rising state) (km/h)	1.1±0.1	Running height (m)	8.5

**Main Dimensions**

Item	Parameters	Item	Parameters
Length of whole machine (mm)	4900	Extending size of platform(mm)	1450/1140
Width of whole machine (mm)	2300	Wheel base (front/rear) (mm)	2850
Height of whole machine - unfolded guard railing (mm)	2960	Thread (mm)	1993
Height of whole machine - folded guard railing (mm)	2280	Ground clearance (mm)	230
Dimension of main platform (length x width) (mm)	4810x1830	Tire specification (diameter xwidth)	835x290

**Engine System**

Item	Parameters/Contents	Item	Parameters/Contents
Model	DEUTZ D2.9L4	Rated speed (r/min)	2,600
Rated power (KW)	36.4	Maximum torque (N.m)/speed (r/min)	147/1,600
Displacement (ml)	2900	Emission standard	EU stage V

**Drive system**

Item	Specification/Content
Driving reducer	Output torque (N*m) 7000

**Hydraulic System**

Item	Specification/Content
Driving system	Model Open system

	Pump displacement (ml/r)	49	
	Max working Pressure (Mpa)	28	
	Motor displacement (ml/r) (Front/Rear)	38/38	
Functional system	Model		Open system
	Pump displacement (ml/r)		16
	Lifting system	Max working Pressure (Mpa)	20
	Steering system	Max working Pressure (Mpa)	13.8

### Electrical System

Item		Specification/Content
Battery	Output voltage (V)	12
	Capacity (AH)	120(20 hours)
Control system	Voltage (V)	12

### Fueling Capacity



**Note:** When hydraulic oil and diesel are filled, it is necessary to use the corresponding hydraulic oil and diesel according to operating environment and temperature, and refer to the following contents:

Item	Condition	Type	Capacity	Remarks
Hydraulic oil(L)	-25°C < Minimum Ambient temperature	L-HV 32 low temperature hydraulic oil	140	Recommended Chevron
	-40°C < Minimum Ambient temperature ≤ -25°C	L-HS 32ultralow temperature hydraulic oil		
	Minimum Ambient temperature ≤ -40°C	10# aviation hydraulic oil		
Driving Reducer oil (L)	30° C < The lowest temperature	85W/140	0.68 × 4	API GL-5
	-10° C < The lowest temperature < 30° C	85W/90		
	-30° C < The lowest temperature < -10° C	80W/90		
	The lowest temperature < -30° C	75W		
Engine oil(L)	Working temperature: -20°C ~ 40°C	15W-40	8	API CH-4
	Working temperature: -25°C ~ 30°C	10W-30		
	Working temperature: -30°C ~ 30°C	5W-30		
	Working temperature: -35°C ~ 20°C	0W-20		

Diesel (L)	Ambient temperature $\geq$ 4 $^{\circ}$ C	0 #Diesel	110	
	Ambient temperature $\geq$ -5 $^{\circ}$ C	-10 #Diesel		
	Ambient temperature $\geq$ -14 $^{\circ}$ C	-20 Diesel		
	Ambient temperature $\geq$ -29 $^{\circ}$ C	-35 Diesel		
Antifreeze (L)	/	/	8.5	

**Specifications**

**Parameters of SR1623D (S16231NDCH20) Whole Machine**

**Performance Parameters of Whole Machine**

Item	Parameters	Item	Parameters
Rated load (kg)	680	Ascending speed (s)	55
Load of extension platform (kg)	230	descending speed (s)	55
Weight of whole machine (kg)	8200	Theoretical climbing ability (mm)	40%
Maximum number of workers	4	Maximum leveling angle of outrigger (from left to right)	12°
Maximum working height (m)	17.9	Maximum leveling angle of outrigger (from front to rear)	7°
Maximum platform height (m)	15.9	Maximum allowable angle of operation (front and rear)	3°
Minimum turning radius (outer wheel) (m)	5.33	Maximum allowable angle of operation (left and right)	2°
Running speed of machine (folding state) (km/h)	6.1±0.2	Maximum wind speed (m/s)	12.5
Running speed of machine (rising state) (km/h)	1.1±0.1	Running height (m)	8.5

**Main Dimensions**

Item	Parameters	Item	Parameters
Length of whole machine (mm)	4900	Extending size of platform(mm)	1450/1140
Width of whole machine (mm)	2300	Wheel base (front/rear) (mm)	2850
Height of whole machine - unfolded guard railing (mm)	3180	Thread (mm)	1993
Height of whole machine - folded guard railing (mm)	2500	Ground clearance (mm)	210
Dimension of main platform (length x width) (mm)	4810x1830	Tire specification (diameter x width)	835x290

**Engine System**

Item	Parameters/Contents	Item	Parameters/Contents
Model	DEUTZ D2.9L4	Rated speed (r/min)	2,600
Rated power (KW)	36.4	Maximum torque (N.m)/speed (r/min)	147/1,600
Displacement (ml)	2900	Emission standard	EU stage V

**Drive system**

Item	Specification/Content
Driving reducer	Output torque (N*m) 7000

**Hydraulic System**

Item	Specification/Content
Driving system	Model Open system

	Pump displacement (ml/r)	49	
	Max working Pressure (Mpa)	28	
	Motor displacement (ml/r) (Front/Rear)	38/38	
Functional system	Model		Open system
	Pump displacement (ml/r)		16
	Lifting system	Max working Pressure (Mpa)	20
	Steering system	Max working Pressure (Mpa)	13.8

**Electrical System**

Item	Specification/Content	
Battery	Output voltage (V)	12
	Capacity (AH)	120(20 hours)
Control system	Voltage (V)	12

**Fueling Capacity**



**Note:** When hydraulic oil and diesel are filled, it is necessary to use the corresponding hydraulic oil and diesel according to operating environment and temperature, and refer to the following contents:

Item	Condition	Type	Capacity	Remarks
Hydraulic oil(L)	-25°C < Minimum Ambient temperature	L-HV 32 low temperature hydraulic oil	140	Recommended Chevron
	-40°C < Minimum Ambient temperature ≤ -25°C	L-HS 32ultralow temperature hydraulic oil		
	Minimum Ambient temperature ≤ -40°C	10# aviation hydraulic oil		
Driving Reducer oil (L)	30°C < The lowest temperature	85W/140	0.68 × 4	API GL-5
	-10°C < The lowest temperature < 30°C	85W/90		
	-30°C < The lowest temperature < -10°C	80W/90		
	The lowest temperature < -30°C	75W		
Engine oil(L)	Working temperature: -20°C ~ 40°C	15W-40	8	API CH-4
	Working temperature: -25°C ~ 30°C	10W-30		
	Working temperature: -30°C ~ 30°C	5W-30		
	Working temperature: -35°C ~ 20°C	0W-20		
Diesel (L)	Ambient temperature ≥ 4°C	0 #Diesel	110	



	Ambient temperature $\geq$ -5 $^{\circ}$ C	-10 #Diesel		
	Ambient temperature $\geq$ -14 $^{\circ}$ C	-20 Diesel		
	Ambient temperature $\geq$ -29 $^{\circ}$ C	-35 Diesel		
Antifreeze (L)	/	/	8.5	

**Specifications**

**Parameters of SR1023D (S102300WNK5CH2000) Whole Machine**

**Performance Parameters of Whole Machine**

Item	Parameters	Item	Parameters
Rated load (kg)	1100	Ascending speed (s)	45
Load of extension platform (kg)	230	Descending speed (s)	45
Weight of whole machine (kg)	6980	Theoretical climbing ability (mm)	40%
Maximum number of workers	7	Maximum allowable angle of operation (front and rear)	3°
Maximum working height (m)	12	Maximum allowable angle of operation (left and right)	2°
Maximum platform height (m)	10	Maximum leveling angle of outrigger (from front to rear)	7°
Minimum turning radius (outer wheel) (m)	5.33	Maximum leveling angle of outrigger (from left to right)	12°
Running speed of machine (folding state) (km/h)	6.1±0.2	Maximum wind speed (m/s)	12.5
Running speed of machine (rising state) (km/h)	1.1±0.1	Running height (m)	10

**Main Dimensions**

Item	Parameters	Item	Parameters
Length of whole machine (mm)	4900	Extending size of platform(mm)	1450/1140
Width of whole machine (mm)	2300	Wheel base (front/rear) (mm)	2850
Height of whole machine - unfolded guard railing (mm)	2740	Thread (mm)	1993
Height of whole machine - folded guard railing (mm)	2060	Ground clearance (mm)	230
Dimension of main platform (length x width) (mm)	4810x1830	Tire specification (diameter x width)	835x290

**Engine System**

Item	Parameters/Contents	Item	Parameters/Contents
Model	V2403-CR-E5	Rated speed (r/min)	2600
Rated power (KW)	36	Maximum torque (N.m)	159.8
Displacement (ml)	2434	Emission standard	EU stage V

**Drive system**

Item	Specification/Content
Driving reducer	Output torque (N*m) 7000

**Hydraulic System**

Item	Specification/Content
Driving system	Model Closed system

	Pump displacement (ml/r)	46	
	Max working Pressure (Mpa)	28	
	Motor displacement (ml/r) (Front/Rear)	38/38	
Functional system	Model		Open system
	Pump displacement (ml/r)		16
	Lifting system	Max working Pressure (Mpa)	20
	Steering system	Max working Pressure (Mpa)	13.8

**Electrical System**

Item	Specification/Content	
Battery	Output voltage (V)	12
	Capacity (AH)	120(20 hours)
Control system	Voltage (V)	12

**Fueling Capacity**



**Note:** When hydraulic oil and diesel are filled, it is necessary to use the corresponding hydraulic oil and diesel according to operating environment and temperature, and refer to the following contents:

Item	Condition	Type	Capacity	Remarks
Hydraulic oil(L)	-25°C < Minimum Ambient temperature	L-HV 32 low temperature hydraulic oil	140	Recommended Chevron
	-40°C < Minimum Ambient temperature ≤ -25°C	L-HS 32ultralow temperature hydraulic oil		
	Minimum Ambient temperature ≤ -40°C	10# aviation hydraulic oil		
Driving Reducer oil (L)	30° C < The lowest temperature	85W/140	0.68 × 4	API GL-5
	-10° C < The lowest temperature < 30° C	85W/90		
	-30° C < The lowest temperature < -10° C	80W/90		
	The lowest temperature < -30° C	75W		
Engine oil(L)	Working temperature: -20°C ~ 40°C	15W-40	8.5	API CJ-4
	Working temperature: -25°C ~ 30°C	10W-30		
	Working temperature: -30°C ~ 30°C	5W-30		
	Working temperature: -35°C ~ 20°C	0W-20		

Diesel (L)	Ambient temperature $\geq 4^{\circ}\text{C}$	0 #Diesel	100	ULSD
	Ambient temperature $\geq -5^{\circ}\text{C}$	-10 #Diesel		
	Ambient temperature $\geq -14^{\circ}\text{C}$	-20 Diesel		
	Ambient temperature $\geq -29^{\circ}\text{C}$	-35 Diesel		
Antifreeze (L)	/	50% LLC/50% clean soft water	8.5	

**Specifications**

**Parameters of SR1323D (S132300Wnk5CH2000) Whole Machine**

**Performance Parameters of Whole Machine**

Item	Parameters	Item	Parameters
Rated load (kg)	910	Ascending speed (s)	55
Load of extension platform (kg)	230	Descending speed (s)	55
Weight of whole machine (kg)	7460	Theoretical climbing ability (mm)	40%
Maximum number of workers	7	Maximum allowable angle of operation (front and rear)	3°
Maximum working height (m)	15	Maximum allowable angle of operation (left and right)	2°
Maximum platform height (m)	13	Maximum leveling angle of outrigger (from front to rear)	7°
Minimum turning radius (outer wheel) (m)	5.33	Maximum leveling angle of outrigger (from left to right)	12°
Running speed of machine (folding state) (km/h)	6.1±0.2	Maximum wind speed (m/s)	12.5
Running speed of machine (rising state) (km/h)	1.1±0.1	Running height (m)	8.5

**Main Dimensions**

Item	Parameters	Item	Parameters
Length of whole machine (mm)	4900	Extending size of platform(mm)	1450/1140
Width of whole machine (mm)	2300	Wheel base (front/rear) (mm)	2850
Height of whole machine - unfolded guard railing (mm)	2960	Thread (mm)	1993
Height of whole machine - folded guard railing (mm)	2280	Ground clearance (mm)	230
Dimension of main platform (length x width) (mm)	4810x1830	Tire specification (diameter xwidth)	835x290

**Engine System**

Item	Parameters/Contents	Item	Parameters/Contents
Model	V2403-CR-E5	Rated speed (r/min)	2600
Rated power (KW)	36	Maximum torque (N.m)	159.8
Displacement (ml)	2434	Emission standard	EU stage V

**Drive system**

Item	Specification/Content
Driving reducer	Output torque (N*m) 7000

**Hydraulic System**

Item	Specification/Content
Driving system	Model Closed system

	Pump displacement (ml/r)	46	
	Max working Pressure (Mpa)	28	
	Motor displacement (ml/r) (Front/Rear)	38/38	
Functional system	Model		Open system
	Pump displacement (ml/r)		16
	Lifting system	Max working Pressure (Mpa)	20
	Steering system	Max working Pressure (Mpa)	13.8

### Electrical System

Item	Specification/Content	
Battery	Output voltage (V)	12
	Capacity (AH)	120(20 hours)
Control system	Voltage (V)	12

### Fueling Capacity



**Note:** When hydraulic oil and diesel are filled, it is necessary to use the corresponding hydraulic oil and diesel according to operating environment and temperature, and refer to the following contents:

Item	Condition	Type	Capacity	Remarks
Hydraulic oil(L)	-25°C < Minimum Ambient temperature	L-HV 32 low temperature hydraulic oil	140	Recommended Chevron
	-40°C < Minimum Ambient temperature ≤ -25°C	L-HS 32ultralow temperature hydraulic oil		
	Minimum Ambient temperature ≤ -40°C	10# aviation hydraulic oil		
Driving Reducer oil (L)	30° C < The lowest temperature	85W/140	0.68 × 4	API GL-5
	-10° C < The lowest temperature < 30° C	85W/90		
	-30° C < The lowest temperature < -10° C	80W/90		
	The lowest temperature < -30° C	75W		
Engine oil(L)	Working temperature: -20°C ~ 40°C	15W-40	8.5	API CJ-4
	Working temperature: -25°C ~ 30°C	10W-30		
	Working temperature: -30°C ~ 30°C	5W-30		
	Working temperature: -35°C ~ 20°C	0W-20		

Diesel (L)	Ambient temperature $\geq 4^{\circ}\text{C}$	0 #Diesel	100	ULSD
	Ambient temperature $\geq -5^{\circ}\text{C}$	-10 #Diesel		
	Ambient temperature $\geq -14^{\circ}\text{C}$	-20 Diesel		
	Ambient temperature $\geq -29^{\circ}\text{C}$	-35 Diesel		
Antifreeze (L)	/	50% LLC/50% clean soft water	8.5	

**Specifications**

**Parameters of SR1623D (S162300WNK5CH2000) Whole Machine**

**Performance Parameters of Whole Machine**

Item	Parameters	Item	Parameters
Rated load (kg)	680	Ascending speed (s)	55
Load of extension platform (kg)	230	descending speed (s)	55
Weight of whole machine (kg)	8200	Theoretical climbing ability (mm)	40%
Maximum number of workers	4	Maximum leveling angle of outrigger (from left to right)	12°
Maximum working height (m)	17.9	Maximum leveling angle of outrigger (from front to rear)	7°
Maximum platform height (m)	15.9	Maximum allowable angle of operation (front and rear)	3°
Minimum turning radius (outer wheel) (m)	5.33	Maximum allowable angle of operation (left and right)	2°
Running speed of machine (folding state) (km/h)	6.1±0.2	Maximum wind speed (m/s)	12.5
Running speed of machine (rising state) (km/h)	1.1±0.1	Running height (m)	8.5

**Main Dimensions**

Item	Parameters	Item	Parameters
Length of whole machine (mm)	4900	Extending size of platform(mm)	1450/1140
Width of whole machine (mm)	2300	Wheel base (front/rear) (mm)	2850
Height of whole machine - unfolded guard railing (mm)	3180	Thread (mm)	1993
Height of whole machine - folded guard railing (mm)	2500	Ground clearance (mm)	230
Dimension of main platform (length x width) (mm)	4810x1830	Tire specification (diameter x width)	835x290

**Engine System**

Item	Parameters/Contents	Item	Parameters/Contents
Model	V2403-CR-E5	Rated speed (r/min)	2600
Rated power (KW)	36	Maximum torque (N.m)	159.8
Displacement (ml)	2434	Emission standard	EU stage V

**Drive system**

Item	Specification/Content
Driving reducer	Output torque (N*m) 7000

**Hydraulic System**

Item	Specification/Content
Driving system	Model Closed system



	Pump displacement (ml/r)	46	
	Max working Pressure (Mpa)	28	
	Motor displacement (ml/r) (Front/Rear)	38/38	
Functional system	Model		Open system
	Pump displacement (ml/r)		16
	Lifting system	Max working Pressure (Mpa)	20
	Steering system	Max working Pressure (Mpa)	13.8

### Electrical System

Item	Specification/Content	
Battery	Output voltage (V)	12
	Capacity (AH)	120(20 hours)
Control system	Voltage (V)	12

### Fueling Capacity



**Note:** When hydraulic oil and diesel are filled, it is necessary to use the corresponding hydraulic oil and diesel according to operating environment and temperature, and refer to the following contents:

Item	Condition	Type	Capacity	Remarks
Hydraulic oil(L)	-25°C < Minimum Ambient temperature	L-HV 32 low temperature hydraulic oil	140	Recommended Chevron
	-40°C < Minimum Ambient temperature ≤ -25°C	L-HS 32ultralow temperature hydraulic oil		
	Minimum Ambient temperature ≤ -40°C	10# aviation hydraulic oil		
Driving Reducer oil (L)	30°C < The lowest temperature	85W/140	0.68 × 4	API GL-5
	-10°C < The lowest temperature < 30°C	85W/90		
	-30°C < The lowest temperature < -10°C	80W/90		
	The lowest temperature < -30°C	75W		
Engine oil(L)	Working temperature: -20°C ~ 40°C	15W-40	8.5	API CJ-4
	Working temperature: -25°C ~ 30°C	10W-30		
	Working temperature: -30°C ~ 30°C	5W-30		
	Working temperature: -35°C ~ 20°C	0W-20		
Diesel (L)	Ambient temperature ≥ 4°C	0 #Diesel	100	ULSD

	Ambient temperature $\geq$ -5 $^{\circ}$ C	-10 #Diesel		
	Ambient temperature $\geq$ -14 $^{\circ}$ C	-20 Diesel		
	Ambient temperature $\geq$ -29 $^{\circ}$ C	-35 Diesel		
Antifreeze (L)	/	50% LLC/50% clean soft water	8.5	

**Specifications**

**Parameters of SR1023D (S10230NDCH20) Whole Machine**

**Performance Parameters of Whole Machine**

Item	Parameters	Item	Parameters
Rated load (kg)	1100	Ascending/descending speed (s)	45/45
Load of extension platform (kg)	230	Minimum turning radius (outer wheel) (m)	5.33
Maximum number of workers	7	Maximum allowable angle of operation (front and rear)	3°
Maximum working height (m)	12	Maximum allowable angle of operation (left and right)	2°
Maximum platform height (m)	10	Maximum leveling angle of outrigger (from front to rear)	7°
Extension dimension of front platform (m)	1.45	Maximum leveling angle of outrigger (from left to right)	12°
Extension dimension of rear platform	1.14	Theoretical climbing ability (mm)	40%
Running speed of machine (folding state) (km/h)	6.1	Running height (m)	10
Running speed of machine (rising state) (km/h)	1.1		

**Main Dimensions**

Item	Parameters	Item	Parameters
Length of whole machine - platform retraction (m)	4.9	Extension length - double extension length (m)	6.58
Width of whole machine (m)	2.3	Wheel base (front/rear) (mm)	2,850
Height of whole machine - unfolded guard railing (m)	2.74	Thread (mm)	1,993
Height of whole machine - folded guard railing (m)	2.06	Ground clearance (folding state) (m)	0.23
Dimension of main platform (length x width) (m)	3.98x1.83	Tire specification (diameter x width)	835x290
Extension length - single extension length (m)	5.44	Weight of whole machine (kg)	6805

**Main Dimensions-7.2m platform (If equipped)**

Item	Parameters	Item	Parameters
Length of whole machine - platform retraction (m)	4.9	Extension length - double extension length (m)	6.58
Width of whole machine (m)	2.3	Wheel base (front/rear) (mm)	2,850
Height of whole machine - unfolded guard railing (m)	3.18	Thread (mm)	1,993
Height of whole machine - folded guard railing (m)	2.5	Ground clearance (folding state) (m)	0.23
Dimension of main platform	4.61x1.83	Tire specification (diameter x	835x290

(length x width) (m)		width)	
Extension length - single extension length (m)	6.07	Weight of whole machine (kg)	6865

**Engine System**

Item	Parameters/Contents	Item	Parameters/Contents
Model	D2011L03i	Number of cylinder	3
Rated power (/KW)	36.3	Type	In-line, Air-cooling and four-stroke
Rated speed (r/min)	2,800	Maximum torque (N.m)/speed (r/min)	137/1,700
Displacement (ml)	2,331	Emission standard	EU III

**Hydraulic System**

Item	Parameters/Contents
Type	Open lifting system and closing walking system
Lifting pump	Gear pump with displacement of 16 ml/r
Walking pump	Closed variable pump with displacement of 49 ml/r
System pressure (MPa)	28
Walking motor	Piston motor with displacement of 38 ml/r

**Refueling Volume**

Item	Parameters
Hydraulic oil	140 L (replacement of oil)
Engine oil (CH-4 15W-40)	7.5L
Diesel	110L
Reducer (4) 80-90/w	0.68L*4

Note: When hydraulic oil and diesel are filled, it is necessary to use the corresponding hydraulic oil and diesel according to operating environment and temperature, and refer to the following contents :

- L-HV 32 low temperature hydraulic oil:  $-25^{\circ}\text{C} < \text{minimum air temperature}$
- L-HS 32 Ultralow temperature hydraulic oil:  $-40^{\circ}\text{C} < \text{minimum air temperature} \leq -25^{\circ}\text{C}$
- 10# aviation hydraulic oil:  $\text{minimum air temperature} \leq -40^{\circ}\text{C}$ ;  
Engine oil type(15W-40). Engine oil type-cold condition(5W-30).

Air temperature	Diesel
air temperature $\geq 4^{\circ}\text{C}$	0 #Diesel
air temperature $\geq -5^{\circ}\text{C}$	-10 #Diesel
air temperature $\geq -14^{\circ}\text{C}$	-20# Diesel
air temperature $\geq -29^{\circ}\text{C}$	-35 #Diesel

**Specifications**

**Parameters of SR1323D (S13230NDCH20) Whole Machine**

**Performance Parameters of Whole Machine**

Item	Parameters	Item	Parameters
Rated load (kg)	910	Ascending/descending speed (s)	55/55
Load of extension platform (kg)	230	Minimum turning radius (outer wheel) (m)	5.33
Maximum number of workers	7	Maximum allowable angle of operation (front and rear)	3°
Maximum working height (m)	15	Maximum allowable angle of operation (left and right)	2°
Maximum platform height (m)	13	Maximum leveling angle of outrigger (from front to rear)	7°
Extension dimension of front platform (m)	1.45	Maximum leveling angle of outrigger (from left to right)	12°
Extension dimension of rear platform	1.14	Theoretical climbing ability (mm)	40%
Running speed of machine (folding state) (km/h)	6.1	Running height (m)	8.5
Running speed of machine (rising state) (km/h)	1.1		

**Main Dimensions**

Item	Parameters	Item	Parameters
Length of whole machine - platform retraction (m)	4.9	Extension length - double extension length (m)	6.58
Width of whole machine (m)	2.3	Wheel base (front/rear) (mm)	2,850
Height of whole machine - unfolded guard railing (m)	2.96	Thread (mm)	1,993
Height of whole machine - folded guard railing (m)	2.28	Ground clearance (folding state) (m)	0.23
Dimension of main platform (length x width) (m)	3.98x1.83	Tire specification (diameter x width)	835x290
Extension length - single extension length (m)	5.44	Weight of whole machine (kg)	7275

**Main Dimensions-7.2m platform (If equipped)**

Item	Parameters	Item	Parameters
Length of whole machine - platform retraction (m)	4.9	Extension length - double extension length (m)	7.21
Width of whole machine (m)	2.3	Wheel base (front/rear) (mm)	2,850
Height of whole machine - unfolded guard railing (m)	3.18	Thread (mm)	1,993
Height of whole machine - folded guard railing (m)	2.5	Ground clearance (folding state) (m)	0.23
Dimension of main platform	4.61x1.83	Tire specification (diameter x	835x290

(length x width) (m)		width)	
Extension length - single extension length (m)	6.07	Weight of whole machine (kg)	7335

**Engine System**

Item	Parameters/Contents	Item	Parameters/Contents
Model	D2011L03i	Number of cylinder	3
Rated power (KW)	36.3	Type	In-line, Air-cooling and four-stroke
Rated speed (r/min)	2,800	Maximum torque (N.m)/speed (r/min)	137/1,700
Displacement (ml)	2,331	Emission standard	EU III

**Hydraulic System**

Item	Parameters/Contents
Type	Open lifting system and closing walking system
Lifting pump	Gear pump with displacement of 16 ml/r
Walking pump	Closed variable pump with displacement of 49 ml/r
System pressure (MPa)	28
Walking motor	Piston motor with displacement of 38 ml/r

**Refueling Volume**

Item	Parameters
Hydraulic oil	140 L (replacement of oil)
Engine oil (CH-4 15W-40)	7.5L
Diesel	110L
Reducer (4) 80-90/w	0.68L*4

Note: When hydraulic oil and diesel are filled, it is necessary to use the corresponding hydraulic oil and diesel according to operating environment and temperature, and refer to the following contents :

- L-HV 32 low temperature hydraulic oil:  $-25^{\circ}\text{C} < \text{minimum air temperature}$
- L-HS 32 Ultralow temperature hydraulic oil:  $-40^{\circ}\text{C} < \text{minimum air temperature} \leq -25^{\circ}\text{C}$
- 10# aviation hydraulic oil:  $\text{minimum air temperature} \leq -40^{\circ}\text{C}$ ;

Engine oil type(15W-40). Engine oil type-cold condition(5W-30).

Air temperature	Diesel
air temperature $\geq 4^{\circ}\text{C}$	0 #Diesel
air temperature $\geq -5^{\circ}\text{C}$	-10 #Diesel
air temperature $\geq -14^{\circ}\text{C}$	-20# Diesel
air temperature $\geq -29^{\circ}\text{C}$	-35 #Diesel

**Specifications**

**Parameters of SR1623D (S16230NDCH21) Whole Machine**

**Performance Parameters of Whole Machine**

Item	Parameters	Item	Parameters
Rated load (kg)	680	Running height (m)	8.5
Load of extension platform (kg)	230	Ascending/descending speed (s)	55/55
Maximum number of workers	4	Minimum turning radius (inner wheel) (m)	2.57
Maximum working height (m)	18	Minimum turning radius (outer wheel) (m)	5.33
Maximum platform height (m)	16	Maximum allowable angle of operation (front and rear)	3°
Extension dimension of front platform (m)	1.45	Maximum allowable angle of operation (left and right)	2°
Extension dimension of rear platform	1.14	Maximum leveling angle of outrigger (from front to rear)	7°
Running speed of machine (folding state) (km/h)	6.1	Maximum leveling angle of outrigger (from left to right)	12°
Running speed of machine (rising state) (km/h)	1.1	Theoretical climbing ability (mm)	40%

**Main Dimensions**

Item	Parameters	Item	Parameters
Length of whole machine - platform retraction (m)	4.9	Height of platform - whole vehicle storage (m)	2.08
Width of whole machine (m)	2.3	Wheel base (front/rear) (mm)	2,850
Height of whole machine - unfolded guard railing (m)	3.18	Thread (mm)	1,993
Height of whole machine - folded guard railing (m)	2.5	Ground clearance (folding state) (m)	0.23
Dimension of main platform (length x width) (m)	3.98x1.83	Tire specification (diameter x width)	835x290
Extension length - single extension length (m)	5.44	Weight of whole machine (kg)	8,000
Extension length - double extension length (m)	6.58		

**Main Dimensions-7.2m platform (If equipped)**

Item	Parameters	Item	Parameters
Length of whole machine - platform retraction (m)	4.9	Height of platform - whole vehicle storage (m)	2.08
Width of whole machine (m)	2.3	Wheel base (front/rear) (mm)	2,850
Height of whole machine - unfolded guard railing (m)	3.18	Thread (mm)	1,993
Height of whole machine - folded guard railing (m)	2.5	Ground clearance (folding state) (m)	0.23

Dimension of main platform (length × width) (m)	4.61×1.83	Tire specification (diameter × width)	835×290
Extension length - single extension length (m)	6.07	Weight of whole machine (kg)	8060
Extension length - double extension length (m)	7.21		

**Engine System**

Item	Parameters/Contents	Item	Parameters/Contents
Model	D2011L03i	Number of cylinder	3
Rated power (/KW)	36.3	Type	In-line, Air-cooling and four-stroke
Rated speed (r/min)	2,800	Maximum torque (N.m)/speed (r/min)	137/1,700
Displacement (ml)	2,331	Emission standard	EU III

**Hydraulic System**

Item	Parameters/Contents
Type	Open lifting system and closing walking system
Lifting pump	Gear pump with displacement of 16 ml/r
Walking pump	Closed variable pump with displacement of 49 ml/r
System pressure (MPa)	28
Walking motor	Piston motor with displacement of 38 ml/r

**Refueling Volume**

Item	Parameters
Hydraulic oil	140 L (replacement of oil)
Engine oil (CH-4 15W-40)	7.5L
Diesel	110L
Reducer (4) 80-90/w	0.68L*4

Note: When hydraulic oil and diesel are filled, it is necessary to use the corresponding hydraulic oil and diesel according to operating environment and temperature, and refer to the following contents:

- L-HV 32 low temperature hydraulic oil:  $-25^{\circ}\text{C} < \text{minimum air temperature}$
- L-HS 32 Ultralow temperature hydraulic oil:  $-40^{\circ}\text{C} < \text{minimum air temperature} \leq -25^{\circ}\text{C}$
- 10# aviation hydraulic oil:  $\text{minimum air temperature} \leq -40^{\circ}\text{C}$ ;

Engine oil type(15W-40). Engine oil type-cold condition(5W-30).



Air temperature	Diesel
air temperature $\geq 4^{\circ}\text{C}$	0 #Diesel
air temperature $\geq -5^{\circ}\text{C}$	-10 #Diesel
air temperature $\geq -14^{\circ}\text{C}$	-20# Diesel
air temperature $\geq -29^{\circ}\text{C}$	-35 #Diesel

**Specifications**

**Parameters of SR1023D (S102301WND3CH2000) Whole Machine**

**Performance Parameters of Whole Machine**

Item	Parameters	Item	Parameters
Rated load (kg)	1100	Ascending speed (s)	45
Load of extension platform (kg)	230	Descending speed (s)	45
Weight of whole machine (kg)	6805	Theoretical climbing ability (mm)	40%
Maximum number of workers	7	Maximum allowable angle of operation (front and rear)	3°
Maximum working height (m)	12	Maximum allowable angle of operation (left and right)	2°
Maximum platform height (m)	10	Maximum leveling angle of outrigger (from front to rear)	7°
Minimum turning radius (outer wheel) (m)	5.33	Maximum leveling angle of outrigger (from left to right)	12°
Running speed of machine (folding state) (km/h)	6.1±0.2	Maximum wind speed (m/s)	12.5
Running speed of machine (rising state) (km/h)	1.1±0.1		

**Main Dimensions**

Item	Parameters	Item	Parameters
Length of whole machine (mm)	4900	Extending size of platform(mm)	1450/1140
Width of whole machine (mm)	2300	Wheel base (front/rear) (mm)	2850
Height of whole machine - unfolded guard railing (mm)	2740	Thread (mm)	1993
Height of whole machine - folded guard railing (mm)	2060	Ground clearance (mm)	210
Dimension of main platform (length x width) (mm)	3980x1830	Tire specification (diameter x width)	835x290

**Engine System**

Item	Parameters/Contents	Item	Parameters/Contents
Model	D2011L03i	Rated speed (r/min)	2,800
Rated power (KW)	36.3	Maximum torque (N.m)	137
Displacement (ml)	2331	Emission standard	EU stage III

**Drive system**

Item	Specification/Content
Driving reducer	Output torque (N*m) 7000

**Hydraulic System**

Item	Specification/Content
Driving system	Model Closed system

	Pump displacement (ml/r)	46	
	Max working Pressure (Mpa)	28	
	Motor displacement (ml/r) (Front/Rear)	38/38	
Functional system	Model		Open system
	Pump displacement (ml/r)		16
	Lifting system	Max working Pressure (Mpa)	20
	Steering system	Max working Pressure (Mpa)	13.8

**Electrical System**

Item	Specification/Content	
Battery	Output voltage (V)	12
	Capacity (AH)	120(20 hours)
Control system	Voltage (V)	12

**Fueling Capacity**



**Note:** When hydraulic oil and diesel are filled, it is necessary to use the corresponding hydraulic oil and diesel according to operating environment and temperature, and refer to the following contents:

Item	Condition	Type	Capacity	Remarks
Hydraulic oil(L)	-25°C < Minimum Ambient temperature	L-HV 32 low temperature hydraulic oil	140	Recommended Chevron
	-40°C < Minimum Ambient temperature ≤ -25°C	L-HS 32ultralow temperature hydraulic oil		
	Minimum Ambient temperature ≤ -40°C	10# aviation hydraulic oil		
Driving Reducer oil (L)	30° C < The lowest temperature	85W/140	0.68 × 4	API GL-5
	-10° C < The lowest temperature < 30° C	85W/90		
	-30° C < The lowest temperature < -10° C	80W/90		
	The lowest temperature < -30° C	75W		
Engine oil(L)	Working temperature: -20°C ~ 40°C	15W-40	7.5	API CH-4
	Working temperature: -25°C ~ 30°C	10W-30		
	Working temperature: -30°C ~ 30°C	5W-30		
	Working temperature: -35°C ~ 20°C	0W-20		

Diesel (L)	Ambient temperature $\geq$ 4 $^{\circ}$ C	0 #Diesel	110	
	Ambient temperature $\geq$ -5 $^{\circ}$ C	-10 #Diesel		
	Ambient temperature $\geq$ -14 $^{\circ}$ C	-20 Diesel		
	Ambient temperature $\geq$ -29 $^{\circ}$ C	-35 Diesel		

**Specifications**

**Parameters of SR1323D (S132301WND3CH2000) Whole Machine**

**Performance Parameters of Whole Machine**

Item	Parameters	Item	Parameters
Rated load (kg)	910	Ascending speed (s)	55
Load of extension platform (kg)	230	Descending speed (s)	55
Weight of whole machine (kg)	7275	Theoretical climbing ability (mm)	40%
Maximum number of workers	7	Maximum allowable angle of operation (front and rear)	3°
Maximum working height (m)	15	Maximum allowable angle of operation (left and right)	2°
Maximum platform height (m)	13	Maximum leveling angle of outrigger (from front to rear)	7°
Minimum turning radius (outer wheel) (m)	5.33	Maximum leveling angle of outrigger (from left to right)	12°
Running speed of machine (folding state) (km/h)	6.1±0.2	Maximum wind speed (m/s)	12.5
Running speed of machine (rising state) (km/h)	1.1±0.1		

**Main Dimensions**

Item	Parameters	Item	Parameters
Length of whole machine (mm)	4900	Extending size of platform(mm)	1450/1140
Width of whole machine (mm)	2300	Wheel base (front/rear) (mm)	2850
Height of whole machine - unfolded guard railing (mm)	2960	Thread (mm)	1993
Height of whole machine - folded guard railing (mm)	2280	Ground clearance (mm)	210
Dimension of main platform (length x width) (mm)	3980x1830	Tire specification (diameter xwidth)	835x290

**Engine System**

Item	Parameters/Contents	Item	Parameters/Contents
Model	D2011L03i	Rated speed (r/min)	2800
Rated power (KW)	36.3	Maximum torque (N.m)	137
Displacement (ml)	2331	Emission standard	EU stage III

**Drive system**

Item	Specification/Content
Driving reducer	Output torque (N*m) 7000

**Hydraulic System**

Item	Specification/Content
Driving system	Model Closed system

	Pump displacement (ml/r)	46	
	Max working Pressure (Mpa)	28	
	Motor displacement (ml/r) (Front/Rear)	38/38	
Functional system	Model		Open system
	Pump displacement (ml/r)		16
	Lifting system	Max working Pressure (Mpa)	20
	Steering system	Max working Pressure (Mpa)	13.8

**Electrical System**

Item	Specification/Content	
Battery	Output voltage (V)	12
	Capacity (AH)	120(20 hours)
Control system	Voltage (V)	12

**Fueling Capacity**



**Note:** When hydraulic oil and diesel are filled, it is necessary to use the corresponding hydraulic oil and diesel according to operating environment and temperature, and refer to the following contents:

Item	Condition	Type	Capacity	Remarks
Hydraulic oil(L)	-25°C < Minimum Ambient temperature	L-HV 32 low temperature hydraulic oil	140	Recommended Chevron
	-40°C < Minimum Ambient temperature ≤ -25°C	L-HS 32ultralow temperature hydraulic oil		
	Minimum Ambient temperature ≤ -40°C	10# aviation hydraulic oil		
Driving Reducer oil (L)	30° C < The lowest temperature	85W/140	0.68 × 4	API GL-5
	-10° C < The lowest temperature < 30° C	85W/90		
	-30° C < The lowest temperature < -10° C	80W/90		
	The lowest temperature < -30° C	75W		
Engine oil(L)	Working temperature: -20°C ~ 40°C	15W-40	7.5	API CH-4
	Working temperature: -25°C ~ 30°C	10W-30		
	Working temperature: -30°C ~ 30°C	5W-30		
	Working temperature: -35°C ~ 20°C	0W-20		

Diesel (L)	Ambient temperature $\geq$ 4 $^{\circ}$ C	0 #Diesel	110	
	Ambient temperature $\geq$ -5 $^{\circ}$ C	-10 #Diesel		
	Ambient temperature $\geq$ -14 $^{\circ}$ C	-20 Diesel		
	Ambient temperature $\geq$ -29 $^{\circ}$ C	-35 Diesel		

**Specifications**

**Parameters of SR1623D (S162301WND3CH2000) Whole Machine**

**Performance Parameters of Whole Machine**

Item	Parameters	Item	Parameters
Rated load (kg)	680	Ascending speed (s)	55
Load of extension platform (kg)	230	descending speed (s)	55
Weight of whole machine (kg)	8000	Theoretical climbing ability (mm)	40%
Maximum number of workers	4	Maximum leveling angle of outrigger (from left to right)	12°
Maximum working height (m)	17.9	Maximum leveling angle of outrigger (from front to rear)	7°
Maximum platform height (m)	15.9	Maximum allowable angle of operation (front and rear)	3°
Minimum turning radius (outer wheel) (m)	5.33	Maximum allowable angle of operation (left and right)	2°
Running speed of machine (folding state) (km/h)	6.1±0.2	Maximum wind speed (m/s)	12.5
Running speed of machine (rising state) (km/h)	1.1±0.1		

**Main Dimensions**

Item	Parameters	Item	Parameters
Length of whole machine (mm)	4900	Extending size of platform(mm)	1450/1140
Width of whole machine (mm)	2300	Wheel base (front/rear) (mm)	2850
Height of whole machine - unfolded guard railing (mm)	3180	Thread (mm)	1993
Height of whole machine - folded guard railing (mm)	2500	Ground clearance (mm)	210
Dimension of main platform (length x width) (mm)	3980x1830	Tire specification (diameter x width)	835x290

**Engine System**

Item	Parameters/Contents	Item	Parameters/Contents
Model	D2011L03i	Rated speed (r/min)	2800
Rated power (KW)	36.3	Maximum torque (N.m)/	137
Displacement (ml)	2331	Emission standard	EU stage III

**Drive system**

Item	Specification/Content
Driving reducer	Output torque (N*m) 7000

**Hydraulic System**

Item	Specification/Content
Driving system	Model Closed system



	Pump displacement (ml/r)	46	
	Max working Pressure (Mpa)	28	
	Motor displacement (ml/r) (Front/Rear)	38/38	
Functional system	Model		Open system
	Pump displacement (ml/r)		16
	Lifting system	Max working Pressure (Mpa)	20
	Steering system	Max working Pressure (Mpa)	13.8

**Electrical System**

Item	Specification/Content	
Battery	Output voltage (V)	12
	Capacity (AH)	120(20 hours)
Control system	Voltage (V)	12

**Fueling Capacity**



**Note:** When hydraulic oil and diesel are filled, it is necessary to use the corresponding hydraulic oil and diesel according to operating environment and temperature, and refer to the following contents:

Item	Condition	Type	Capacity	Remarks
Hydraulic oil(L)	-25°C < Minimum Ambient temperature	L-HV 32 low temperature hydraulic oil	140	Recommended Chevron
	-40°C < Minimum Ambient temperature ≤ -25°C	L-HS 32ultralow temperature hydraulic oil		
	Minimum Ambient temperature ≤ -40°C	10# aviation hydraulic oil		
Driving Reducer oil (L)	30°C < The lowest temperature	85W/140	0.68 × 4	API GL-5
	-10°C < The lowest temperature < 30°C	85W/90		
	-30°C < The lowest temperature < -10°C	80W/90		
	The lowest temperature < -30°C	75W		
Engine oil(L)	Working temperature: -20°C ~ 40°C	15W-40	7.5	API CH-4
	Working temperature: -25°C ~ 30°C	10W-30		
	Working temperature: -30°C ~ 30°C	5W-30		
	Working temperature: -35°C ~ 20°C	0W-20		
Diesel (L)	Ambient temperature ≥ 4°C	0 #Diesel	110	

---

	Ambient temperature $\geq$ -5 $^{\circ}$ C	-10 #Diesel		
	Ambient temperature $\geq$ -14 $^{\circ}$ C	-20 Diesel		
	Ambient temperature $\geq$ -29 $^{\circ}$ C	-35 Diesel		

**Specifications**

**Parameters of SR1023D (S102301WNK3QH2000) Whole Machine**

**Performance Parameters of Whole Machine**

Item	Parameters	Item	Parameters
Rated load (kg)	1100	Ascending speed (s)	45
Load of extension platform (kg)	230	Descending speed (s)	45
Weight of whole machine (kg)	6885	Theoretical climbing ability (mm)	40%
Maximum number of workers	7	Maximum allowable angle of operation (front and rear)	3°
Maximum working height (m)	12	Maximum allowable angle of operation (left and right)	2°
Maximum platform height (m)	10	Maximum leveling angle of outrigger (from front to rear)	7°
Minimum turning radius (outer wheel) (m)	5.33	Maximum leveling angle of outrigger (from left to right)	12°
Running speed of machine (folding state) (km/h)	6.1±0.2	Maximum wind speed (m/s)	12.5
Running speed of machine (rising state) (km/h)	1.1±0.1	Running height (m)	10

**Main Dimensions**

Item	Parameters	Item	Parameters
Length of whole machine (mm)	4900	Extending size of platform(mm)	1450/1140
Width of whole machine (mm)	2300	Wheel base (front/rear) (mm)	2850
Height of whole machine - unfolded guard railing (mm)	2740	Thread (mm)	1993
Height of whole machine - folded guard railing (mm)	2060	Ground clearance (mm)	230
Dimension of main platform (length x width) (mm)	4810x1830	Tire specification (diameter x width)	835x290

**Engine System**

Item	Parameters/Contents	Item	Parameters/Contents
Model	V2403-M-DI-ET04e	Rated speed (r/min)	2600
Rated power (KW)	36	Maximum torque (N.m)	156.3
Displacement (ml)	2434	Emission standard	EU stage III

**Drive system**

Item	Specification/Content
Driving reducer	Output torque (N*m) 7000

**Hydraulic System**

Item	Specification/Content
Driving system	Model Closed system

	Pump displacement (ml/r)	46	
	Max working Pressure (Mpa)	28	
	Motor displacement (ml/r) (Front/Rear)	38/38	
Functional system	Model		Open system
	Pump displacement (ml/r)		16
	Lifting system	Max working Pressure (Mpa)	20
	Steering system	Max working Pressure (Mpa)	13.8

### Electrical System

Item	Specification/Content	
Battery	Output voltage (V)	12
	Capacity (AH)	120(20 hours)
Control system	Voltage (V)	12

### Fueling Capacity



**Note:** When hydraulic oil and diesel are filled, it is necessary to use the corresponding hydraulic oil and diesel according to operating environment and temperature, and refer to the following contents:

Item	Condition	Type	Capacity	Remarks
Hydraulic oil(L)	-25°C < Minimum Ambient temperature	L-HV 32 low temperature hydraulic oil	140	Recommended Chevron
	-40°C < Minimum Ambient temperature ≤ -25°C	L-HS 32ultralow temperature hydraulic oil		
	Minimum Ambient temperature ≤ -40°C	10# aviation hydraulic oil		
Driving Reducer oil (L)	30° C < The lowest temperature	85W/140	0.68 × 4	API GL-5
	-10° C < The lowest temperature < 30° C	85W/90		
	-30° C < The lowest temperature < -10° C	80W/90		
	The lowest temperature < -30° C	75W		
Engine oil(L)	Working temperature: -20°C ~ 40°C	15W-40	8	API CH-4
	Working temperature: -25°C ~ 30°C	10W-30		
	Working temperature: -30°C ~ 30°C	5W-30		
	Working temperature: -35°C ~ 20°C	0W-20		

Diesel (L)	Ambient temperature $\geq 4^{\circ}\text{C}$	0 #Diesel	100	
	Ambient temperature $\geq -5^{\circ}\text{C}$	-10 #Diesel		
	Ambient temperature $\geq -14^{\circ}\text{C}$	-20 Diesel		
	Ambient temperature $\geq -29^{\circ}\text{C}$	-35 Diesel		
Antifreeze (L)	/	50% LLC/50% clean soft water	6.4	

**Specifications**

**Parameters of SR1323D (S132301WNK3QH2000) Whole Machine**

**Performance Parameters of Whole Machine**

Item	Parameters	Item	Parameters
Rated load (kg)	910	Ascending speed (s)	55
Load of extension platform (kg)	230	Descending speed (s)	55
Weight of whole machine (kg)	7355	Theoretical climbing ability (mm)	40%
Maximum number of workers	7	Maximum allowable angle of operation (front and rear)	3°
Maximum working height (m)	15	Maximum allowable angle of operation (left and right)	2°
Maximum platform height (m)	13	Maximum leveling angle of outrigger (from front to rear)	7°
Minimum turning radius (outer wheel) (m)	5.33	Maximum leveling angle of outrigger (from left to right)	12°
Running speed of machine (folding state) (km/h)	6.1±0.2	Maximum wind speed (m/s)	12.5
Running speed of machine (rising state) (km/h)	1.1±0.1	Running height (m)	8.5

**Main Dimensions**

Item	Parameters	Item	Parameters
Length of whole machine (mm)	4900	Extending size of platform(mm)	1450/1140
Width of whole machine (mm)	2300	Wheel base (front/rear) (mm)	2850
Height of whole machine - unfolded guard railing (mm)	2960	Thread (mm)	1993
Height of whole machine - folded guard railing (mm)	2280	Ground clearance (mm)	230
Dimension of main platform (length x width) (mm)	4810x1830	Tire specification (diameter xwidth)	835x290

**Engine System**

Item	Parameters/Contents	Item	Parameters/Contents
Model	V2403-M-DI-ET04e	Rated speed (r/min)	2600
Rated power (KW)	36	Maximum torque (N.m)	156.3
Displacement (ml)	2434	Emission standard	EU stage III

**Drive system**

Item	Specification/Content
Driving reducer	Output torque (N*m) 7000

**Hydraulic System**

Item	Specification/Content
Driving system	Model Closed system

	Pump displacement (ml/r)	46	
	Max working Pressure (Mpa)	28	
	Motor displacement (ml/r) (Front/Rear)	38/38	
Functional system	Model		Open system
	Pump displacement (ml/r)		16
	Lifting system	Max working Pressure (Mpa)	20
	Steering system	Max working Pressure (Mpa)	13.8

### Electrical System

Item	Specification/Content	
Battery	Output voltage (V)	12
	Capacity (AH)	120 (20 hours)
Control system	Voltage (V)	12

### Fueling Capacity



**Note:** When hydraulic oil and diesel are filled, it is necessary to use the corresponding hydraulic oil and diesel according to operating environment and temperature, and refer to the following contents:

Item	Condition	Type	Capacity	Remarks
Hydraulic oil(L)	-25°C < Minimum Ambient temperature	L-HV 32 low temperature hydraulic oil	140	Recommended Chevron
	-40°C < Minimum Ambient temperature ≤ -25°C	L-HS 32ultralow temperature hydraulic oil		
	Minimum Ambient temperature ≤ -40°C	10# aviation hydraulic oil		
Driving Reducer oil (L)	30° C < The lowest temperature	85W/140	0.68 × 4	API GL-5
	-10° C < The lowest temperature < 30° C	85W/90		
	-30° C < The lowest temperature < -10° C	80W/90		
	The lowest temperature < -30° C	75W		
Engine oil(L)	Working temperature: -20°C ~ 40°C	15W-40	8	API CH-4
	Working temperature: -25°C ~ 30°C	10W-30		
	Working temperature: -30°C ~ 30°C	5W-30		
	Working temperature: -35°C ~ 20°C	0W-20		

Diesel (L)	Ambient temperature $\geq$ 4 $^{\circ}$ C	0 #Diesel	100	
	Ambient temperature $\geq$ -5 $^{\circ}$ C	-10 #Diesel		
	Ambient temperature $\geq$ -14 $^{\circ}$ C	-20 Diesel		
	Ambient temperature $\geq$ -29 $^{\circ}$ C	-35 Diesel		
Antifreeze (L)	/	50% LLC/50% clean soft water	6.4	



**Specifications**

**Parameters of SR1623D (S162301WNK3QH2000) Whole Machine**

**Performance Parameters of Whole Machine**

Item	Parameters	Item	Parameters
Rated load (kg)	680	Ascending speed (s)	55
Load of extension platform (kg)	230	descending speed (s)	55
Weight of whole machine (kg)	8080	Theoretical climbing ability (mm)	40%
Maximum number of workers	4	Maximum leveling angle of outrigger (from left to right)	12°
Maximum working height (m)	17.9	Maximum leveling angle of outrigger (from front to rear)	7°
Maximum platform height (m)	15.9	Maximum allowable angle of operation (front and rear)	3°
Minimum turning radius (outer wheel) (m)	5.33	Maximum allowable angle of operation (left and right)	2°
Running speed of machine (folding state) (km/h)	6.1±0.2	Maximum wind speed (m/s)	12.5
Running speed of machine (rising state) (km/h)	1.1±0.1	Running height (m)	8.5

**Main Dimensions**

Item	Parameters	Item	Parameters
Length of whole machine (mm)	4900	Extending size of platform(mm)	1450/1140
Width of whole machine (mm)	2300	Wheel base (front/rear) (mm)	2850
Height of whole machine - unfolded guard railing (mm)	3180	Thread (mm)	1993
Height of whole machine - folded guard railing (mm)	2500	Ground clearance (mm)	210
Dimension of main platform (length x width) (mm)	4810x1830	Tire specification (diameter x width)	835x290

**Engine System**

Item	Parameters/Contents	Item	Parameters/Contents
Model	V2403-M-DI-ET04e	Rated speed (r/min)	2600
Rated power (KW)	36	Maximum torque (N.m)	156.3
Displacement (ml)	2434	Emission standard	EU stage III

**Drive system**

Item	Specification/Content
Driving reducer	Output torque (N*m) 7000

**Hydraulic System**

Item	Specification/Content
Driving system	Model Closed system

	Pump displacement (ml/r)	46	
	Max working Pressure (Mpa)	28	
	Motor displacement (ml/r) (Front/Rear)	38/38	
Functional system	Model		Open system
	Pump displacement (ml/r)		16
	Lifting system	Max working Pressure (Mpa)	20
	Steering system	Max working Pressure (Mpa)	13.8

**Electrical System**

Item	Specification/Content	
Battery	Output voltage (V)	12
	Capacity (AH)	120 (20 hours)
Control system	Voltage (V)	12

**Fueling Capacity**



**Note: When hydraulic oil and diesel are filled, it is necessary to use the corresponding hydraulic oil and diesel according to operating environment and temperature, and refer to the following contents:**

Item	Condition	Type	Capacity	Remarks
Hydraulic oil(L)	-25°C < Minimum Ambient temperature	L-HV 32 low temperature hydraulic oil	140	Recommended Chevron
	-40°C < Minimum Ambient temperature ≤ -25°C	L-HS 32ultralow temperature hydraulic oil		
	Minimum Ambient temperature ≤ -40°C	10# aviation hydraulic oil		
Driving Reducer oil (L)	30°C < The lowest temperature	85W/140	0.68 × 4	API GL-5
	-10°C < The lowest temperature < 30°C	85W/90		
	-30°C < The lowest temperature < -10°C	80W/90		
	The lowest temperature < -30°C	75W		
Engine oil(L)	Working temperature: -20°C ~ 40°C	15W-40	8	API CH-4
	Working temperature: -25°C ~ 30°C	10W-30		
	Working temperature: -30°C ~ 30°C	5W-30		
	Working temperature: -35°C ~ 20°C	0W-20		
Diesel (L)	Ambient temperature ≥ 4°C	0 #Diesel	100	

	Ambient temperature $\geq$ -5 $^{\circ}$ C	-10 #Diesel		
	Ambient temperature $\geq$ -14 $^{\circ}$ C	-20 Diesel		
	Ambient temperature $\geq$ -29 $^{\circ}$ C	-35 Diesel		
Antifreeze (L)	/	50% LLC/50% clean soft water	6.4	



## Chapter 5 Control Station



## 5.1 Ground Control Station

### 5.1.1 Ground Control Station-SR0818D/SR1018D/SR1218D

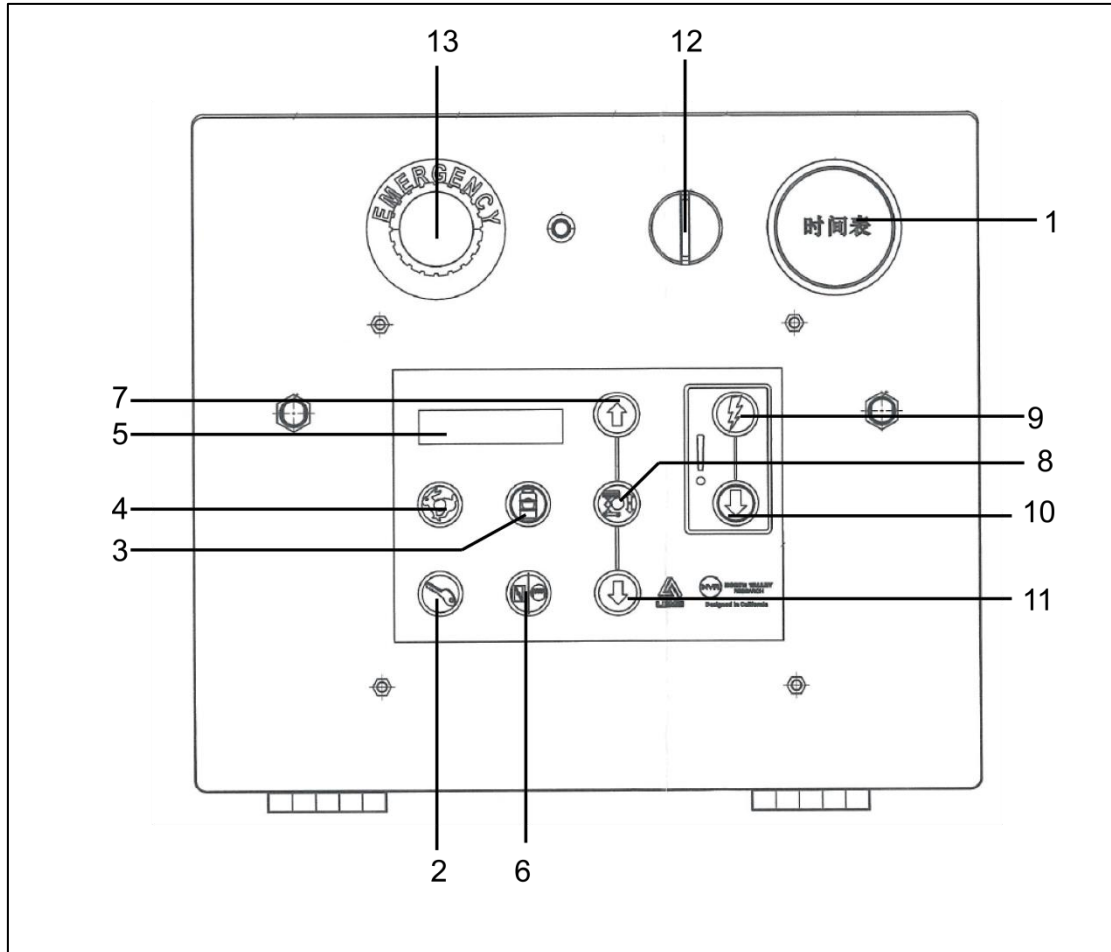

No.	Name	Operation function description
1	Timer (If equipped)	The timer displays hours that the machine has been running. The running time of machine can also be displayed by ground controller.
2	Startup button of engine	Press this button to start up the engine.
3	Gasoline/LPG model: LPG operating button with indicator	Press this button to select LPG.
4	Idling selection button of engine with indicator	Press this button to select the idling setting of engine. The indicator is on, indicating that the high idling has been selected. The indicator is off, indicating that the low idling has been selected.
5	LCD display	
6	Glow plug button	Press this button to activate the glow plug.
7	Lift button of platform	Press this button to lift the platform.

8	Enabling button with lift function	Press this button to activate the lift function.
9	Enabling button with standby auxiliary function	Press this button to activate the emergency descending function.
10	Standby auxiliary descending button	Press this button to activate the emergency lowering function.
11	Descending button of platform	Press this button to descend the platform.
12	Selection of key switch for platform/off/Ground Control Station	Turn the key switch to the platform, and then Platform Control Station will run. Turn the key switch to OFF position, and then the machine will be shut down. Turn the key switch to the ground, and then Ground Control Station will run.
13	Red "emergency shutdown" button	Push the red "emergency shutdown" button inward to Off position to stop all functions. Pull the red "emergency shutdown" button out to On position to operate the machine.



### 5.1.2 Ground Control Station (Second generation) -SR1023D/SR1323D/SR1623D

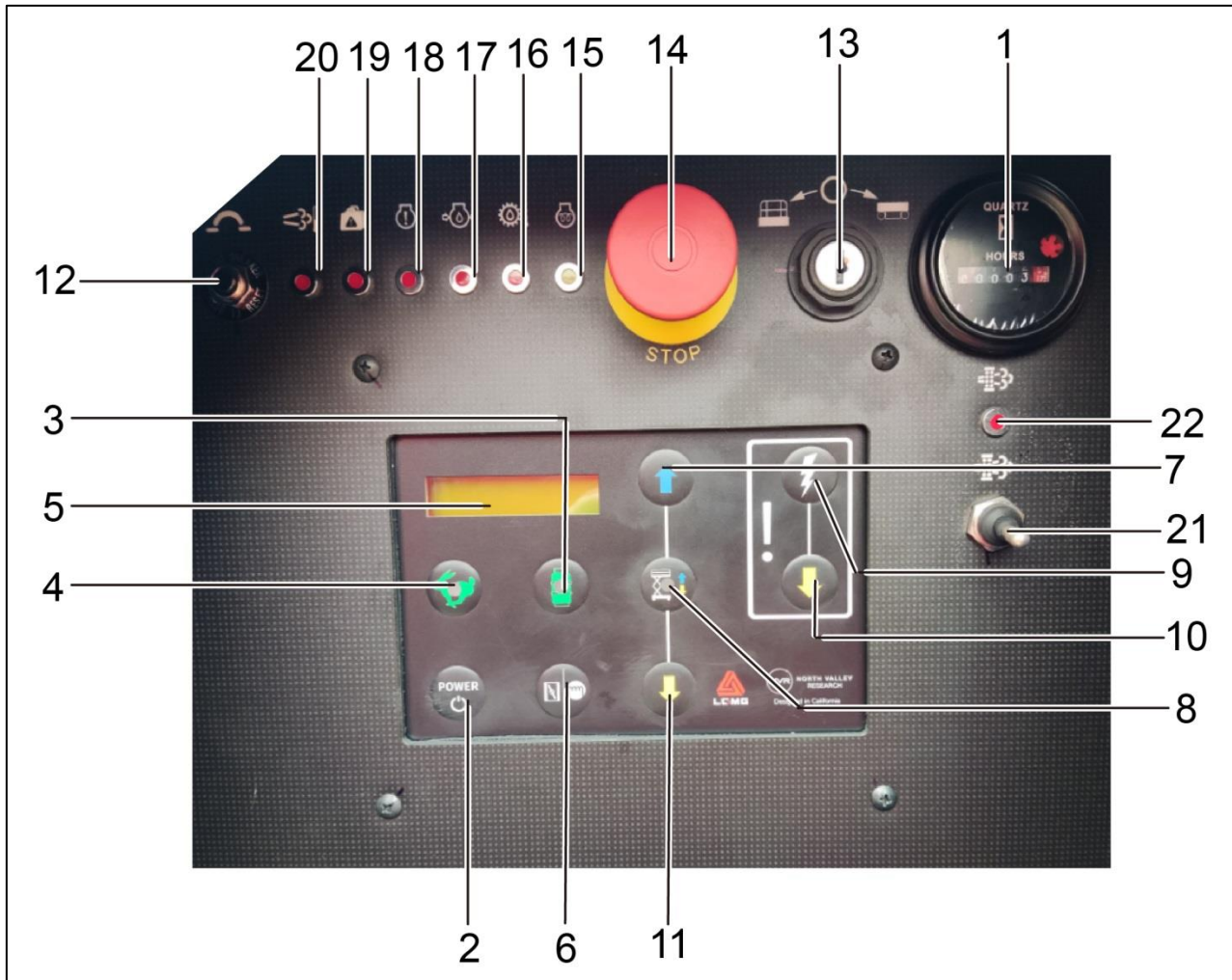

No.	Name	Operation function description
1	Timer (If equipped)	The timer displays hours that the machine has been running. The running time of machine can also be displayed by ground controller.
2	Startup button of engine	Press this button to start up the engine.
3	Gasoline/LPG model: LPG operating button with indicator	Press this button to select LPG.
4	Idling selection button of engine with indicator	Press this button to select the idling setting of engine. The indicator is on, indicating that the high idling has been selected. The indicator is off, indicating that the low idling has been selected.
5	LCD display	
6	Glow plug button	Press this button to activate the glow plug.
7	Lift button of platform	Press this button to lift the platform.
8	Enabling button with lift function	Press this button to activate the lift function.

9	Enabling button with standby auxiliary function	Press this button to activate the emergency descending function.
10	Standby auxiliary descending button	Press this button to activate the emergency lowering function.
11	Descending button of platform	Press this button to descend the platform.
12	Circuit breaker	
13	Selection of key switch for platform/off/Ground Control Station	Turn the key switch to the platform, and then Platform Control Station will run. Turn the key switch to OFF position, and then the machine will be shut down. Turn the key switch to the ground, and then Ground Control Station will run.
14	Red "emergency shutdown" button	Push the red "emergency shutdown" button inward to Off position to stop all functions. Pull the red "emergency shutdown" button out to On position to operate the machine.
15	Preheat indicator (If equipped)	
16	Water temperature indicator(If equipped)	
17	Engine oil pressure indicator(If equipped)	
18	Engine warning indicator(If equipped)	
19	Platform overload indicator(If equipped)	
20	Active regeneration indicator(If equipped)	
21	Regeneration button(If equipped)	
22	Parked regeneration request indicator(If equipped)	

### 5.1.3 Ground Control Station (Second generation) -SR1023D/SR1323D/SR1623D (If equipped)

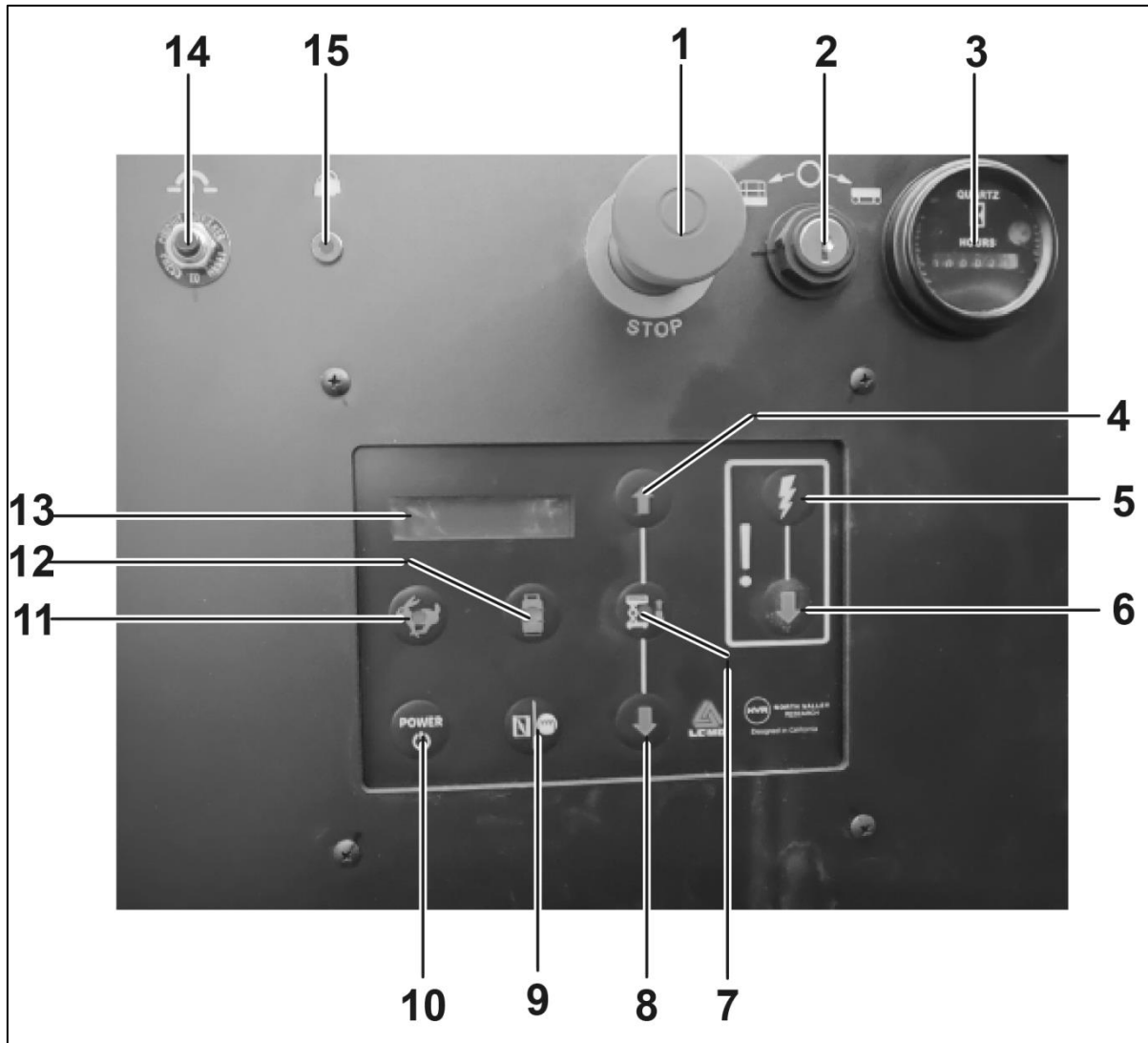

No.	Name	Operation function description
1	Red "emergency shutdown" button	Push the red "emergency shutdown" button inward to Off position to stop all functions. Pull the red "emergency shutdown" button out to On position to operate the machine.
2	Selection of key switch for platform/off/Ground Control Station	Turn the key switch to the platform, and then Platform Control Station will run. Turn the key switch to OFF position, and then the machine will be shut down. Turn the key switch to the ground, and then Ground Control Station will run.
3	Timer (If equipped)	The timer displays hours that the machine has been running. The running time of machine can also be displayed by ground controller.
4	Lift button of platform	Press this button to lift the platform.

5	Enabling button with standby auxiliary function	Press this button to activate the emergency descending function.
6	Standby auxiliary descending button	Press this button to activate the emergency lowering function.
7	Enabling button with lift function	Press this button to activate the lift function.
8	Descending button of platform	Press this button to descend the platform.
9	Glow plug button	Press this button to activate the glow plug.
10	Startup button of engine	Press this button to start up the engine.
11	Idling selection button of engine with indicator	Press this button to select the idling setting of engine. The indicator is on, indicating that the middle and high idling has been selected. The indicator is off, indicating that the middle and low idling has been selected.
12	Gasoline/LPG model: LPG operating button with indicator	Press this button to select LPG.
13	LCD display	
14	Circuit breaker	
15	Platform overload indicator	

### 5.1.4 GCU (First generation)-SR1023D/SR1323D/SR1623D

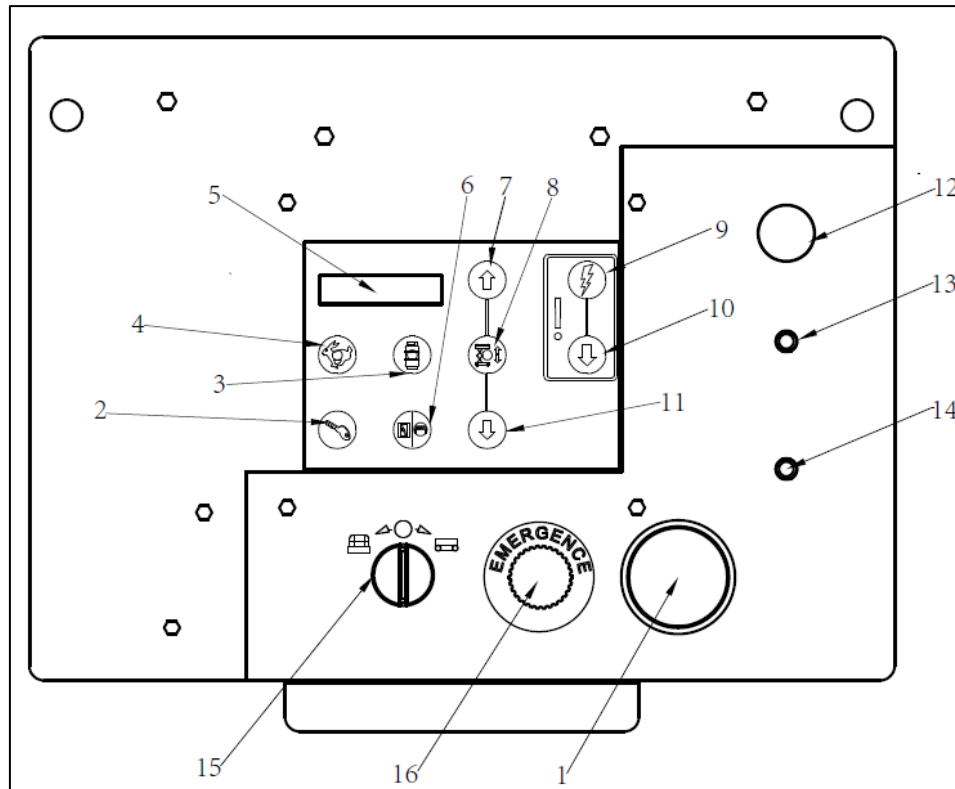

No.	Name	Operation function description
1	Timer(If equipped)	The timer displays hours that the machine has been running. The running time of machine can also be displayed by ground controller.
2	Startup button of engine	Press this button to start up the engine.
3	Gasoline/LPG model: LPG operating button with indicator	Press this button to select LPG.
4	Idling selection button of engine with indicator	Press this button to select the idling setting of engine. The indicator is on, indicating that the middle and high idling has been selected. The indicator is off, indicating that the middle and low idling has been selected.
5	LCD reading display	
6	Glow plug button	Press this button to activate the glow plug.
7	Ascending button of platform	Press this button to rise up the platform.
8	Enabling button with lifting function	Press this button to activate the lifting function.
9	Enabling button with standby auxiliary function	Press this button to activate the emergency descending function.
10	Standby auxiliary descending button	Press this button to activate the emergency lowering function.
11	Descending button of platform	Press this button to descend the platform.
12	Buzzer	

13	Circuit breaker	
14	Circuit breaker	
15	Selection of key switch for platform/off/GCU	Turn the key switch to the platform, and then PCU will run. Turn the key switch to OFF position, and then the machine will be shut down. Turn the key switch to the ground, and then GCU will run.
16	Red "emergency shutdown" button	Push the red "emergency shutdown" button inward to Off position to stop all functions. Pull the red "emergency shutdown" button out to On position to operate the machine.

## 5.2 PCU

### 5.2.1 PCU (If equipped)

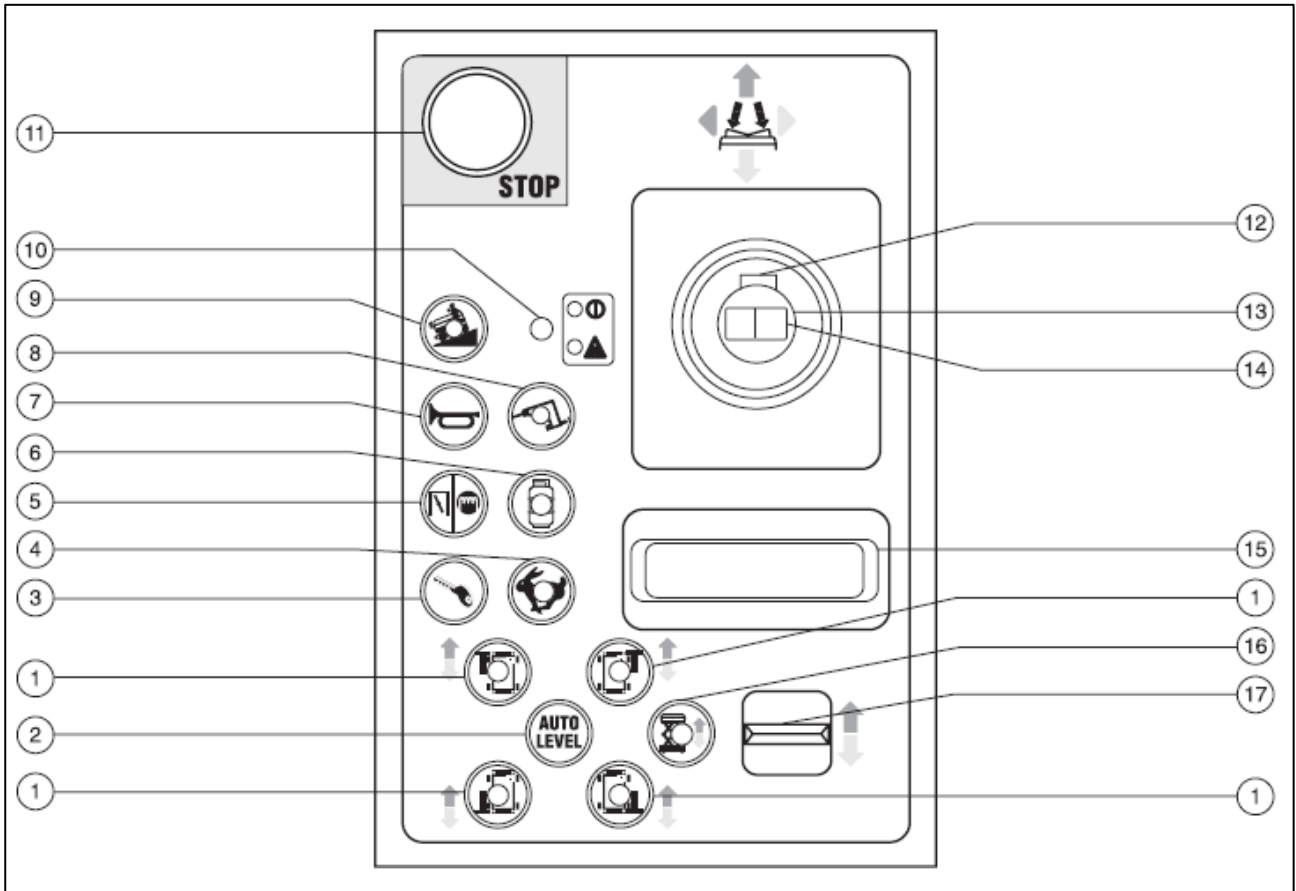

No.	Name	Operation function description
1	Functional enabling button of outrigger with indicator	Press this button to activate the ascending/descending functions of single outrigger.
2	Automatic leveling button of outrigger	Press this button to activate the automatic leveling function.
3	Startup button of engine	Press this button to start up the engine.
4	Idling selection button of engine with indicator	Press this button to select the idling setting of engine. The indicator is on, indicating that the high idling has been selected. The indicator is off, indicating that the intermediate and low idling has been selected.
5	Glow plug button	Press this button to activate the glow plug.
6	Gasoline/LPG model: LPG operating button with indicator	Press this button to select LPG.
7	Horn button	Press this button, and the horn will sound. Release this button, and the horn will stop sounding.

8	Reserve	
9	Machine inclination button with indicator: Please operate it at a low speed during inclination.	Press this button to perform operation at a low speed during inclination.
10	Green power lamp/red error power lamp	When the red emergency shutdown button is pulled out to On position, the green power lamp will be on. If the red error indicator is on, press and pull out the red emergency shutdown button to set the system. If the lamp is still red, mark the machine and stop using it.
11	Red emergency shutdown button	Push the red emergency shutdown button inward to Off position to stop all functions and shut down the engine. Pull the red emergency shutdown button out to On position to operate the machine.
12	Enabling switch	Press the enabling switch to start up the drive function.
13	Proportional control handle of drive function	Press the enable switch and move the control handle in the direction indicated by the blue arrow on control panel, and then the machine will move in the direction indicated by the blue arrow. Press the enable switch and move the control handle in the direction indicated by the yellow arrow on control panel, and then the machine will move in the direction indicated by the yellow arrow.
14	Thumb rocker switch for turning function	Press the enable switch and press the left side of the thumb rocker, then the machine will turn to the left. Press the enable switch and press the right side of the thumb rocker, then the machine will turn to the right.
15	Wrist pad	
16	Enabling button of lifting function with indicator	Press this button to activate the lifting function.
17	Proportional switch for rising and falling of outrigger and platform (Hall switch)	When the automatic leveling button indicator is on, push the switch in the direction indicated by the yellow arrow, and then the outrigger will extend; push the switch in the direction indicated by the blue arrow, and then the outrigger will retract. When the enabling button indicator of single outrigger is on, push the switch in the direction indicated by the yellow arrow, and then the outrigger will extend; push the switch in the direction indicated by the blue arrow, and then the outrigger will retract. When the enabling button indicator with lifting function is on, push the switch forward, and then the platform will rise;



		push the rocker switch backward, and then the platform will lower.
--	--	--

### 5.2.2 PCU (If equipped)

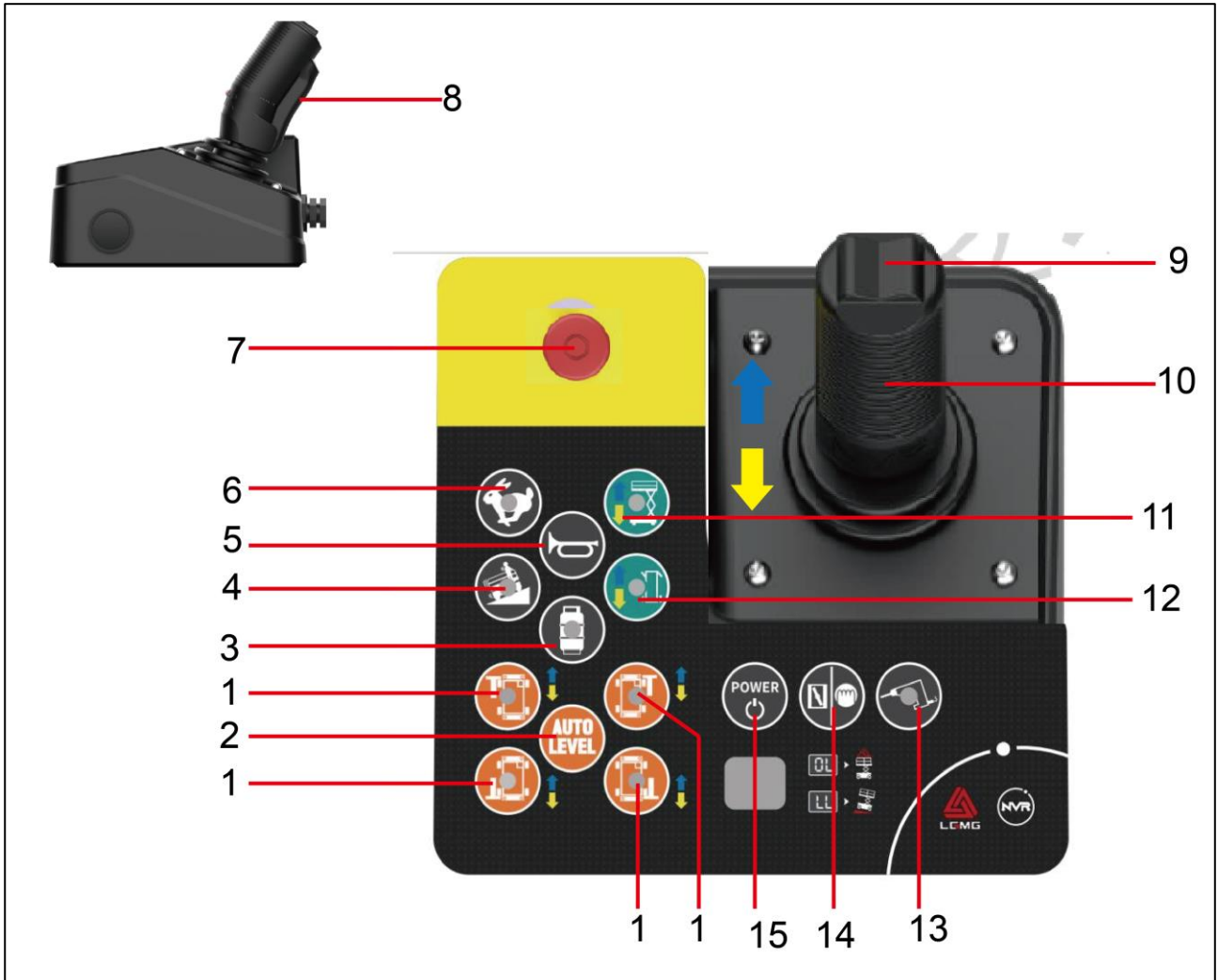

No.	Name	Operation function description
1	Functional enabling button of outrigger with indicator	Press and hold this button to activate the ascending/descending functions of single outrigger.
2	Automatic leveling button of outrigger	Press and hold this button to activate the automatic leveling function.
3	Gasoline/LPG model: LPG operating button with indicator	Press this button to select LPG.
4	Machine tilt button with indicator: Please operate it at a low speed during tilt.	Press this button to perform operation at a low speed during tilt.
5	Horn button	Press this button, and the horn will sound. Release this button, and the horn will stop sounding.
6	Idling selection button of engine with indicator	Press this button to select the idling setting of engine. The indicator is on,

		indicating that the high idling has been selected. The indicator is off, indicating that the intermediate and low idling has been selected.
7	Red emergency shutdown button	Push the red emergency shutdown button inward to Off position to stop all functions and shut down the engine. Pull the red emergency shutdown button out to On position to operate the machine.
8	Enabling switch	Press the enabling switch to start up the function.
9	Thumb rocker switch for steering function	Press the enable switch and press the left side of the thumb rocker, then the machine will turn to the left. Press the enable switch and press the right side of the thumb rocker, then the machine will turn to the right.
10	Proportional control handle of driving/lifting /Outrigger function	Press the driving function button, press the enable switch and move the control handle in the direction indicated by the blue arrow or yellow arrow on control panel, and then the machine will move in the direction indicated by the blue arrow or yellow arrow. Press the lifting function button, press the enable switch and move the control handle forward, and then the machine will lift; move the control handle backward, and then the machine will lower. Press and hold the outrigger function button, press the enable switch and move the control handle in the direction indicated by the yellow arrow or blue arrow on control panel, and then the outrigger will extend or retract.
11	Enabling button of lift function with indicator	Press this button to activate the lift function.
12	Enabling button of drive function with indicator	Press this button to activate the walking function.
13	Hydraulic generator(If equipped)	Press this button to turn the generator on. Press the button again to turn the generator off.
14	Glow plug button	Press this button to activate the glow plug.
15	Startup button of engine	Press this button to start up the engine.

## 5.3 Basic Operation

### Basic Operation Principle

- 1) The machine's electrical wiring and harnesses are complete, and form a complete circuit. The sensors work normally, the main power supply is connected, and the function of the key switch and emergency shutdown switch is normal.
- 2) Open the key switch, select the upper control unit or the lower control unit, and pull the upper and lower control units out upon emergency shutdown, and then the vehicle has no alarm and error code.
- 3) For normal operation of the machine, press and hold the enable switch and functional control, and move the control handle or switch to cause the desired operation of the machine.

### Ground Control Station Operation

- 1) Engine Startup or Shutdown
  - a) When the key switch is in the lower control mode, pull out the emergency shutdown switch. The lower control LCD will display System Ready.
  - b) Press the engine startup button, and release the button after about 3 seconds upon engine startup.
  - c) Press the emergency shutdown switch or turn the key switch back to the neutral position. The engine will shut down.

- 2) Platform Lift

Start the engine in lower control mode; press the button for lift. The platform will lift or lower depending upon the direction the switch is pressed.

- 3) Emergency Descent

When unable to lower the platform normally due to a fault, enable the emergency descending function. Simultaneously press the auxiliary function enabling button and the auxiliary descent button to lower the platform.

### Platform Control Station Operation

- 1) Engine Startup or Shutdown
  - a) Turn the key switch to the upper control mode, the lower control LCD will display System Ready.
  - b) Press the engine startup button, and release the button after about 3 seconds upon engine startup.
  - c) For shutdown of the engine, press the emergency shutdown switch, the engine will be shut down immediately.
- 2) Driving
  - a) After completion of system initialization and startup of engine, observe if there are any personnel or obstacles around. Press the horn button before driving, to alert personnel the machine will be driving.
  - b) Press the driving function button and enable button on the Platform Control Station, and push the drive handle forward or backward, and then the vehicle will drive forward or backward.
  - c) The vehicle will stop when the enable switch is released or the control handle is returned to the neutral position,.

- 3) Steering

Press the driving function button. Press the enable button on Platform Control Station and the thumb rocker switch to the left or right, the vehicle will turn to the left or right. Release the enabling switch or the steering switch to stop steering.

- 4) Lifting and Lowering

Turn the key switch to the upper control mode, start the engine, press the button with lift function, press the enable button and move the control handle. The platform will lift when the control handle move to the forward; and the platform will lower when the control handle move to the backward.

- 5) Outriggers

Turn the key switch to the upper control mode, start the engine, press and hold one of the four outrigger function enable buttons, press the

enable switch and move the control handle. The outrigger will extend and retract depending upon the direction the button was pushed. After the outrigger is firmly set, the indicator on the button will be on.

### 6) Automatic Leveling

When the machine is tilted, it is necessary to use outriggers to level the vehicle. The control system allows automatic leveling using the outriggers. Turn the key switch to the upper control mode, start the engine, press and hold the automatic leveling button, press the enable switch and move the control handle in the direction of yellow arrow or blue arrow, the outrigger will extend or retract. After leveling, the four lamps on outrigger button will be on; push the switch, there will be an alarm. At this moment, the outrigger cannot extend, indicating that the vehicle is in leveling mode.

**System fault diagnosis and fault code-SR18D/SR23D**

Display(GCU)		Display (PCU)	Description	Solution
First generation	Second generation			
01 Internal ECU Fault	0x01 Internal ECU Fault	0x01	Main control system Ground Control Station Error	Replace the Ground Control Station
02 Platform ECU Fault	0x02 Platform ECU Fault	0x02	Communication error	Check the wiring, and replace the upper and lower control units separately to determine the fault if the wiring is in a good condition
07 lockout_two	0x07 lockout_two	0x07	lockout_two	Unlock by the server
09 Search statues	0x09 Search statues	0x09	Search statues	Just remind the search statues, not fault
-	0x10 Pressure Compens Fault	0x10	Unipath voltage-type compensating-pressure sensor fault (occur in machines with two compensating-pressure sensors)	Check the wiring and Pressure sensor
12 Tilt alarm LL	0x0C Tilt alarm LL	0x0C	Tilt alarm LL	Move the machine to the level ground
14 Angle sensor fault	0x0E Angle sensor fault	0x0E	Angle sensor fault	Check the wiring and Angle sensor
15 Pressure sensor fault	0x0F Pressure sensor fault	0x0F	Pressure sensor fault	Check the wiring and Pressure sensor
20 Chassis Start Sw Fault	0x14 Chassis Start Sw Fault	0x14	Chassis start switch error while starting	Check the switch and the wiring
21 Chassis Choke Sw Fault	0x15 Chassis Choke Sw Fault	0x15	Shutdown switch opening error while starting	Check the switch and the wiring
22 Chassis Up Sw Fault	0x16 Chassis Up Sw Fault	0x16	Rising switch opening error while starting	Check the switch and the wiring
23 Chassis Lift Sw Fault	0x17 Chassis Lift Sw Fault	0x17	Hoisting switch opening error while starting	Check the switch and the wiring
24 Down Sw Fault	0x18 Down Sw Fault	0x18	Descending switch opening error while starting	Check the switch and the wiring
25 Left Turn Sw Fault	0x19 Left Turn Sw Fault	0x19	Platform left turn switch opening error while starting	Check the switch and replace the upper control unit
26 Right Turn Sw Fault	0x1A Right Turn Sw Fault	0x1A	Platform right turn switch opening error while starting	Check the switch and replace the upper control unit

Display(GCU)		Display (PCU)	Description	Solution
First generation	Second generation			
27 Drive Enable Sw Flt	0x1B Drive Enable Sw Flt	0x1B	Platform enabling switch opening error while starting	Check the switch and replace the upper control unit
28 Off Neutral Drive Joystick	0x1C Off Neutral Drive Joystick	0x1C	No platform handle in the middle position while starting	Check the handle and replace the upper control unit
29 Platform lift Sw Fault	0x1D Platform lift Sw Fault	0x1D	Lifting function key opening error	Check the handle and replace the upper control unit
30 Off Neutral lift Joystick	0x1E Off Neutral lift Joystick	0x1E	Center lifting operating handle closing	Check the handle and replace the upper control unit
31 Platform Choke Sw Fault	0x1F Platform Choke Sw Fault	0x1F	Shutdown switch opening error while starting	Check the switch and replace the upper control unit
32 Platform Start Sw Fault	0x20 Platform Start Sw Fault	0x20	Platform ignition switch opening error while starting	Check the switch and replace the upper control unit
33 Left Front Outrig Sw Flt	0x21 Left Front Outrig Sw Flt	0x21	Outrigger left front switch opening error while starting	Check the switch and replace the upper control unit
34 Right Front Outrig Sw Flt	0x22 Right Front Outrig Sw Flt	0x22	Outrigger right front switch opening error while starting	Check the switch and replace the upper control unit
35 Left Rear Outrig Sw Flt	0x23 Left Rear Outrig Sw Flt	0x23	Outrigger left rear switch opening error while starting	Check the switch and replace the upper control unit
36 Right Rear Outrig Sw Flt	0x24 Right Rear Outrig Sw Flt	0x24	Outrigger right rear switch opening error while starting	Check the switch and replace the upper control unit
37 Auto Level Switch Fault	0x25 Auto Level Switch Fault	0x25	Automatic level switch opening error while starting	Check the switch and replace the upper control unit
38 Platform Walk Sw Fault	0x26 Platform Walk Sw Fault	0x26	The button of walking on the PCU activated while the machine power on.	Check the button if necessary replace the PCU
40 LOST_COMM_GPS	0x28 LOST_COMM_GPS	0x28	Disconnect the communication between GCU and	Check the wire between GCU and GPS

Display(GCU)		Display (PCU)	Description	Solution
First generation	Second generation			
			GPS	
41 LOCKOUT_ON E	0x29 LOCKOUT_ONE	0x29	Lockout- primary level	Unlock the machine by the server
42 DOWNLIMIT DOWNLIMIT Fault	0x2A DOWNLIMIT DOWNLIMIT Fault	0x2A	Lower limit switch failure, lower limit switch trigger position and angle sensor detection height Inconsistent	Check the lower limit switch, check the angle sensor, or recalibrate the height
43 9m limit fault	0x2B 9m limit fault	0x2B	9m limit switch failure, 9m limit switch trigger position and angle sensor detect high Degree of inconsistency	Check 9m limit switch, check angle sensor, or recalibrate altitude
44 Down limit SW Open Fault	0x2C Down limit SW Open Fault	0x2C	Down limit SW Open Fault	Check the down limit SW open connection
45 Down limit SW Close Fault	0x2D Down limit SW Close Fault	0x2D	Down limit SW Close Fault	Check the down limit SW close connection
46 9M Limit SW Open Fault	0x2E 9M Limit SW Open Fault	0x2E	9M Limit SW Open Fault	Check the 9m limit SW open connection
47 9m limit sw close fault	0x2F 9m limit sw close fault	0x2F	9m limit sw close fault	Check the 9m limit SW close connection
52 Func Prop Coil Fault	0x34 Func Prop Coil Fault	0x34	Parallel valve coil fault	Check the circuit and replace the solenoid valve
54 Up Coil Fault	0x36 Up Coil Fault	0x36	Rising valve coil fault	Check the circuit and replace the solenoid valve
55 Down Coil Fault	0x37 Down Coil Fault	0x37	Falling valve coil fault	Check the circuit and replace the solenoid valve
56 Right Turn Coil Fault	0x38 Right Turn Coil Fault	0x38	Right-turn coil fault	Check the circuit and replace the solenoid valve
57 Left Turn Coil Fault	0x39 Left Turn Coil Fault	0x39	Left-turn coil fault	Check the circuit and replace the solenoid valve
58 Brake Coil Fault	0x3A Brake Coil Fault	0x3A	Brake coil fault	Check the circuit and replace the solenoid valve
66 Low Oil Pressure	0x42 Low Oil Pressure	0x42	Low oil pressure fault	Check the circuit and replace the pressure sensor
67 High Coolant Temperature	0x43 High Coolant	0x43	High oil temperature	Check the circuit and replace the temperature

Display(GCU)		Display (PCU)	Description	Solution
First generation	Second generation			
	Temperature		fault	sensor
68 Low ECU Voltage	0x44 Low ECU Voltage	0x44	Low voltage fault	Check the circuit and battery, and replace the battery
69 Low Engine Rpm	0x45 Low Engine Rpm	0x45	Engine underspeed fault	Check the circuit and engine
70 High Engine RPM	0x46 High Engine RPM	0x46	Engine overspeed fault	Check the circuit and engine
71 RF Limit SW Close Fault	0x47 RF Limit SW Close Fault	0x47	RF Limit SW Close Fault	Check the harness and travel switch
72 RF Limit SW Open Fault	0x48 RF Limit SW Open Fault	0x48	RF Limit SW Open Fault	Check the harness and travel switch
73 RR Limit SW Close Fault	0x49 RR Limit SW Close Fault	0x49	RR Limit SW Close Fault	Check the harness and travel switch
74 RR Limit SW Open Fault	0x4A RR Limit SW Open Fault	0x4A	RR Limit SW Open Fault	Check the harness and travel switch
75 LF Limit SW Close Fault	0x4B LF Limit SW Close Fault	0x4B	LF Limit SW Close Fault	Check the harness and travel switch
76 LF Limit SW Open Fault	0x4C LF Limit SW Open Fault	0x4C	LF Limit SW Open Fault	Check the harness and travel switch
77 LR Limit SW Close Fault	0x4D LR Limit SW Close Fault	0x4D	LR Limit SW Close Fault	Check the harness and travel switch
78 LR Limit SW Open Fault	0x4E LR Limit SW Open Fault	0x4E	LR Limit SW Open Fault	Check the harness and travel switch
80 Left Front Otrg Coil Flt	0x50 Left Front Otrg Coil Flt	0x50	Left front outrigger solenoid valve coil fault	Check the circuit and replace the solenoid valve
81 Left Rear Otrg Coil Flt	0x51 Left Rear Otrg Coil Flt	0x51	Left rear outrigger solenoid valve coil fault	Check the circuit and replace the solenoid valve
82 Right Front Otrg Coil Flt	0x52 Right Front Otrg Coil Flt	0x52	Right front outrigger solenoid valve fault	Check the circuit and replace the solenoid valve
83 Right Rear Otrg Coil Flt	0x53 Right Rear Otrg Coil Flt	0x53	Right rear outrigger solenoid valve fault	Check the circuit and replace the solenoid valve
84 Outrigger Ext Coil Flt	0x54 Outrigger Ext Coil Flt	0x54	Outrigger extension solenoid valve fault	Check the circuit and replace the solenoid valve
85 Outrigger Ret Coil Flt	0x55 Outrigger Ret Coil Flt	0x55	Outrigger retraction solenoid valve fault	Check the circuit and replace the solenoid valve
87 DPF Fault	0x57 DPF Fault	0x57	Alarming--DPF3 level	Operate DPF of the engine



Display(GCU)		Display (PCU)	Description	Solution
First generation	Second generation			
Lv3	Lv3 Regeneration Needed			
88 DPF Fault Lv4	0x58 DPF Fault Lv4 Regeneration Needed	0x58	Alarming--DPF4 level	Operate DPF of the engine
89 DPF Fault Lv5	0x59 DPF Fault Lv5 Regeneration Needed	0x59	Alarming--DPF5 level	Operate DPF of the engine
90 2 Speed Coil Fault	0x5A 2 Speed Coil Fault	0x5A	2 Speed coil error	Check the circuit and replace the solenoid valve
91 Bypass Coil Fault	0x5B Bypass Coil Fault	0x5B	Shunt coil fault	Check the circuit and replace the solenoid valve
92 Drive Fwd Prop Coil Fault	0x5C Drive Fwd Prop Coil Fault	0x5C	Drive forward proportional coil error	Check the circuit and replace the solenoid valve
93 Drive Rev Prop Coil Fault	0x5D Drive Rev Prop Coil Fault	0x5D	Drive backward proportional coil error	Check the circuit and replace the solenoid valve
94 Machine Type Fault	0x5E Machine Type Fault	0x5E	Model error	Reselect the correct model
95 Low Fuel	0x5F Low Fuel	0x5F	Low Fuel	Check the fuel level and add the fuel
96 FreeWheel Coil Fault	0x60 FreeWheel Coil Fault	0x60	Coil fault	Check the wire, replace the solenoid valve
97 ACCUM Coil Fault	0x61 ACCUM Coil Fault	0x61	Coil fault	Check the wire, replace the solenoid valve
98 HBY Coil Fault	0x62 HBY Coil Fault	0x62	Coil fault	Check the wire, replace the solenoid valve
99 Platform Overload Fault	0x63 Platform Overload Fault	0x63	Platform Overload Fault	Check the circuit and overload the platform
0X64 DPF Fault Lv6	0X64 DPF Fault Lv6 Regeneration Needed	0X64	Alarming--DPF6 level	Operate DPF of the engine
101 Engine Fault	0x65 Engine Fault	0x65	Engine Fault	Check engine maintenance manual,Conduct fault trouble shooting according to SPN
102 BPSCDNP	0x66 BPSCDNP	0x66	Fault of engine air inlet pressure sensor	Check the connector, sensor and the engine maintenance manual.
103 APP2SRC	0x67 APP2SRC	0x67	Engine throttle pedal fault	Check the engine connector or sensor

Display(GCU)		Display (PCU)	Description	Solution
First generation	Second generation			
104 OPSCD	0x68 OPSCD	0x68	Fault of the engine oil pressure	Check the connector, sensor and the engine maintenance manual.
105 BPSCD	0x69 BPSCD	0x69	Engine air intake pressure sensor fault	Check the engine connector or sensor
106 IATSCDSRC	0x6A IATSCDSRC	0x6A	Engine air intake temperature sensor fault	Check the engine connector or sensor
107 CTSCD	0x6B CTSCD	0x6B	water temperature sensor fault	Check the engine connector or sensor
108 RAILCDOFSTST	0x6C RAILCDOFSTST	0x6C	Rail pressure sensor failure	Check the engine connector or sensor
109 BATTCDSRC	0x6D BATTCDSRC	0x6D	Battery voltage fault	Check the engine connector or sensor
110 OTSCD	0x6E OTSCD	0x6E	Oil temperature sensor fault	Check the engine connector or sensor
111 INJINI	0x6F INJINI	0x6F	INJdriverIC initialization version number error	Check the engine connector or sensor
112 MSSCD	0x70 MSSCD	0x70	Multi-state switch signal failure	Check the engine connector or sensor
113 TECUSRC	0x71 TECUSRC	0x71	ECU temperature sensor failure	Check the engine connector or sensor
114 INVLCYL1	0x72 INVLCYL1	0x72	Injector 1 malfunction	Check the engine connector or sensor
115 NVLCYL2	0x73 NVLCYL2	0x73	Injector 2 failure	Check the engine connector or sensor
116 INJVLVCYL3	0x74 INJVLVCYL3	0x74	Injector 3 failure	Check the engine connector or sensor
117 INVLCYL4	0x75 INVLCYL4	0x75	Injector 4 malfunction	Check the engine connector or sensor
118 MEUNCD	0x76 MEUNCD	0x76	Fuel gauge failure	Check the engine connector or sensor
119 ENGSPD	0x77 ENGSPD	0x77	Engine speed signal failure	Check the engine connector or sensor
120 FANCDSP	0x78 FANCDSP	0x78	Cooling fan speed failure	Check the engine connector or sensor
121 STRTCDLSSC	0x79 STRTCDLSSC	0x79	Starter motor relay failure	Check the engine connector or sensor

Display(GCU)		Display (PCU)	Description	Solution
First generation	Second generation			
122 ENGPRTOVRS PD	0x7A ENGPRTOVRSP D	0x7A	Engine speed overspeed	Check the engine connector or sensor
123 HWEMONEEP RO M	0x7B HWEMONEEPRO M	0x7B	EEPROM read error	Check the engine connector or sensor
124 AIRHT	0x7C AIRHT	0x7C	Intake heating normally open failure	Check the engine connector or sensor
125 ENGMCAS	0x7D ENGMCAS	0x7D	Missing camshaft signal	Check the engine connector or sensor
126 ENGMCRS	0x7E ENGMCRS	0x7E	Missing crankshaft signal	Check the engine connector or sensor
127 COMT5OST	0x7F COMT5OST	0x7F	dec1 message t50 signal Receive error	Check the engine connector or sensor
128 GEARDETERR	0x80 GEARDETERR	0x80	The idle sleep switch does not work properly when the ecu powered on	Check the engine connector or sensor
129 ECBTCPLAUS	0x81 ECBTCPLAUS	0x81	Start / stop button stuck under car	Check the engine connector or sensor
130 FRMMNGTRF1	0x82 FRMMNGTRF1	0x82	can receive trf1 data amount error	Check the engine connector or sensor
131 COMGPSDRV	0x83 COMGPSDRV	0x83	t15 The time when the engine speed is 0 without powering off exceeds a certain value	Check the engine connector or sensor
132 RAILME	0x84 RAILME	0x84	The amount of fuel in the fuel gauge exceeds the threshold	Check the engine connector or sensor
133 NETMNGCANA	0x85 NETMNGCANA	0x85	Can communication error	Check the engine connector or sensor
134FRMMNGE BCI	0x86 FRMMNGEBCI	0x86	can receive frame ebc1 data length error	Check the engine connector or sensor
135 FRMMNGEBC2	0x87 FRMMNGEBC2	0x87	Data length error	Check the engine connector or sensor
136 MNGENGTEM P2	0x88 MNGENGTEMP2	0x88	CAN receive EngTemp2 data volume error	Check the engine connector or sensor

Display(GCU)		Display (PCU)	Description	Solution
First generation	Second generation			
137 FRMMNGERCIDR	0x89 FRMMNGERCIDR	0x89	can receive frame etc1dr data volume error	Check the engine connector or sensor
138 FRMMNGETC1	0x8A FRMMNGETC1	0x8A	etc1 message data length error	Check the engine connector or sensor
139 FRMMNGETC2	0x8B FRMMNGETC2	0x8B	Can receive frame etc2 data amount error	Check the engine connector or sensor
140 FRMMNGRXC CVS	0x8C FRMMNGRXC CVS	0x8C	RxCCVS message data length error	Check the engine connector or sensor
141 FRMMNGTCO1	0x8D FRMMNGTCO1	0x8D	can receive frame tco1 message length error	Check the engine connector or sensor
142 FRMMNGTSC1AE	0x8E FRMMNGTSC1AE	0x8E	can receive frame tsc1ae Data volume error	Check the engine connector or sensor
143 FRMMNGTSC1AR	0x8F FRMMNGTSC1AR	0x8F	can receive frame tsc1ar Data volume error	Check the engine connector or sensor
144 FRMMNGTSC1DE	0x90 FRMMNGTSC1DE	0x90	can receive frame tsc1de data volume error	Check the engine connector or sensor
145 RMMNGTSC1DR	0x91 RMMNGTSC1DR	0x91	can receive frame tsc1dr Data volume error	Check the engine connector or sensor
146 FRMMNGTSC1PE	0x92 FRMMNGTSC1PE	0x92	cantotsc1pe data Volume error	Check the engine connector or sensor
147 FRMMNGTSC1TE	0x93 FRMMNGTSC1TE	0x93	cantotsc1te data Volume error	Check the engine connector or sensor
148 FRMMNGTSC1TR	0x94 FRMMNGTSC1TR	0x94	cantotsc1tr data Volume error	Check the engine connector or sensor
149 FRMMNGTSC1VE	0x95 FRMMNGTSC1VE	0x95	cantotsc1ve data Volume error	Check the engine connector or sensor
150 FRMMNGTSC1VR	0x96 FRMMNGTSC1VR	0x96	Cantotsc1vr data Wrong quantity	Check the engine connector or sensor
151 FRMMNGHRV	0x97 FRMMNGHRVD	0x97	Can receives frame HRVD Wrong data	Check the engine connector

Display(GCU)		Display (PCU)	Description	Solution
First generation	Second generation			
D			volume	or sensor
152 FRMMNGDAS HDSP	0x98 FRMMNGDASHD SP	0x98	CAN receives frame DashDspl data error	Check the engine connector or sensor
153 FRMMNGEGF1	0x99 FRMMNGEGF1	0x99	Can receives frame EGF1 data error.	Check the engine connector or sensor
154 FRMMNGCMID LC	0x9A FRMMNGCMIDL C	0x9A	Can receives frame CM1 data error	Check the engine connector or sensor
155 FRMMNGDEC 1	0x9B FRMMNGDEC1	0x9B	Can receives frame DEC1data error	Check the engine connector or sensor
156 FRMMNGETC7	0x9C FRMMNGETC7	0x9C	Can receives frame etc7 data error	Check the engine connector or sensor
157 FRMMNGAPP	0x9D FRMMNGAPP	0x9D	Bus to receive throttle signal overrun	Check the engine connector or sensor
158 FRMMNGREM APP	0x9E FRMMNGREMAP P	0x9E	Bus to receive remote throttle signal overrun	Check the engine connector or sensor
159 COMGPS	0x9F COMGPS	0x9F	DEC1 message T50 signal Receiving error	Check the engine connector or sensor
160 Gener Fault	0xA0 Gener Fault	0xA0	Generator Malfunction	Check the generator or generator connectors
161 BATTVLTGER R	0xA1 BATTVLTGERR	0xA1	High battery voltage	Check the engine connector or sensor
162ENGOVER HEAT	0xA2 ENGOVERHEAT	0xA2	Overheat of the engine	Check the engine connector or sensor
163 WATERTEMPH IGH	0xA3 WATERTEMPHIG H	0xA3	Coolant temp too high	Check the connector, sensor and the engine maintenance manual.
164 WATERTEMPL OW	0xA4 WATERTEMPLO W	0xA4	Coolant temp too low	Check the connector, sensor and the engine maintenance manual.
165 BATVOL_HIGH	0xA5 BATVOL_HIGH	0xA5	High voltage of the battery	Check the connector, sensor and the engine maintenance manual.
166 ENGOVERRU N	0xA6 ENGOVERRUN	0xA6	Engine over the running speed	Check the connector, sensor and the engine maintenance manual.
167	0xA7	0xA7	Low voltage of the	Check the connector,

Display(GCU)		Display (PCU)	Description	Solution
First generation	Second generation			
SENVOLT_LO W	SENVOLT_LOW		sensor	sensor and the engine maintenance manual.
168 ACTUATORFA ULT	0xA8 ACTUATORFAUL T	0xA8	Fault of the actuator	Check the connector, sensor and the engine maintenance manual.
169 SPEEDSENFA ULT	0xA9 SPEEDSENFAUL T	0xA9	RPM sensor fault	Check the connector, sensor and the engine maintenance manual.

## **Chapter 6 Pre-Operation Check**





## 6.1 No Operation Except Following Cases

You have understood and practiced the principles about safe operation of the machine in this manual.

- 1) Avoid dangerous situations.
- 2) Always perform a pre-operation inspection.
- 3) Check the work place.
- 4) Always perform a pre-use functional test.
- 5) Use the machine only for its intended purpose.

## 6.2 Basic Principles

- 1) The operator is responsible for checks before operation and routine maintenance.
- 2) The check before operation is an intuitive check process performed by the operator prior to each shift. The purpose of the check is to find out if there is an obvious problem with the machine before the operator performs a functional test.
- 3) The check before operation is also used to determine if routine maintenance procedures are required. The operator is only allowed to perform routine maintenance items as specified in this manual.
- 4) Please refer to the list on the next page and check for changes, damage, loose or missing parts for each item and location.
- 5) A damaged or modified machine shall not be used. If damages or any unauthorized changes are found, the machine shall be tagged out and not operated.
- 6) Only qualified repair technicians can repair machines as required by the manufacturer. After repair, the operator must perform check before operation again before performing the functional test.
- 7) Regular repair and check shall be performed by qualified repair technicians in accordance with the manufacturer's specifications and the requirements listed in the responsibility manual.

## 6.3 Check Before Operation

- 1) Ensure the manual is complete, legible and stored in the document box on the platform.
- 2) Ensure all decals are clear, legible and properly positioned. See the decal section.
- 3) Check engine oil leakage and oil level appropriateness. See the "Repair" section.
- 4) Check for hydraulic oil leakage and proper oil level. Fill as needed. See the "Repair" section.
- 5) Check for engine coolant leakage and proper coolant level. Add coolant as needed. See the "Repair" section.
- 6) Check for battery leakage and proper electrolyte level. Add distilled water as needed. See the "Repair" section
- 7) Check the following components or areas for damage, improper installation or missing parts and unauthorized changes:
  - Electrical components, harnesses and cables
  - Hydraulic hoses, connectors, valve blocks and hydraulic cylinders
  - Fuel and hydraulic tanks
  - Wear pads
  - Tires and wheels
  - Engine and related components
  - Limit switches, alarms and horns
  - Nuts, bolts and other fasteners
  - Platform extension components
  - Platform entrance door
  - Indicators and alarms
  - Safety arm
  - Pins and fasteners
  - Platform control handle
  - Outrigger cover and foot pad
  - Check the entire machine for:
    - Cracks in welds or structural components
    - Indentation or damage to the machine

- Ensure that all structural components and other key components are complete and all relevant fasteners and pins are in the correct position and tightened.
- Ensure that the guardrail has been installed, and guardrail bolts have been properly installed and tightened.



**Note: If the platform must be**

**raised to check the machine, ensure the safety arm is in the correct position. See the "Operation Instructions" section.**

## **Chapter 7 Workplace Check**



## 7.1 No Operation Is Allowed Unless

You have known and practiced the rules for safe operation of machine in the Operation Manual.

- 1) Avoid dangerous situations.
- 2) Always perform a pre-operation inspection.
- 3) Check the workplace. You should understand pre-operation inspection before proceeding with the next step.
- 4) Always perform a pre-use functional test.
- 5) Use the vehicle only for its intended purpose.

## 7.2 Basic Principles

- 1) Workplace inspection will help the operator determine if the workplace is safe for operation of the vehicle. The operator should perform pre-operation inspection before moving the vehicle to the workplace.
- 2) It is the operator's responsibility to understand and remember the hazards in the workplace and to be aware of and avoid these hazards when moving, installing and operating the vehicle.

## 7.3 Workplace Inspection

Beware and avoid the following dangerous situations

- 1) Steep slope or holes
- 2) Protrusions, ground obstacles or debris
- 3) Uneven surface
- 4) Unstable or smooth surface
- 5) Overhead obstacles and high voltage wires
- 6) Dangerous location
- 7) Surface support that is not sufficient to withstand the full load applied by the vehicle
- 8) Wind and weather conditions
- 9) Unauthorized personnel
- 10) Other possible unsafe conditions



## **Chapter 8 Functional Test**





## 8.1 No Operation Is Allowed Unless

You have understood and practiced the principles about safe operation of the vehicle in this manual.

- 1) Avoid dangerous situations.
- 2) Always perform a pre-operation inspection.
- 3) Check the workplace.
- 4) Always perform a pre-use functional test.
- 5) You should understand the functional test and inspection before proceeding with the next step.
- 6) Use the vehicle only for its intended purpose.

## 8.2 Basic Principles

- 1) Functional tests are used to detect faults before operating the vehicle.
- 2) The operator must follow the steps to test all the functions of the vehicle.
- 3) Do not use a malfunctioning vehicle. If a fault is found, the vehicle must be marked and stopped.
- 4) Only qualified authorized service technicians are allowed to maintain the vehicle according to the manufacturer's instructions.
- 5) After maintenance is completed, the operator must perform the pre-operation inspection and functional test again before operating the vehicle.

## 8.3 Functional Test

- 1) Choose a test place that is solid, level and free of obstacles.

## 8.4 Test on the Ground Control Station

- 1) Pull the red emergency shutdown button on the platform and ground out to the "On" position.
- 2) Turn the key switch to the Ground Control Station.

Result: The LCD screen will light up and show SYSTEM READY.

Note: LCD reading display needs to be preheated before display under cold weather conditions.

- 3) Start the engine.

### Emergency Shutdown Test

- 1) Push the red emergency shutdown button on the ground inwards to the "Off" position.

Result: The engine will be shut down without running any function.

- 2) Pull the red emergency shutdown button out to the "On" position and restart the engine.

### Lifting/Lowering Functions Test

The audible alarm on the machine and the standard horn is from the same alarm. The horn makes a continuous sound. The lowering alarm sounds 60 times per minute. The alarm sounds 180 times per minute when the machine is tilted.

- 1) Do not press the lowering and lifting start button. Press and hold the platform lifting button.

Result: The platform shall not lift.

- 2) Press and hold the enabling button with lifting functions. Press and hold the platform lifting button.

Result: The platform shall lift.

- 3) Press and hold the enabling button with lifting functions. Press and hold the platform lowering button.

Result: The platform shall lower. When the platform lowers, the lowering alarm shall sound.

### Emergency Descent Function Test

- 1) Press and hold enabling button with lifting functions while raising the platform by about 0.6m.
- 2) Push the red emergency shutdown button on the ground inwards to the off position and turn off the engine.
- 3) Pull the red emergency shutdown button out to the on position.
- 4) Press and hold the emergency descent

enabling button. Press and hold the platform emergency lowering button.

Result: The platform shall lower.

- 5) Turn the key switch to the Platform Control Station and restart the engine.

## 8.5 Platform Control Station Test

### Emergency Shutdown Test

- 1) Push the red emergency shutdown button on the platform to the "Off" position.

Result: The engine shall be turned off and all functions shall be disabled.

- 2) Pull the red emergency shutdown button out to the "On" position.

Result: The indicator will be green.

### Horn Test

- 1) Press the horn button.
- 2) Result: The horn will sound.

### Lifting/Lowering Functions and Function Enabling Test

- 1) Start the engine.
- 2) Press the enable switch and push the lifting/lowering control handle forward.

Result: The platform shall not lift.

- 3) Press the enabling button with lifting functions.
- 4) Press the enable switch and push the lifting/lowering control handle forward.

Result: The platform shall lift.

- 5) Press the enabling button with lifting functions.
- 6) Press the enable switch and push the lifting/lowering control handle backward.

Result: The platform shall lower. When the platform lowers, the lowering alarm shall sound.

### Steering Test



**Notice: When performing steering and driving function tests, stand in the**

**middle of the platform and face the steering end of the machine.**

- 1) Press the driving function button.
- 2) Press and hold the enabling switch on the control handle.
- 3) Press the thumb rocker switch at the top of the control handle in the direction indicated by the blue triangle on the control panel.

Result: The steering wheels shall turn in the direction indicated by the blue triangle on the control panel.

- 4) Press the thumb rocker switch in the direction indicated by the yellow triangle on the control panel.

Result: The steering wheel shall turn in the direction indicated by the yellow triangle on the control panel.

### Drive and Brake Functions Test

- 1) Press the driving function button.
- 2) Press and hold the enabling switch on the control handle.
- 3) Move the control handle slowly until the machine starts to move in the direction indicated by the blue arrow on the control panel and return the handle to the center position.

Result: The machine shall move in the direction indicated by the blue arrow on the control panel and then stop suddenly.

- 4) Press and hold the enabling switch on the control handle.
- 5) Move the control handle slowly until the machine starts to move in the direction indicated by the yellow arrow on the control panel and return the handle to the center position.

Result: The machine shall move in the direction indicated by the yellow arrow on the control panel and then stop suddenly.



**Notice: On any slope the machine can climb, the brakes must be able to hold the machine stationary.**

### Reduced Driving Speed Test

- 1) Raise the platform.
- 2) Press and hold the enabling switch on the control handle.
- 3) Slowly move the control handle up to the full driving position.

Result: When the platform is raised, the maximum driving speed of SR1023D/SR1323D/SR1623D shall not exceed 1.1Km/h.

When the platform is raised, the maximum driving speed of SR0818D/SR1018D/SR1218D shall not exceed 0.5Km/h.

If the maximum driving speed exceeds 1.1Km/h (SR1023D/SR1323D/SR1623D)/ 0.5Km/h (SR0818D/SR1018D/SR1218D) when the platform is raised, please tag out the machine immediately and stop operating it.

### 8.6 Tilt Sensor Operation Test



**Notice: The test is performed from the ground with a remote Platform Control Station. Do not stand inside the platform.**

- 1) Lower the platform completely.
- 2) Drive two wheels on one side to an obstacle or curb with height of 0.18m/0.59ft.
- 3) Raise the platform to a height which is about 3.6m off of the ground.

Result: The platform is stopped and the tilt alarm sounds 180 times per minute. The indicator of enabling button of lifting function will be in red.

- 4) Move the drive control handle in the direction indicated by the blue arrow, and move it to the direction indicated by the yellow arrow.

Result: The drive function shall not work in either direction.

- 5) Lower the platform and drive the machine away from the obstacle.

### 8.7 Upper Limit Switch and Outriggers (If Equipped) Test

- 1) Press and hold the enabling button with lifting functions. Raise the platform.

Result: The platform of SR1323D/SR1623D shall be raised to 8.5m and then stopped. The platform shall not be raised more than 8.5m unless the outrigger has been extend.

- 2) Lower the platform.
- 3) Press and hold the automatic leveling button.
- 4) Move the control handle to the backward direction.

Result: The outrigger shall be stretched out to level the machine. When the machine is level, it will sound.

- 5) Raise the platform.

Result: The platform shall be raised to the highest point.

- 6) Lower the platform.



## **Chapter 9 Operation Instructions**



## 9.1 No Operation is Allowed Unless

You have understood and practiced the principles about safe operation of the vehicle in this manual.

- 1) Avoid dangerous situations.
- 2) Always perform a pre-operation inspection.
- 3) Check the workplace.
- 4) Always perform a pre-use functional test.
- 5) Use the vehicle only for its intended purpose.

## 9.2 Basic Principles

- 1) The machine is a rough terrain hydraulic lift equipped with work platform on a scissors mechanism. Vibration produced by the operation of machine has no danger to the operator on the work platform. The machine can carry staff and portable tools to the place in a certain height from the ground, or to the working area on the machine or equipment.
- 2) The Operating Instructions section provides specific instructions for all aspects of vehicle operation. It is the operator's responsibility to follow all safety rules and instructions in this manual.
- 3) This machine is designed for lifting workers and tools to the overhead workplace, it is unsafe or even dangerous to use the vehicle for other purposes.

 **Notice: This machine is strictly prohibited from carrying loads.**

- 4) Only trained and authorized personnel can operate the vehicle. If more than one operator uses the same vehicle at different times during the same work shift, they must be qualified operators and follow all safety rules and instructions in the Operation and Maintenance Manual. This means that every new operator should perform pre-operation inspections, functional tests and workplace inspections before operating

the machine.

## 9.3 Emergency Stop

- 1) On the Ground Control Station or Platform Control Station, push the red emergency stop button to "Off" position to close all functions and shut down the engine.
- 2) If there is any functions operating after pushing the red emergency shutdown button, repair the function.

## 9.4 Engine startup

- 1) On the Ground Control Station, turn the key switch to the needed position.
- 2) Make sure that the ground and platform red emergency stop buttons are pulled out to "On" position.
- 3) Press the engine startup button.

 **Notice: Before starting the engine at 10°C and lower temperatures, press and hold the glow plug for 5 to 10 seconds. The continuous use of the glow plug is limited to 20 seconds.**

 **Notice: SR1023D/SR1323D/**

**SR1623D engine (DEUTZ D2.9L4 /Kubota V2403-CR-E5) can be automatically preheated at low temperatures. The engine can be preheated only when the whole vehicle is powered on.**

If the primary startup time is no more than 5 - 10 seconds (continuous working time of starter motor shall be no more than 15 seconds), and if it fails to be started and needs to be started again, the interval shall be more than 1 minute. If it fails to be started for three times, identify the reason and repair the fault. Wait for 60 seconds before attempting to start it again.

Before operation, the engine shall be idled for 5 minutes to ensure it sufficiently lubricated in case of hydraulic system damage.

At extremely low temperatures of  $-18^{\circ}\text{C}$  and lower, the machine must be equipped with a low-temperature starter kit option. If the engine is started at the temperature lower than  $-18^{\circ}\text{C}$ , it may need to use a booster battery.

## 9.5 Operation from Ground

- 1) Turn the key switch to the Ground Control Station.
- 2) The ground and platform red emergency stop buttons are pulled out to "On" position.
- 3) Start the engine.

### Adjustment of Platform Position

- 1) Press and hold the enabling button for lifting functions.
- 2) Press and hold the lifting or lowering button.
- 3) The drive and turning function cannot be operated from the Ground Control Station.

### Idling Selection of Engine

Press the idling selection button to select the engine idling (rpm). Provide two idling settings of engine.

The indicator is off: low idling.

The indicator is on: high idling.

## 9.6 Operation from Platform

- 1) Turn the key switch to the Platform Control Station.
- 2) The ground and platform red emergency stop buttons are pulled out to "On" position.
- 3) Start the engine.

### Adjustment of Platform Position

- 1) Press the enabling button of lifting function.
- 2) Press the enable switch and push the lifting/lowering control handle in needed direction. The platform will raise when the control handle is moved to the forward, or lower when the control handle is moved to the backward.

### Steering

- 1) Press the driving function button.

- 2) Press and hold the enabling switch on the control handle.
- 3) Turn the steering wheels using the thumb rocker switch on the top of control handle.

### Drive

- 1) Press the driving function button.
- 2) Press and hold the enabling switch on the control handle.
- 3) Acceleration: Move the control handle slowly away from the center position.
- 4) Deceleration: Move the control handle slowly toward the center position.
- 5) Stop: Return the control handle to the center position or release the function enabling switch.
- 6) Use the direction arrow on the Platform Control Station and platform to verify the direction the machine is to be moved.
- 7) The machine drive speed is limited when the platform is elevated.

### Drive Selection Switch

Symbols of machine on the slope: Please operate it within low speed scope when it is tilted.

### The Indicator is in Red

If the indicator is in red, please press and pull out the red emergency stop button to reset the system.

If the lamp is still red, tag out the machine and stop operating it.

## 9.7 Drive on Slope

Determine rated value and grade of slope and side slope of the machine. The rated value of slope is applicable to the folding machine.



SR0818D(With outrigger)/SR1018D/SR1218D :

 <p>Maximum rated value of slope in folding position.</p>	<p>35% (19.3 °)</p>
---	---------------------



 <p>Maximum rated value of side slope in folding state.</p>	<p>35% (19.3 °)</p>
--	---------------------

SR0818D(Without outrigger)/SR1023D  
SR1323D/SR1623D:

 <p>Maximum rated value of slope in folding position.</p>	<p>40% (22 °)</p>
 <p>Maximum rated value of side slope in folding state.</p>	<p>40% (22 °)</p>

 **Notice: Rated value of slope is**

**limited by the ground conditions and traction.**

- 1) Determination of grade: Measure the slope with a digital inclinometer or follow the steps below.
- 2) Tools required: Carpenter’s ruler, straight block with a length of at least 1m, tape measure.
- 3) Place the block on the slope.
- 4) Place the carpentry’s ruler on the upper edge of the block at the end of the downhill slope and raise the end of the block until it is level.

Keep the block level and measure the vertical distance from the bottom of the block to the ground.

Divide the tape measure distance (the raised height) by the block length (travel) and multiply by 100.

Example:

Wood block = 11.8ft

Travel = 11.8ft

Raised height = 0.98ft

$0.98/11.8=8.3\%$  rating

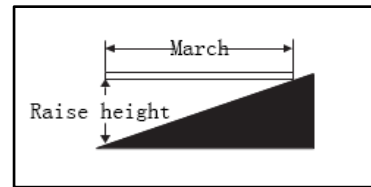

- 5) If the slope exceeds the maximum uphill, downhill or side slope rating, the vehicle must be lifted or transported up and down the slope. See the Transportation and Lifting section for further instructions on transporting the machine.

## 9.8 Platform Extension and Retraction

- 1) Raise the extension lock handle of the platform to the upper limit position (about 80 °) of handle.
- 2) Push the extension lock handle of the platform to extend the platform to the required position.
- 3) Do not stand on the extension platform when extending the platform.
- 4) Press the extension lock handle of the platform to make the upper and lower truss plate engage with each other, to lock the extension platform.

## 9.9 Emergency Descent

- 1) When unable to lower the platform normally due to a fault, enable the emergency descending function. Simultaneously press the auxiliary function enabling button and the auxiliary descent button to lower the platform.

## 9.10 Using Platform Control Station to Operate on the Ground

- 1) Maintain a safe distance among operator, machine and stationary objects.
- 2) Pay attention to the forward direction of machine when using the control station.

## 9.11 Outrigger Operation

- 1) Put the machine in an accepted operation

area.

**Notice: The engine must be running to operate the outriggers.**

- 2) Press and hold the automatic leveling button.
- 3) Press the enable switch and push the lifting/lowering control handle in the direction of yellow arrow. Outriggers will be extended to level the machine. The machine will give a warning tone when it is level.
- 4) If only one outrigger is extend, the indicator for the enabling button of lifting function will be in red. All drive and lifting functions are forbidden.
- 5) When all outriggers contact the ground securely, the indicators of the enabling buttons for the lifting functions and the single outrigger button will be in green.
- 6) The drive function is forbidden when the outrigger is extended.

**Control of Single Outrigger**

- 1) Press and hold one or more outrigger buttons.
- 2) Press the enable switch and push the lifting/lowering control handle for the outrigger to level the machine according to the desired direction.

**9.12 Safety Arm Use**

- 1) Raise the platform to a height which is about 3.2m/10.5ft away off of the ground.
- 2) Lift the safety arm and move it to the middle of scissors axle sleeve, rotate it upward until it is vertical.
- 3) Lower the platform height until the safety arm contacts the axle sleeve completely.

**9.13 Auxiliary Descent**

**(If equipped)**

When unable to lower the platform normally due to a fault, pull the cable assembly that is located at the rear of the machine outward.

Result: The platform will lower.

**9.14 Fall Protection**

- 1) Personal falling protection equipment (PFPE) is not required during machine operation. If PFPE is required in the workplace or user rules, obey the following regulations:
- 2) All PFPE must comply with corresponding government regulations and must be subject to check and use in accordance with the manufacturer's instructions.

**9.15 DPF Regeneration**

DPF is a closed system for filtering soot particulate emissions.

Automatic regeneration: the vehicle will automatically enable regeneration function during operation.

Manual regeneration: when the DPF alarm indicator of the lower control box is on, and the vehicle has no engine /system failure & alarm, the machine can be manually regenerated at the stowed state.

Park the machine in a safe and reliable position. Before performing the manual regeneration operation, run the engine at idle speed for several minutes to ensure that the engine water temperature has exceeded 50°C.

Operation Instruction:

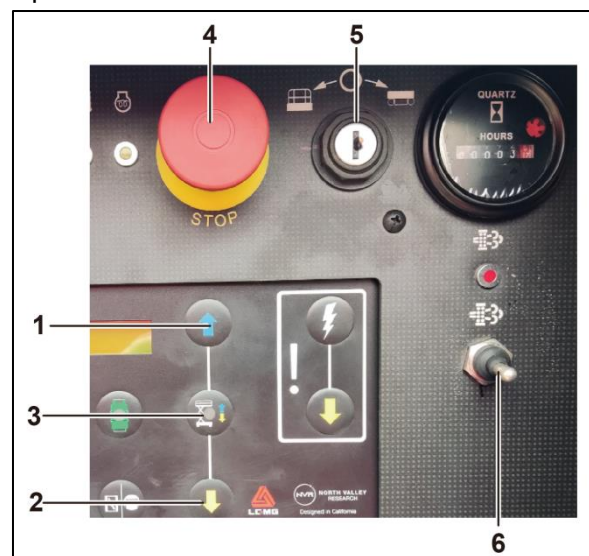

1. Shut down the machine, pull the emergency stop button (4) to the "ON" position, press and hold the button (1) and (2) at the same time, then turn the key button (5) to the right to

operation position of ground control.

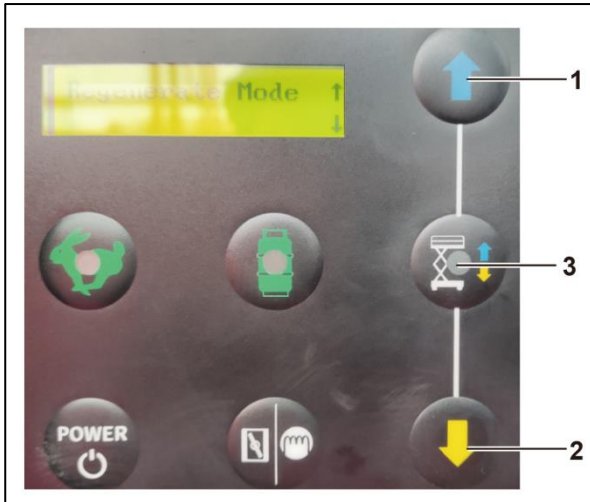

2. Press the button (1) or (2), set to "Regenerate Mode", then press OK button (3).



3. Operate machine with the prompts:

- 1) Start the engine.
- 2) Press the OK button (3).

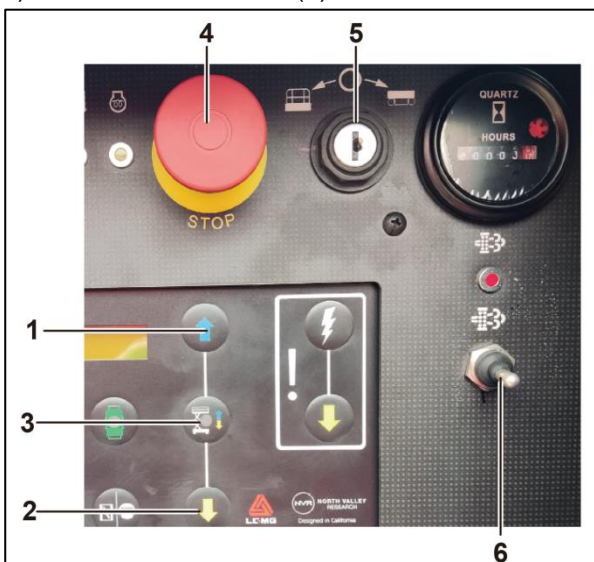

4. When the regenerating condition was allowed, then push the regenerate button (6).



5. Start the "Regenerate Mode".

**⚠ Notice: During manual DPF**

**regeneration, the exhaust gas becomes hotter than usual and its quantity increases. Check to see if there is nothing flammable around and the place is well ventilated.**

**⚠ Notice: On DPF-equipped**

**engines, part of the fuel may get mixed with engine oil during the regenerating process. This may dilute the oil and increase its quantity. If the oil rises above the oil level gauge upper limit, it means the oil has been diluted too much, resulting in a trouble. In such case, immediately change the oil for new one.**

**If the interval of DPF regeneration becomes 5 hours or less, be sure to change the oil for new one.**

**Note: Be sure to inspect the engine, locating it on a level place. If placed on gradients accurately, oil quantity may not be measured.**

**⚠ Notice:**

If the machine have DPF cleaning alarm system.

- Clean the DPF in case of an alarm or every 6000 DPF operating hours whichever comes earlier.
- DPF cleaning interval is depending on engine operating conditions.

If the machine does not have DPF cleaning alarm system, clean the DPF every 3000 operating hours.

### 9.16 Low temperature start kit (If Equipped)

 Risk of scalding: It is prohibited to touch the heated heaters.

 Risk of fire: It is prohibited to place inflammables and explosives around the heaters.

 Risk of electric shock: It is prohibited to wash the heaters directly with water. It is only allowed to connect the heater power line to a grounded AC three-wire outlet with a leakage protector.

The low temperature start kit is prohibited to use, when the ambient temperature is above 0°C.

The low temperature start kit aims to start the machine normally and have it run smoothly at low temperature through heating of related devices by the externally powered heaters installed on the engine, battery and hydraulic oil tank.

Connection example:

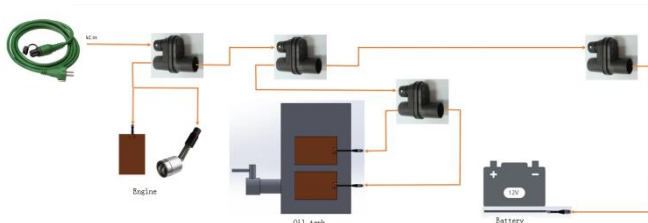

Recommended heating duration:

Model	Ambient temperature	Ambient temperature
-------	---------------------	---------------------

	above -20°C	below -20°C
SR18D	<2 hours	2h< heating duration <4h
SR23D	<2 hours	2h< heating time <4h

### 9.17 After Each Use

- 1) Select a safe parking position, which must be solid horizontal ground without an obstacle and avoid places with busy transportation.
- 2) Lower the platform.
- 3) Turn the key switch to the "Off" position and remove the key to avoid unauthorized use.
- 4) Lock the wheels.

## **Chapter 10 Transportation and Lifting Instructions**



## 10.1 Compliance

- 1) When the machine is lifted by a crane or forklift, keep normal judgment and planning to control the movement of machine.
- 2) Only personnel with high-altitude lifting qualifications can load and unload the machine.
- 3) The transport vehicle must be parked on a level surface.
- 4) When loading the vehicle, the transport vehicle must be fixed to prevent movement.
- 5) Make sure the transport vehicle's capacity, loading surface, chains or belts are sufficient to withstand the weight of the vehicle. Refer to the nameplate for the weight of the vehicle.
- 6) Before releasing the brakes, the machine must be on level ground or have been secured in place.
- 7) Do not drive the vehicle on a slope that exceeds the vehicle's uphill, downhill or slope rating. Refer to "Drive on the Slope" in the "Operation Instructions" section.
- 8) If the slope of the transport vehicle exceeds the maximum slope rating, the winch must be used to load and unload the vehicle as specified.
- 9) Prevent the plug from falling from the guardrail when it is taken off. Grasp the guardrail firmly when folding it.

## 10.2 Securing on Trucks or Trailers During Transportation

- 1) Always lock the wheels of the platform when preparing for transportation.
- 2) Secure the machine on the transport surface using the fastening positions on the chassis.
- 3) Use at least 4 chains or belts. Ensure each chain or belt has sufficient load strength.
- 4) Turn the key switch to the "Off" position and remove the key before transportation.

## 10.3 Ensuring Transportation Safety

- 1) Always lock the platform wheels when preparing for transportation.

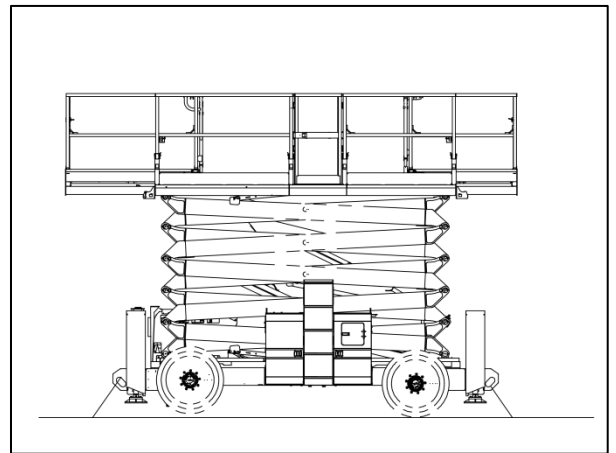
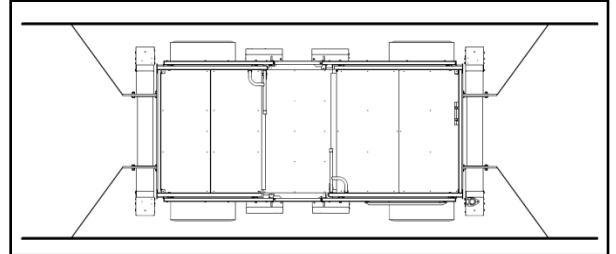

- 2) Retract and secure the extension platform.
- 3) Before transportation, turn the key switch to the "Off" position and remove the key.
- 4) Thoroughly check the machine for any loose or unsecured components.
- 5) Secure the machine on the transport surface using the fastening positions on the chassis.
- 6) Use at least 4 chains or belts.
- 7) Ensure each chain or belt used has sufficient load strength.
- 8) If the railing has been folded, use a belt to secure it before transportation.

### Compliance

- 1) Only qualified rigging personnel are allowed to assemble slings and lift the platform.
- 2) Make sure that the crane's lifting capacity, loading surface, belt or rope is sufficient to withstand the weight of the vehicle. Refer to the decal and nameplate for the weight of

the vehicle.

## 10.4 Lifting guidance

- 1) Lower the platform completely. Ensure that the extension platform, control unit and chassis tray are safely and reliably secured. Remove all loose components from the platform.
- 2) Only connect the lifting sling to the specified lifting point of the platform.
- 3) Adjust the lifting sling to avoid damaging the platform and keep the platform to be horizontal.

- 3) Make sure that the winch cable is properly secured to the fastening point of the drive chassis and that there are no obstacles in the moving direction.
- 4) Reverse the above procedures to reengage the brakes.

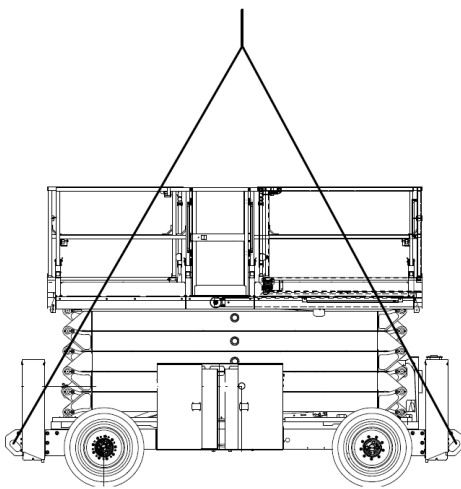

## 10.5 Freewheel configuration for trailers

- 1) Wedge the wheel to prevent the vehicle from moving.

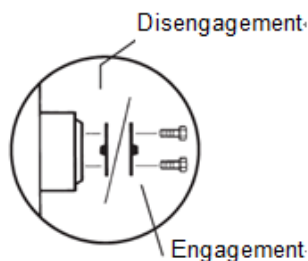

Figure 10-1 Brake release

- 2) Turn over all driving wheel hub separating covers to release wheel brakes, as shown in Figure 10-1.



