

MODELS | SJ 6826RT SJ 6832RT



Operating Manual

Rough Terrain Compact Series (CE)

129952AF-A September 2010



Skyjack Service Center 3451 Swenson Ave. St. Charles, Illinois, 60174 USA

Phone: 630-262-0005

Toll Free: 1-800-275-9522

Fax: 630-262-0006

Email: service@skyjack.com

Parts (North America)

Toll Free: 1-800-965-4626

Toll Free Fax: 1-888-782-4825

Email: parts@skyjack.com

Parts & Service (Europe) Unit 1 Maes Y Clawdd, Maesbury Road Industrial Estate

Oswestry, Shropshire SY10 8NN UK

Phone: +44-1691-676-235

Fax: +44-1691-676-238

Email: info@skyjackeurope.co.uk

Skyjack Asia Pacific

Singapore

Phone: +65-6449-3710

Fax: +65-6449-7690

Email: skyjack@singnet.com.sg

The Safety Alert Symbol identifies important safety messages on aerial platform, safety signs in manuals or elsewhere. When you see this symbol, be alert to the possibility of personal injury or death. Follow the instructions in the safety message.



This Safety Alert Symbol means attention!

Become alert! Your safety is involved.



DANGER

DANGER indicates an imminently hazardous situation which, if not avoided, will result in death or serious injury.



WARNING

WARNING indicates a potentially hazardous situation which, if not avoided, could result in death or serious injury.



CAUTION

CAUTION indicates a potentially hazardous situation which, if not avoided, may result in minor or moderate injury. It may also be used to alert against unsafe practices.

IMPORTANT

IMPORTANT indicates a procedure essential for safe operation and which, if not followed, may result in a malfunction or damage to the aerial platform.

Table of Contents

Section 1 - About Your Aerial Platform

Read and Heed

Aerial Platform Definition.....	7
Purpose of Equipment.....	7
Use of Equipment.....	7
Manual.....	7
Operator.....	7
Service Policy and Warranty.....	7
Optional Accessories.....	7
Scope of this Manual.....	7

Safety Rules

Operator Safety Reminders.....	8
Electrocution Hazard.....	8
Safety Precautions.....	9

Section 2 - Operation

2.1	General.....	13
2.1-1	Operator Qualifications.....	13
2.1-2	Operator's Responsibility for Maintenance.....	13
2.1-3	Maintenance and Inspection Schedule.....	13
2.1-4	Owner's Inspections.....	13
2.2	Major Components.....	14
2.3	Major Assemblies.....	15
2.3-1	Base.....	15
2.3-2	Lifting Mechanism.....	15
2.3-3	Platform.....	15
2.4	Serial Number Nameplate.....	15
2.5	Component Identification.....	16
2.5-1	Main Power Disconnect Switch.....	16
2.5-2	Motion Alarm.....	16
2.5-3	Tilt Alarm.....	16
2.5-4	Load Sensing System.....	16
2.5-5	Brake System.....	17
2.5-6	Emergency Lowering System.....	17
2.5-7	Lowering Warning System.....	17
2.5-8	Free-wheeling Valve.....	17
2.5-9	Base Control Console.....	18
2.5-10	Maintenance Support.....	19
2.5-11	Manual Storage Box.....	19
2.5-12	Platform Control Console.....	20
2.5-13	Folding Guardrail System.....	21
2.5-14	Safety Belt/Harness Attachment Bar.....	21
2.6	Component Identification (Special Options).....	22
2.6-1	Outrigger/Generator Control Console (Auto-leveling) (If Equipped).....	22
2.6-2	800W AC Inverter (If Equipped).....	22
2.7	Operator's Responsibility.....	23
2.8	Visual and Daily Maintenance Inspections.....	24
2.9	Function Tests.....	33

Table of Contents

Section 2 - Operation (Continued)

2.10	Start Operation	39
2.10-1	To Activate Base Control Console	40
2.10-2	To Raise or Lower Platform Using Base Control Console.....	40
2.10-3	To Activate Platform Control Console	41
2.10-4	To Raise or Lower Platform Using Platform Control Console	41
2.10-5	To Drive Forward or Backward	42
2.10-6	To Steer	42
2.10-7	To Select Drive Torque	43
2.10-8	To Extend or Retract Manual Extension Platform	43
2.10-9	Hydraulic Outriggers (If Equipped)	44
2.10-10	Generator (If Equipped)	45
2.10-11	Electrical Inverter (If Equipped)	45
2.10-12	Shutdown Procedure	45
2.11	Refueling Procedure.....	46
2.11-1	Regular Fuel.....	46
2.11-2	Propane.....	47
2.12	Loading/Unloading.....	48
2.12-1	Lifting.....	48
2.12-2	Driving	49
2.13	Guardrail Folding Procedure.....	50
2.14	Moving the Aerial Platform through a Doorway.....	52
2.15	Winching and Towing Procedure	54
2.15-1	To Release the Free-wheeling Valve	54
2.15-2	To Release the Brakes Manually.....	55
2.16	Emergency Lowering Procedure	56
2.17	Maintenance Support Procedure.....	57
2.18	Labels	67

List of Tables

Table 2.1	Standard and Optional Features	59
Table 2.2	Specifications and Features.....	60
Table 2.3	Owner's Annual Inspection Record	61
Table 2.4	Maximum Platform Capacities	61
Table 2.5	Floor Loading Pressure.....	62
Table 2.6	EC Declaration of Conformity	64
Table 2.7	Maintenance and Inspection Schedule	65
Table 2.8	Operator's Checklist	66

SKYJACK is continuously improving and expanding product features on its equipment, therefore, specifications and dimensions are subject to change without notice.

Aerial Platform Definition

A mobile device that has an adjustable position platform supported from ground level by a structure.

Purpose of Equipment

The SKYJACK Rough Terrain Compact Series aerial platform is designed to transport and raise personnel, tools and materials to overhead work areas.

Use of Equipment

The aerial platform is a highly maneuverable, mobile work station. Lifting and driving must be on a flat, level, compacted surface. It can be driven over uneven terrain only when the platform is fully lowered.

Manual

The operating manual is considered a fundamental part of the aerial platform. It is a very important way to communicate necessary safety information to users and operators. A complete and legible copy of this manual must be kept in the provided weather-resistant storage compartment on the aerial platform at all times.

Operator

The operator must read and completely understand both this operating manual and the safety panel label located on the platform and all other warnings in this manual and on the aerial platform. Compare the labels on the aerial platform with the labels found within this manual. If any labels are damaged or missing, replace them immediately.

Service Policy and Warranty

SKYJACK warrants each new SJRT Compact Series aerial platform to be free of defective parts and workmanship for the first 24 months. Any defective part will be replaced or repaired by your local SKYJACK dealer at no charge for parts or labor. Contact the SKYJACK Service Department for warranty statement extensions or exclusions.

Optional Accessories

The SKYJACK aerial platform is designed to accept a variety of optional accessories. These are listed under “Standard and Optional Features” in [Table 2.1](#). Operating instructions for these options (if equipped) are located in [Section 2](#) of this manual.

For non-standard components or systems, contact the SKYJACK Service Department at

☎ : 44-1691-676-235

📠 : 44-1691-676-239

Include the model and serial number for each applicable aerial platform.

Scope of this Manual

- a. This manual applies to the CE version of the SJRT Compact Series aerial platform models listed on [Table 2.1](#).
 - Equipment identified with “CE” meets the requirements for the European countries, i.e., Machinery Directive 98/37/EC, 89/392/EEC and EMC Directive 89/336/EEC and the corresponding EN standards.
- b. Operators are required to conform to national, state or territorial/provincial and local health and safety regulations applicable to the operation of this aerial platform.



WARNING

Failure to comply with your required responsibilities in the use and operation of the aerial platform could result in death or serious injury!

Operator Safety Reminders

A study conducted by St. Paul Travelers showed that most accidents are caused by the failure of the operator to follow simple and fundamental safety rules and precautions.

You, as a careful operator, are the best insurance against an accident. Therefore, proper usage of this aerial platform is mandatory. The following pages of this manual should be read and understood completely before operating the aerial platform.

Common sense dictates the use of protective clothing when working on or near machinery. Use appropriate safety devices to protect your eyes, ears, hands, feet and body.

Any modifications from the original design are strictly forbidden without written permission from SKYJACK.

Electrocution Hazard

This aerial platform is not electrically insulated. Maintain a Minimum Safe Approach Distance (MSAD) from energized power lines and parts as listed below. The operator **must allow** for the platform to sway, rock or sag. **This aerial platform does not provide protection from contact with or proximity to an electrically charged conductor.**

**DO NOT USE THE AERIAL PLATFORM AS A GROUND FOR WELDING.
DO NOT OPERATE THE AERIAL PLATFORM DURING LIGHTNING OR STORMS.**



DANGER

Avoid Power Lines

Minimum Safe Approach Distance

CE Guidance Note

“Avoidance of danger from overhead lines”

Adhere strictly to the governmental rulings and regulations applicable in your country.

FAILURE TO AVOID THIS HAZARD WILL RESULT IN DEATH OR SERIOUS INJURY!

Safety Precautions

Know and understand the safety precautions before going on to next section.



WARNING

Failure to heed the following safety precautions could result in tip over, falling, crushing, or other hazards leading to death or serious injury.

- **KNOW** all national, state/provincial and local rules which apply to your aerial platform and jobsite.
- **TURN** main power disconnect switch “○” off when leaving the aerial platform unattended. Remove the key to prevent unauthorized use of the aerial platform.
- **WEAR** all the protective clothing and personal safety devices issued to you or called for by job conditions.

- **DO NOT** wear loose clothing, dangling neckties, scarves, rings, wristwatches or other jewelry while operating this lift.

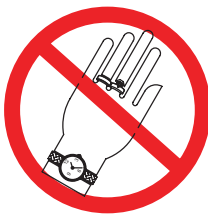

- **AVOID** entanglement with ropes, cords or hoses.



- **AVOID** falling. Stay within the boundaries of the guardrails.



- **DO NOT** raise the aerial platform in windy or gusty conditions.



- **DO NOT** increase the lateral surface area of the platform. Increasing the area exposed to the wind will decrease aerial platform stability.



- **DO NOT** drive or elevate the aerial platform if it is not on a firm level surface. Do not drive elevated near depressions or holes of any type, loading docks, debris, drop-offs and surfaces that may affect the stability of the aerial platform.



- **If operation in areas with holes or drop-offs is absolutely necessary**, elevated driving shall not be allowed. Position the aerial platform horizontally only with the platform fully lowered. After ensuring that all 4 wheels or outriggers (if equipped) have contact with level firm surface, the aerial platform can be elevated. After elevation, the drive function must not be activated.



- **Elevated driving** must only be done on a firm level surface.



- **DO NOT** ascend or descend a grade when elevated. When fully lowered, ascending or descending, only grades up to rated maximum listed in [Table 2-2](#) are permissible.



Safety Precautions (Continued)

Know and understand the safety precautions before going on to next section.

- **DO NOT** operate on surfaces not capable of holding the weight of the aerial platform including the rated load, e.g., covers, drains, and trenches.



- **DO NOT** operate an aerial platform that has ladders, scaffolding or other devices mounted on it to increase its size or work height. It is prohibited.



- **DO NOT** exert side forces on aerial platform while elevated.



- **DO NOT** use the aerial platform as a crane. It is prohibited.



- **DO NOT** sit, stand or climb on the guardrails. It is prohibited.



- **DO NOT** climb on scissor arm assembly. It is prohibited.

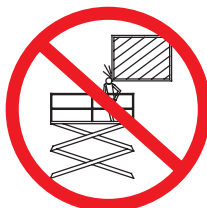

- **BE AWARE** of overhead obstructions or other possible hazards around the aerial platform when driving or lifting.

- **DO NOT** raise the aerial platform while the aerial platform is on a truck, fork lift or other device or vehicle.



- **BE AWARE** of crushing hazards. Keep all body parts inside platform guardrail.



- **DO NOT** lower the platform unless the area below is clear of personnel and obstructions.



- **ENSURE** that there are no personnel or obstructions in the path of travel, including blind spots.

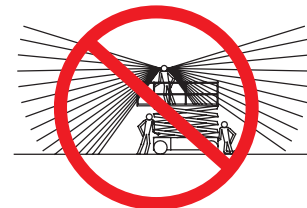

- **BE AWARE** of blind spots when operating the aerial platform.

- **STUNT** driving and horseplay are prohibited.

- **ENSURE ALL** tires are in good condition and lug nuts are properly tightened.

- **DO NOT** alter or disable limit switches or other safety devices.

- **DO NOT** use the aerial platform without guardrails, locking pins and the entry gate/chain/bar in place.

Safety Precautions (Continued)

Know and understand the safety precautions before going on to next section.

- **DO NOT** exceed the rated capacity of the aerial platform. Do make sure the load is evenly distributed on the platform.
- **DO NOT** attempt to free a snagged platform with lower controls until personnel are removed from the platform.
- **DO NOT** position the aerial platform against another object to steady the platform.
- **DO NOT** place materials on the guardrails or materials that exceed the confines of the guardrails unless approved by Skyjack.



WARNING

Entering and exiting the aerial platform should only be done using the three points of contact.

- Use only equipped access openings.
- Enter and exit only when the aerial platform is in the fully retracted position.
- Do use three points of contact to enter and exit the platform. Enter and exit the platform from the ground only. Face the aerial platform when entering or exiting the platform.
- Three points of contact means that two hands and one foot or one hand and two feet are in contact with the aerial platform or the ground at all times during entering and exiting.



WARNING

An operator should not use any aerial platform that:

- does not appear to be working properly.
- has been damaged or appears to have worn or missing parts.
- has alterations or modifications not approved by the manufacturer.
- has safety devices which have been altered or disabled.
- has been tagged or blocked out for non-use or repair.

Failure to avoid these hazards could result in death or serious injury.

Jobsite Inspection

- Do not use in hazardous locations.
- Perform a thorough jobsite inspection prior to operating the aerial platform, to identify potential hazards in your work area.
- Be aware of moving equipment in the area. Take appropriate actions to avoid collision.

2.0 Operation

This section provides the necessary information needed to operate the aerial platform. It is important that the user reads and understands this section before operating the aerial platform.

2.1 General

In order for this aerial platform to be in good working condition, it is important that the operator meets the necessary qualifications and follow the maintenance and inspection schedule referred to in this section.

2.1-1 Operator Qualifications

- Only trained and authorized personnel shall be permitted to operate an aerial platform.
- Safe use of this aerial platform requires the operator to understand the limitations and warnings, operating procedures and operator's responsibility for maintenance. Accordingly, the operator must understand and be familiar with this operating manual, its warnings and instructions, and all warnings and instructions on the aerial platform.
- The operator must be familiar with employer's work rules and related government regulations and be able to demonstrate the ability to understand and operate this make and model of aerial platform in the presence of a qualified person.

2.1-2 Operator's Responsibility for Maintenance



WARNING

Maintenance must be performed by trained and competent personnel who are familiar with mechanical procedures.

Death or serious injury could result from the use of an aerial platform that is not properly maintained or kept in good working condition.

- The operator must be sure that the aerial platform has been properly maintained and inspected before using it.
- The operator must perform all the daily inspections and function tests found in [Table 2.7](#), even if the operator is not directly responsible for the maintenance of this aerial platform.

2.1-3 Maintenance and Inspection Schedule

- The inspection points covered in [Table 2.7](#) indicate the areas of the aerial platform to be maintained or inspected and at what intervals the maintenance and inspections are to be performed.
- The actual operating environment of the aerial platform may affect the maintenance schedule.



WARNING

Use original or manufacturer-approved parts and components for the aerial platform.

2.1-4 Owner's Inspections

It is the responsibility of the owner to arrange daily, quarterly (or 150 hours) and annual inspections of the aerial platform. Refer to [Table 2.7](#) for recommended maintenance and inspection areas and intervals. A record of annual inspection is kept on a label located on the scissor assembly. Refer to [Table 2.3](#) in this manual.

2.2 Major Components

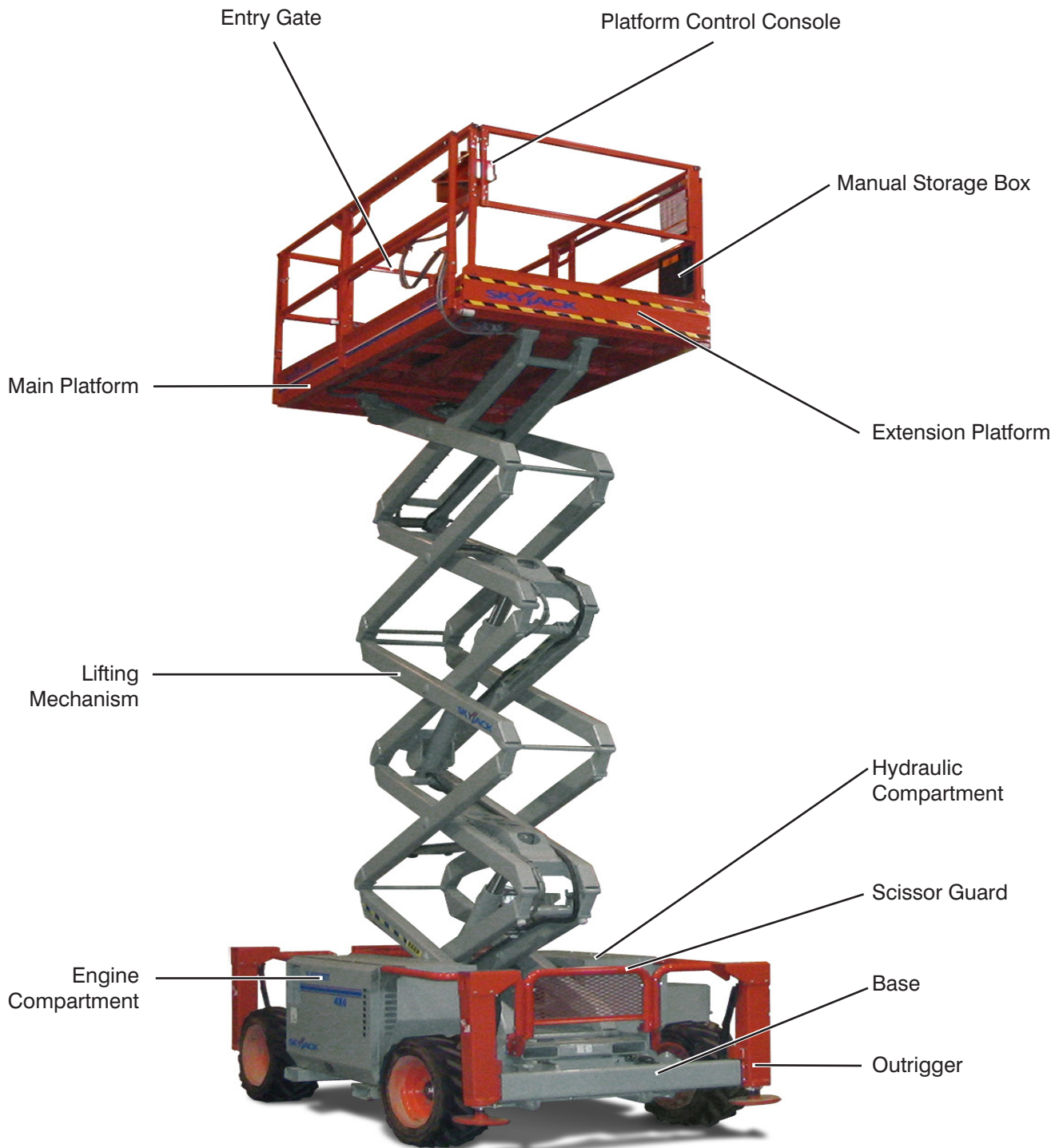

SKYJACK Model SJ 6826RT Aerial Platform

2.3 Major Assemblies

The aerial platform consists of three major assemblies: base, lifting mechanism and platform.

2.3-1 Base

The base is a rigid, one-piece weldment which supports two side compartments.

- One compartment contains the engine, 12V battery, base control console and electrical components. The other compartment contains the emergency lowering system, brake release and hydraulic components as well as fuel and hydraulic tanks.
- The propane cylinders (if equipped) are located on both sides of the hydraulic/fuel compartment.
- The four wheels are hydraulically-motor driven with two front wheels steerable by a hydraulic cylinder.
- The rear wheel motors have spring-applied hydraulically released disc brakes.

2.3-2 Lifting Mechanism

The lifting mechanism is constructed of formed steel or tube sections making up a scissor-type assembly. The scissor assembly is raised and lowered by single-acting hydraulic lift cylinders with holding valves. A two-section pump, driven by an engine, provides hydraulic power to the lift cylinders.

2.3-3 Platform

The platform is constructed of a tubular support frame, a skid-resistant “diamond plate” deck surface and 990 mm hinged guardrails with 152 mm toe boards and mid-rails. The platform can be entered from the rear through a spring returned gate with latch. The platform is also equipped with a manual extension platform. A 220V outlet is also located on the platform.

2.4 Serial Number Nameplate

The serial number nameplate, located at the rear of the aerial platform, lists the following:

- Model number
- Serial number
- Aerial platform weight
- Maximum drivable height
- Maximum capacities
- Maximum number of persons permissible on the platform
- Voltage
- System pressure
- Lift pressure
- Maximum platform height
- Maximum wheel load
- Date manufactured
- Maximum wind speed
- Maximum manual force
- Maximum incline
- Gradeability

2.5 Component Identification

The following descriptions are for identification, explanation and locating purposes only.

2.5-1 Main Power Disconnect Switch

This switch is located at the left side of the engine compartment.

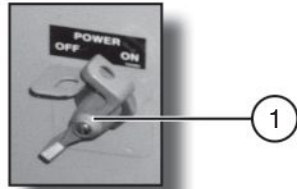

Figure 2-1. Main Power Disconnect Switch

1. **Main Power Disconnect Switch** - This switch, when in “○” off position, disconnects power to all circuits. Switch must be in “|” on position to operate any circuit. Turn switch “○” off when transporting aerial platform.

2.5-2 Motion Alarm

The alarm produces an audible sound when any control function is selected. On aerial platforms with certain options, a flashing amber light will accompany this alarm.

2.5-3 Tilt Alarm

The aerial platform is equipped with a device which senses when the aerial platform is out of level in any direction. When activated, it disables drive and lift functions of the aerial platform and an alarm produces an audible sound accompanied by the amber light. If the alarm sounds, lower the platform completely, then reposition aerial platform so that it is level before raising the platform.

NOTE

If the tilt alarm sounds and the platform does not, or only partially raises, immediately lower the platform completely and ensure that the aerial platform is on a firm level surface.

2.5-4 Load Sensing System

This system is a safety device that prevents any normal movement of the aerial platform from a stationary working condition after the rated load is reached and exceeded. Refer to [Table 2.4](#) for maximum platform capacities.

- **When 90% of the rated load is reached:**
The red power indicator light on the platform control console flashes.
- **When the rated load is reached:**
An audible alarm sounds for approximately 2 seconds, 5 times per minute.
- **When the rated load is exceeded:**
The flashing light and audible alarm continue and all electrically controlled aerial platform movement functions stop. To resume normal operation, remove the overload from the platform.
- **If the aerial platform during the operation comes in contact with an overhead obstruction:**
The platform could become overloaded and all functions would stop. Release of the platform from this situation can only be effected by use of the emergency lowering system. Refer to [Section 2.16](#).

NOTE

After reaching full extension and upon lowering, the aerial platform could stop and take an overload reading. Return the proportional controller to the neutral center position, and release the enable trigger switch. If the aerial platform is overloaded, the flashing light and audible alarm continue and all electrically controlled aerial platform movement functions stop. To resume normal operation, remove the overload from the platform.

2.5-5 Brake System

The brake system is located on the main manifold in the hydraulic/fuel compartment. The brakes must be manually disengaged before pushing, winching or towing. Refer to [Section 2.15-2](#) for procedure on how to release the brakes manually. The system contains the following controls:

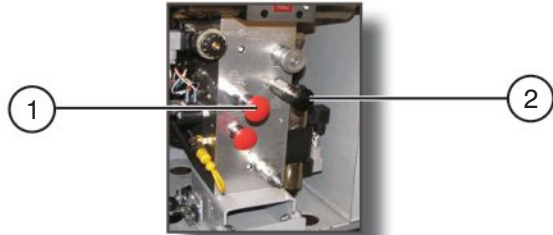

Figure 2-2. Brake System

1. Brake hand pump
2. Brake auto reset valve plunger

2.5-6 Emergency Lowering System

The emergency lowering system allows platform lowering in the event of an emergency or an electrical system failure. Refer to [Section 2.16](#) for the emergency lowering procedure. The system contains the following controls:

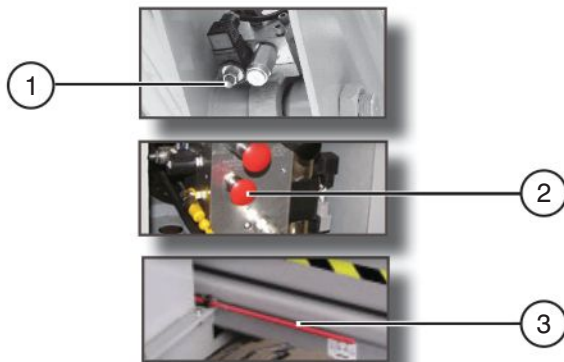

Figure 2-3. Emergency Lowering System

1. **Holding Valve Manual Override Knob** - Located on the holding valve at the bottom of each lift cylinder.
2. **Emergency Lowering Valve** - Located at the hydraulic/fuel compartment.
3. **Emergency Lowering Access Rod** - Located at the right side of the base.

2.5-7 Lowering Warning System

A lowering warning system automatically stops the lowering function before reaching the fully retracted position and sounds the alarm.

2.5-8 Free-wheeling Valve

Figure 2-4. Free-wheeling Valve

1. **Free-wheeling Valve** - The free-wheeling valve is located on the main manifold in the hydraulic/fuel compartment. Refer to [Section 2.15-1](#) for procedure on how to release the free-wheeling valve.

2.5-9 Base Control Console

The control console is located on the left side of the engine compartment. It contains the following controls:

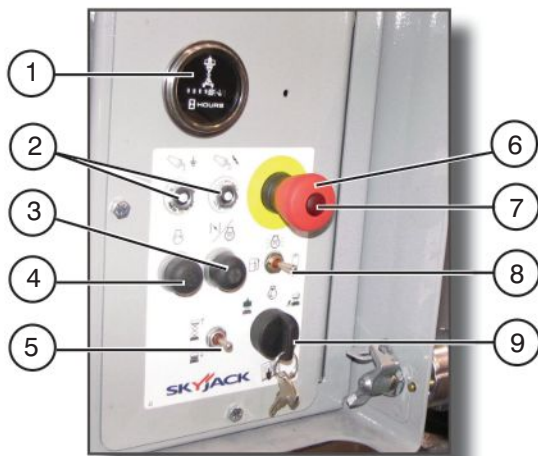

Figure 2-5. Base Control Console - Dual Fuel

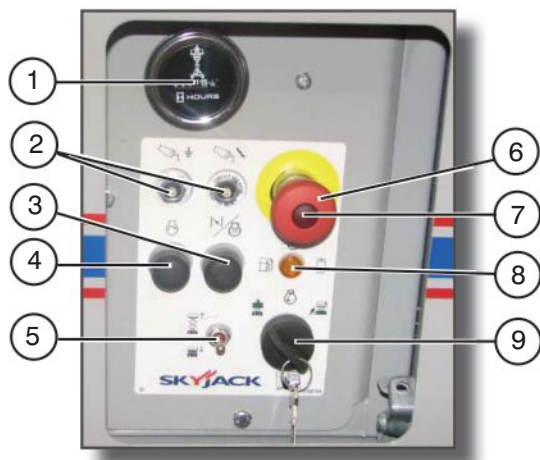

Figure 2-6. Base Control Console - Diesel

1. **Hourmeter** - This gauge records accumulated operating time of engine.
2. **Circuit Breakers** - In the event of a power overload or positive circuit grounding, the circuit breaker pops out. Push breaker back in to reset.
3. **Choke Pushbutton (Dual Fuel)** - This pushbutton switch aids in starting a cold dual-fuel engine.

Glow Plug Pushbutton (Diesel) - This pushbutton switch energizes the glow plugs to aid in starting a cold diesel engine.

4. **Engine Start Pushbutton** - This pushbutton “🔌” energizes the engine starter motor.
5. **Platform Raise/Lower Switch** - This switch controls “⬆️” raising or “⬇️” lowering of platform.
6. **Emergency Stop Button** - This button “🛑”, when depressed, disconnects power to control circuit and shuts engine off.
7. **Power Indicator Light** - When the emergency stop button on the base control console and on the platform control console are both pulled out, this light glows.

Fuel Switch (Dual Fuel) - Used to switch between “🔪” liquid propane gas and “🛢️” gasoline.
8. **Glow Plug Indicator Light (Diesel)** - This red lamp “💡” illuminates until the glow plugs have completed their timed heating cycle. When the lamp goes out, the engine is ready to be started.
9. **Platform/Engine/Base Key Switch** - This three-way selector switch allows the operator to turn the “🔌” engine in an idling mode or to activate either the “🏠” base or “🏗️” platform controls.

2.5-10 Maintenance Support

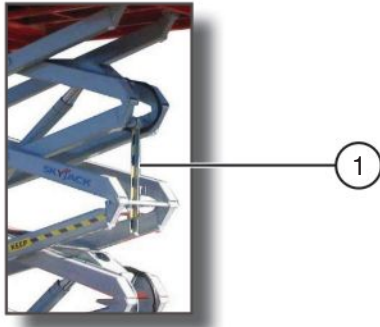

Figure 2-7. Maintenance Support

1. **Maintenance Support** - The maintenance support is a safety mechanism designed to support the scissor assembly. When properly positioned it can support the scissor assembly and empty platform. The maintenance support must be used when inspection and/or maintenance is to be performed within the lifting mechanism. Refer to [Section 2.17](#) for how to use the maintenance support.



WARNING

The maintenance support must be used when inspection and/or maintenance or repairs are to be performed within the lifting mechanism. Failure to use this safety mechanism could result in death or serious injury.



WARNING

Do not reach through the scissor assembly when the platform is raised without the maintenance support properly positioned. Failure to avoid this hazard could result in death or serious injury.

2.5-11 Manual Storage Box

This weather-resistant box is mounted on the platform railings. It contains the operating manual, EC declaration and other important documentation. The operating manual for this make and model of aerial platform must be stored in this box.



2.5-12 Platform Control Console

This removable control console is mounted at the right front of the platform. It contains the following controls:

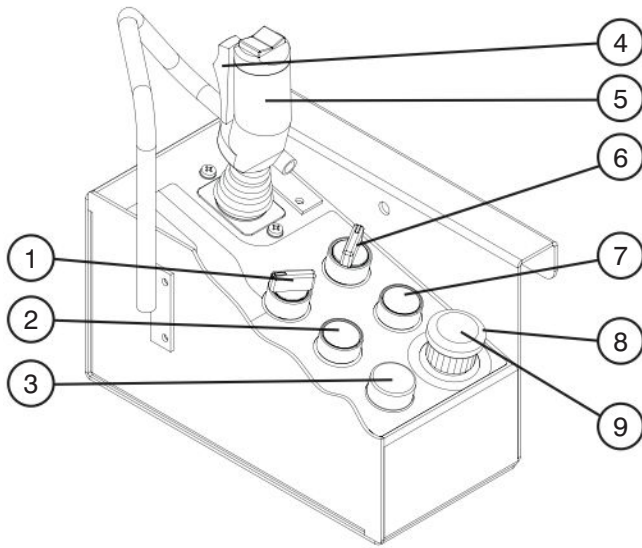

Figure 2-8. Platform Control Console

1. **Lift/Torque/Drive Switch** - This selector switch, when in “” lift position, allows lift functions to operate. When in “” low speed position, it allows drive functions to operate at low speed and maximum torque when climbing grades and on rough terrain. When in “” high speed position, it allows drive functions to operate at high speed with minimum torque.
2. **Engine Start Pushbutton** - This “” pushbutton energizes the engine starter motor.

NOTE

The engine start pushbutton is interlocked with the oil pressure switch. If engine stalls or does not start immediately, this button will not work for a few seconds while oil pressure bleeds off.
3. **Horn Pushbutton** - This “” pushbutton sounds an automotive-type horn.
4. **Lift/Drive/Steer Enable Trigger Switch** - This momentary “” switch energizes the controller. It must be held depressed continuously while engaging either the lift/drive or steer functions.
5. **Lift/Drive/Steer Controller** - This one-hand lever controls lift/drive and steer motions. Internal springs return it to neutral when controller is released.
6. **Low/High Throttle Switch** - This rotary switch allows selection between “” low and “” high engine throttle speeds.
7. **Choke Pushbutton (Dual Fuel)** - This pushbutton sets the “” choke for starting a cold gasoline/propane engine.

Glow Plug Pushbutton (Diesel) - This pushbutton energizes the “” glow plugs to aid in starting a cold diesel engine.
8. **Emergency Stop Button** - This button “”, when depressed, disconnects power to the control circuit.
9. **Power Indicator Light** - This light glows when “” platform is selected from the platform/engine/base key switch on the base control console. It also glows when both emergency stop buttons on the platform control console and the base control console are pulled out. When the light is flashing, it signals an overload function. Refer to [Section 2.5-4](#).

2.5-13 Folding Guardrail System

This system, when folded down, reduces the height of the retracted aerial platform for transporting and traveling through doorways only. Refer to [Section 2.13](#) for guardrail folding procedure.



WARNING

The scissor assembly must be fully lowered before raising or lowering the guardrails.



WARNING

Any lowered guardrail will create a fall hazard. Remain away from the sides of the platform while raising or lowering the guardrails to avoid falling. Refer to [Section 2.13](#), for guardrail folding procedure.

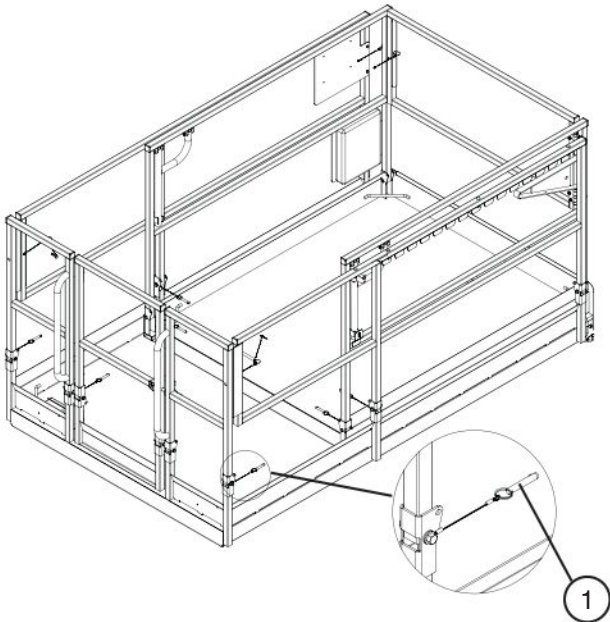

Figure 2-9. Folding Guardrail System

1. **Guardrail Locking Pin with Lanyard** - This pin is used to lock the guardrail in place.



WARNING

Before operating this aerial platform check the guardrail system for loose or missing locking pins. The guardrail system must be upright and all pins must be locked in place.

Death or serious injury could result if the guardrail system is not upright or properly locked.

2.5-14 Safety Belt/Harness Attachment Bar

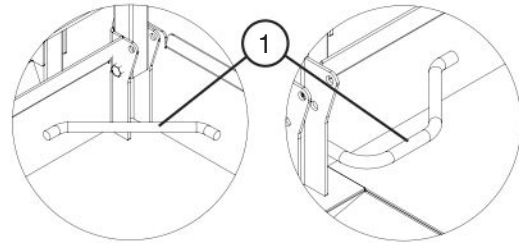

Figure 2-10. Safety Belt/Harness Attachment Bar

1. **Lanyard Attachment Anchorage** - Use this as an attachment point for safety belt/harness tethers. Do not attach belts/harnesses to any other point on the platform. Do not use this to lift, anchor, secure or support the platform or any other apparatus or material.



WARNING

The lanyard attachment anchorage is used for travel restraint, within the limits of the platform only. It is not a fall arresting device! Used as such could result in death or serious injury.

2.6 Component Identification (Special Options)

This section describes the components that are optional to aerial platforms.

2.6-1 Outrigger/Generator Control Console (Auto-leveling) (If Equipped)

The outrigger/generator control console is located next to the platform control console. These switches control the generator, and outriggers' extension and retraction.

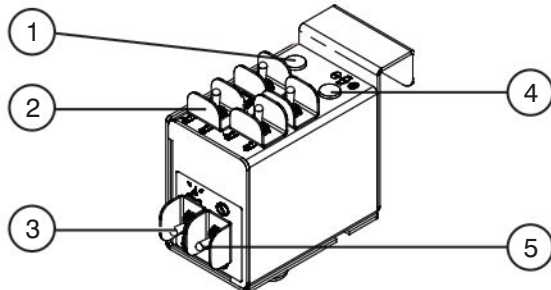









Figure 2-11. Outrigger/Generator Control Console with All Options

1. **Generator Switch** - This switch activates the generator.
2. **Outrigger Extend/Retract Switches** - These switches control the extension or retraction of each individual outrigger.
3. **Auto-Level Switch** - In the “” extend position, each outrigger extends and automatically adjusts until aerial platform is level. In the “” retract position, the outriggers retract.
4. **Outrigger Enable Switch** - This “” outrigger enable switch, when in the extend or retract position, activates functions on the auto-level switch and outrigger extend/retract switches.

5. **Leveling Indicator Light** - This light illuminates to display the status of the outriggers when the auto and manual level functions are in use. The indicator light has the following states:

-  **Off:** The outriggers are fully retracted.
-  **Flashing Rapidly:** The outriggers are extending but the platform is not level.
-  **Flashing:** The outriggers are extended but the platform is not yet level.
-  **Solid:** The outriggers are extended and the platform is level.

2.6-2 800W AC Inverter (If Equipped)

The inverter is located on the base of the aerial platform. It has the following controls:

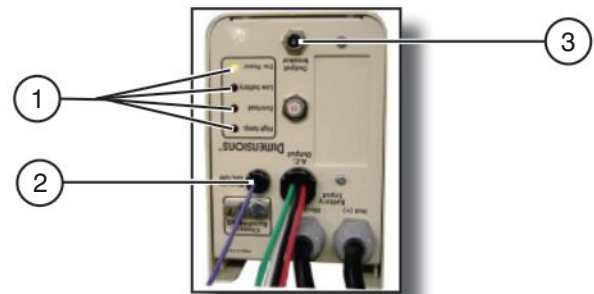

Figure 2-12. 800W AC Inverter

NOTE

The inverter operation is automatic. These controls do not need to be manipulated for normal operation.

1. **Status LEDs** - These LEDs indicate the operating or fault status of the inverter.
2. **ON/OFF Wire** - This wire is the connection to turn the inverter on.
3. **15 Amp Circuit Breaker** - In the event of a power overload or circuit grounding, the circuit breaker pops out. Push the breaker back in to reset.

2.7 Operator's Responsibility

It is the responsibility of the operator, prior to each work shift, to perform the following:

1. Visual and Daily Maintenance Inspections

- are designed to discover any damage of components before the aerial platform is put into service.
- are done before the operator performs the function tests.



WARNING

Failure to locate and repair damage, and discover loose or missing parts may result in an unsafe operating condition.

2. Function Tests

- are designed to discover any malfunctions before the aerial platform is put into service.

IMPORTANT

The operator must understand and follow the step-by-step instructions to test all aerial platform functions.

The operator should make a copy of the Operator's Checklist (see [Table 2.8](#)) and fill out the visual and daily maintenance inspections and the function tests sections while performing the items outlined in [Section 2.8](#) and [Section 2.9](#).

IMPORTANT

If aerial platform is damaged or any unauthorized variation from factory-delivered condition is discovered, aerial platform must be tagged and removed from service.

Repairs to the aerial platform may only be made by a qualified service technician. After repairs are completed, the operator must perform visual and daily maintenance inspections & function tests again.

Scheduled maintenance inspections shall only be performed by qualified service technician (see [Table 2.7](#)).

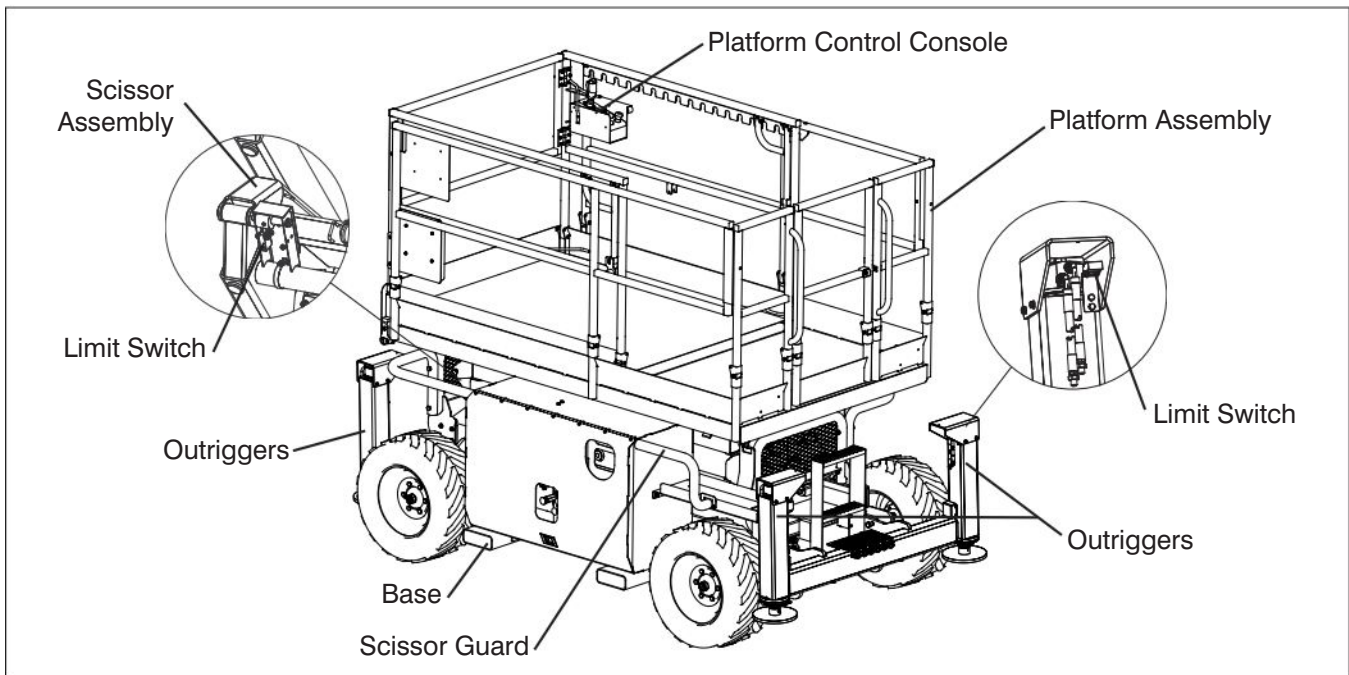

2.8 Visual & Daily Maintenance Inspections

Begin the visual and daily maintenance inspections by checking each item in sequence for the conditions listed in this section.



WARNING

To avoid injury, do not operate an aerial platform until all malfunctions have been corrected.



WARNING

To avoid possible injury, ensure aerial platform power is off during your visual and daily maintenance inspections.

NOTE

While doing visual and daily inspections in different areas, be aware to also inspect limit switches, electrical and hydraulic components.

2.8-1 Labels

Refer to the labels section in this manual and determine that all labels are in place and are legible.

2.8-2 Electrical

Maintaining the electrical components is essential to good performance and service life of the aerial platform.

Inspect the following areas for chafed, corroded and loose wires:

- base to platform cables and wiring harness
- engine compartment electrical panel
- engine wiring harness
- hydraulic/electrical wiring harnesses

2.8-3 Limit Switches

Ensure limit switches are properly secured with no signs of visible damage and movement is not obstructed.

2.8-4 Hydraulic

Maintaining the hydraulic components is essential to good performance and service life of the aerial platform.

Perform a visual inspection around the following areas:

- hydraulic tank filter, fittings, hoses, emergency power unit (if equipped) and base surfaces
- engine compartment fittings, hoses, main pump, and filter
- all hydraulic cylinders
- all hydraulic manifolds
- the underside of the base
- ground area under the aerial platform
- outriggers

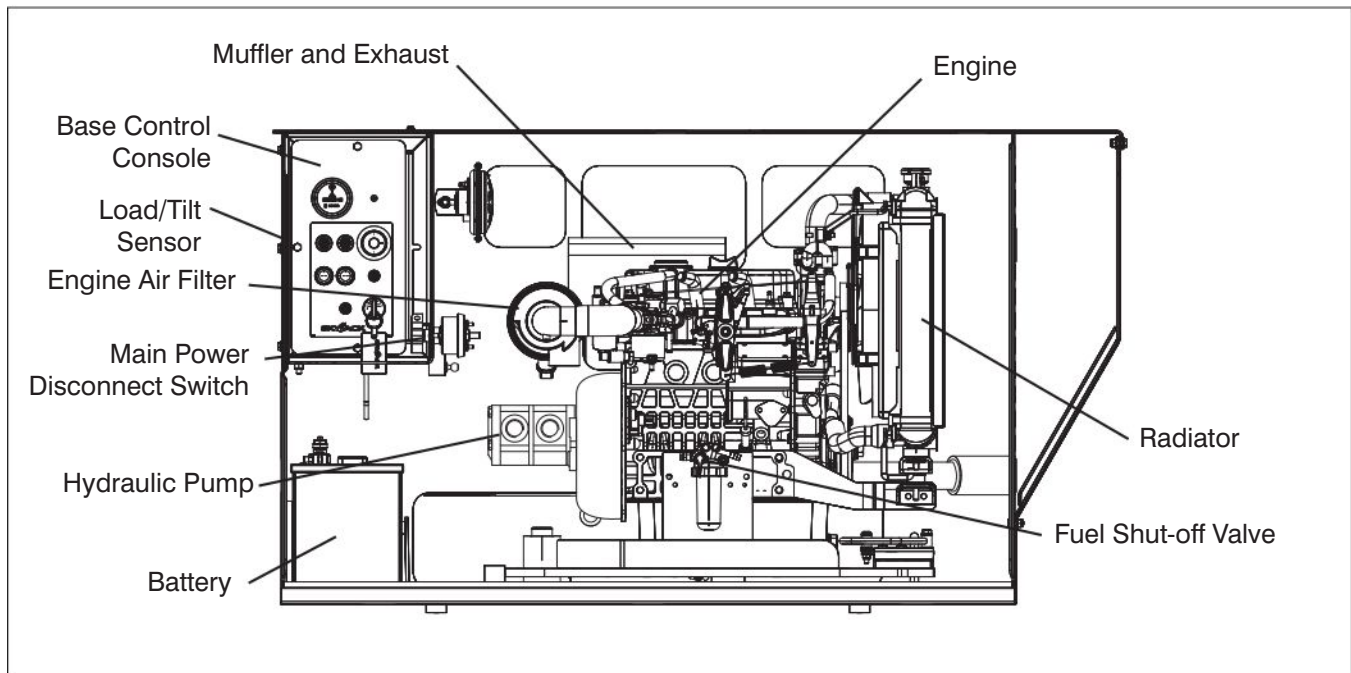

2.8-5 Engine Compartment

- Ensure compartment latch is secure and in proper working order.
- **Main Power Disconnect Switch**
 - Turn main power disconnect switch to “○” off position.
 - Ensure all cables are secure and switch is in proper working condition.
- **Base Control Switches**
 - Ensure there are no signs of visible damage and all switches are in their neutral positions.
- **Load/Tilt Sensor**
 - Ensure load/tilt sensor is properly secure and there is no visible damage.
- **Battery**

Proper battery condition is essential to good performance and operational safety. Improper fluid levels or damaged cables and connections can result in component damage and hazardous conditions.



WARNING

Explosion hazard. Keep flames and sparks away. Do not smoke near batteries.



WARNING

Battery acid is extremely corrosive - Wear proper eye and facial protection as well as appropriate protective clothing. If contact occurs, immediately flush with cold water and seek medical attention.

1. Check battery case for damage.
2. Clean battery terminals and cable ends thoroughly with a terminal cleaning tool or wire brush.
3. Ensure all battery connections are tight.
4. If applicable, check battery fluid level. If plates are not covered by at least 13 mm of solution, add distilled or demineralized water.
5. Replace battery if damaged or incapable of holding a lasting charge.



WARNING

Use original or manufacturer-approved parts and components for the aerial platform.

- **Hydraulic Pump**
 - Ensure there are no loose or missing parts and there is no visible damage.

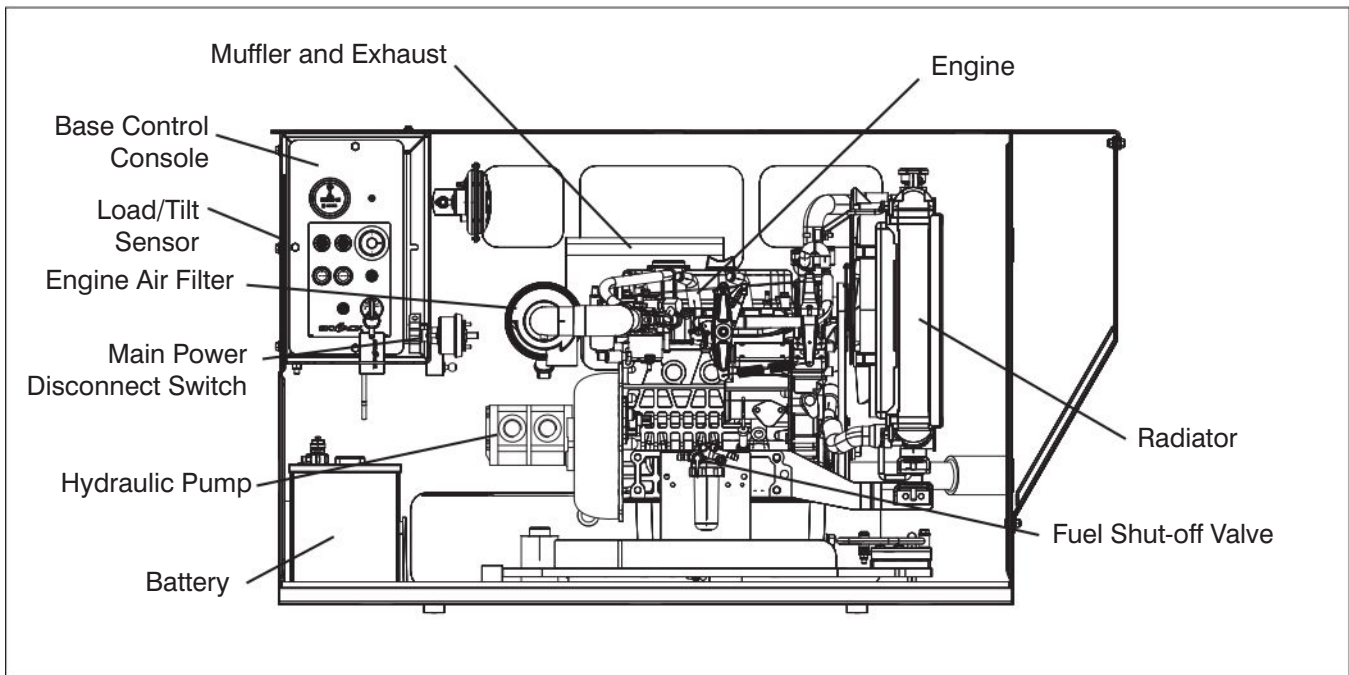

- Ensure all bolts are properly tightened.
- Ensure all fittings and hoses are properly tightened and there is no evidence of hydraulic leakage.
- **Radiator**
 - Ensure radiator is secure.
 - Ensure there are no loose or missing parts and there is no visible damage.
 - Check coolant level and add as needed.
- **Muffler and Exhaust**
 - Ensure muffler and exhaust system are properly secured, with no evidence of damage.
- **Engine Pivot Tray**
 - Ensure there are no loose or missing parts and no visible damage to the engine pivot tray. Ensure that both tray-securing bolts are in place.
- **Engine Oil Level**
 - Maintaining the engine components is essential to good performance and service life of the aerial platform.

Check oil level on dipstick

- Oil level should be in the “safe” zone. Add oil as needed.

- **Fuel Shut-off Valve**
 - Ensure there are no loose or missing parts and there is no visible damage.
- **Engine Air Filter**
 - Ensure there are no loose or missing parts and there is no visible damage.
- **Fuel Leaks**

Failure to detect and correct fuel leaks will result in an unsafe condition. An explosion or fuel fire may cause death or serious injury.



DANGER

Engine fuels are combustible. Inspect the aerial platform in an open, well-ventilated area away from heaters, sparks and flames. Always have an approved fire extinguisher within easy reach.

Perform a visual inspection around the following areas:

- hoses and fittings
- fuel pump
- fuel filter



WARNING

Beware of hot engine components.

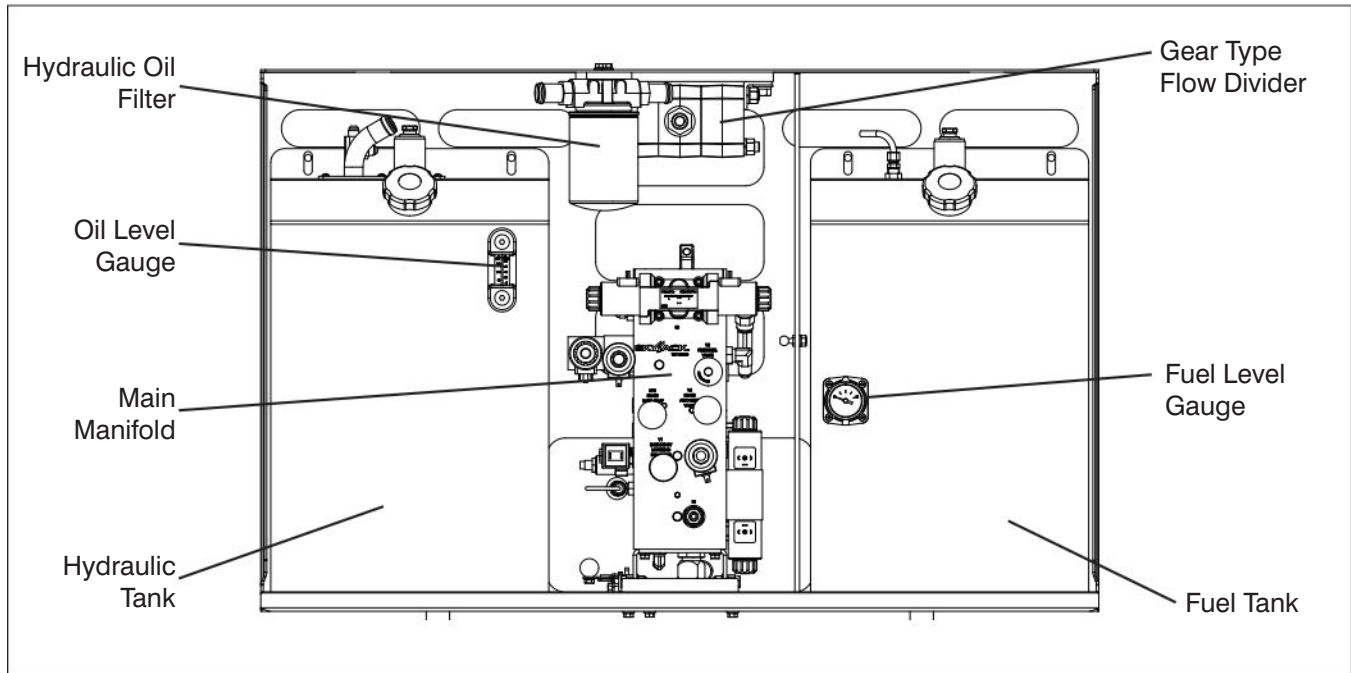

2.8-6 Hydraulic/Fuel Compartment

- Ensure compartment latch is secure and in proper working order.
- **Hydraulic Tank**
 - Ensure hydraulic filler cap is secure.
 - Ensure tank shows no visible damage and no evidence of hydraulic leakage.
- **Hydraulic Oil**
 - Ensure platform is fully lowered, and then visually inspect the sight gauge located on the side of the hydraulic oil tank.
 - The hydraulic oil level should be at or slightly above the top mark of the sight glass.
- **Hydraulic Return Filter**
 - Ensure filter element is secure.
 - Ensure there are no signs of leakage or visible damage.

- **Fuel Tank**

IMPORTANT

Before using your aerial platform ensure there is enough fuel for expected use.

- Ensure fuel filler cap is secure.
- Ensure tank shows no visible damage and no evidence of fuel leakage.
- **Fuel Leaks**
Failure to detect and correct fuel leaks will result in an unsafe condition. An explosion or fuel fire may cause death or serious injury.



DANGER

Engine fuels are combustible. Inspect the aerial platform in an open, well-ventilated area away from heaters, sparks and flames. Always have an approved fire extinguisher within easy reach.

Perform a visual inspection around the following areas:

- fuel tank
- hoses and fittings

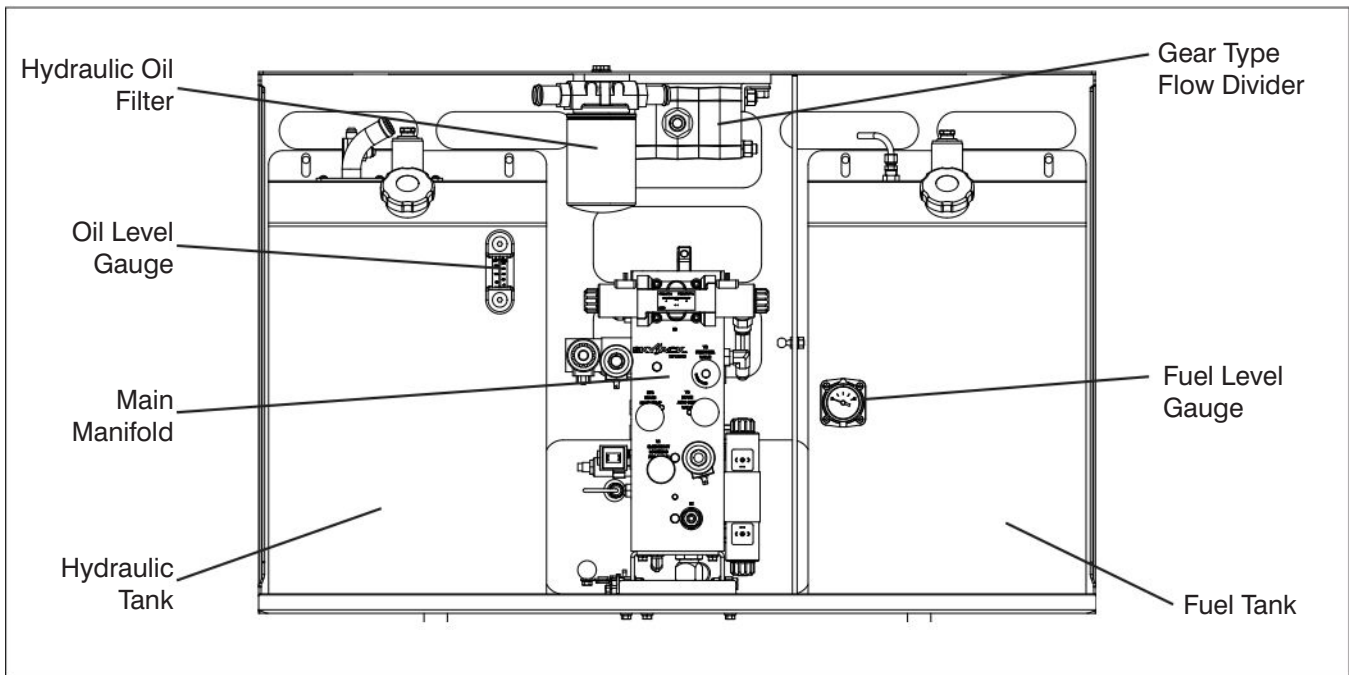

- **Main Manifold**
 - Ensure all fittings and hoses are properly tightened and there is no evidence of hydraulic leakage. Pull and tilt main manifold to check thoroughly.
 - Ensure there are no loose wires or missing fasteners.
 - Restore to original position.
- **Gear Type Flow Divider**
 - Ensure there are no loose or missing parts and there is no visible damage.

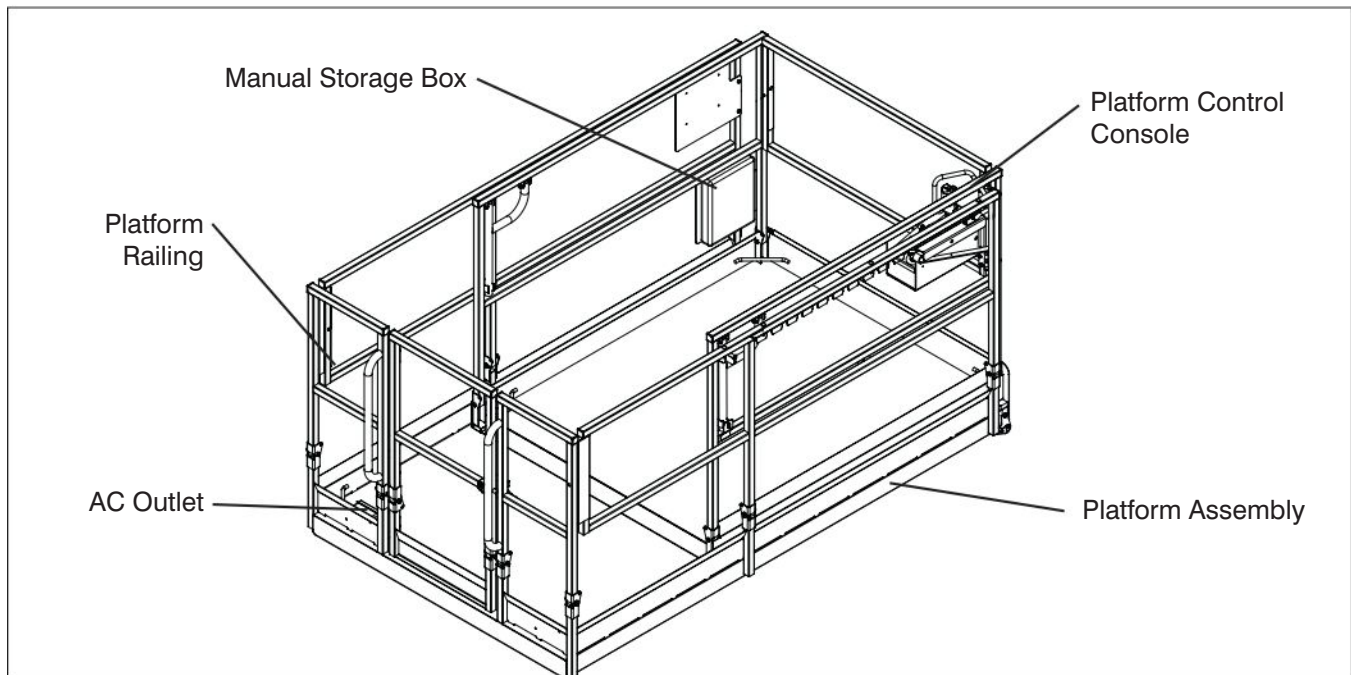

2.8-7 Platform Assembly



WARNING

Ensure that you maintain three points of contact to mount/dismount platform.

1. Use the ladder of aerial platform to access platform.
2. Close the gate.
 - Ensure there are no loose or missing parts and there is no visible damage.
 - Ensure all fasteners are securely in place.
 - Ensure all railings are properly positioned and secured.
 - Ensure gate is in good working order.
- **Lanyard Attachment Anchors**
 - Ensure attachment rings are secure and no visible damage.

- **AC Outlet on Platform**

- Ensure outlet has no visible damage and free from dirt or obstructions.

- **Manuals**

Ensure a copy of operating manual and CE certificate are enclosed in manual storage box.

- Check to be sure manual storage box is present and in good condition.
- Ensure manuals are legible and in good condition.
- Always return manuals to the manual storage box after use.

- **Platform Control Console**

- Ensure all switches and controller are returned to neutral and are properly secured.
- Ensure there are no loose or missing parts and there is no visible damage.



WARNING

Ensure that you maintain three points of contact to mount/dismount platform.

3. Use the ladder to dismount from platform.

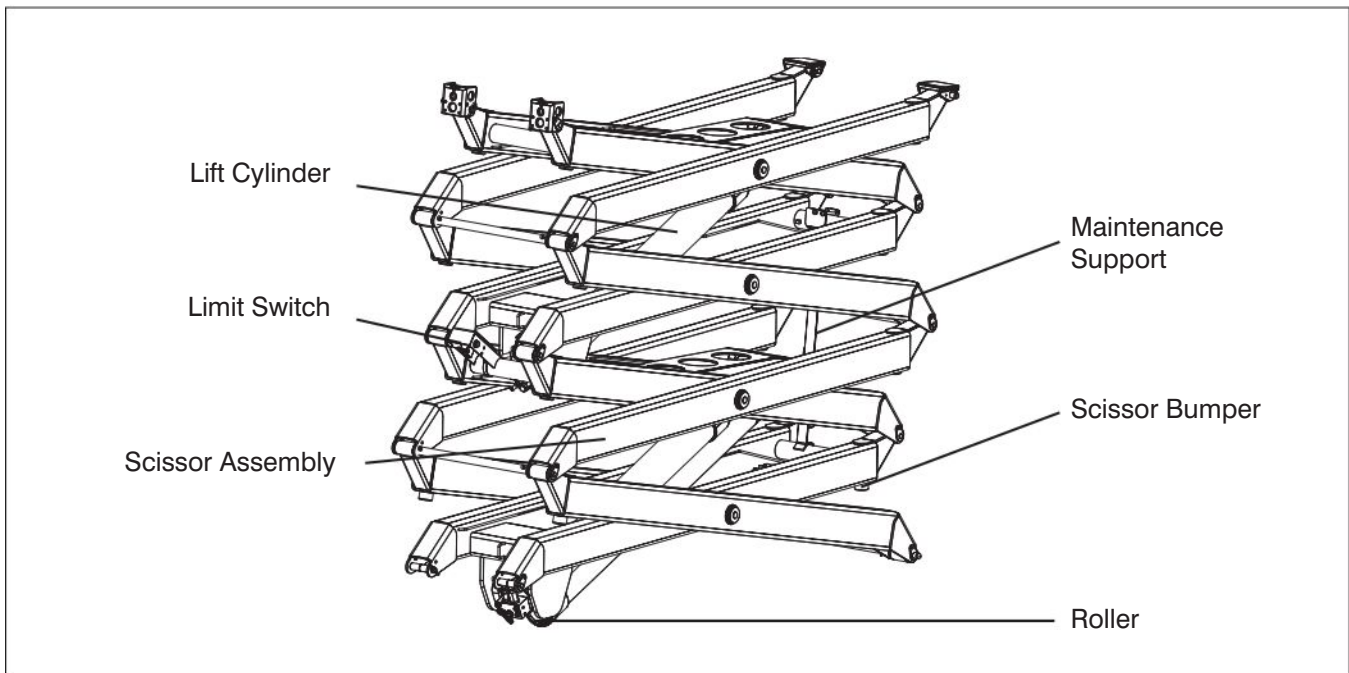

2.8-8 Lifting Mechanism

1. Raise the platform (refer to [Section 2.10-4](#)) until there is adequate clearance to swing down the maintenance support (refer to [Section 2.17](#)).

- **Maintenance Support**

- Ensure maintenance support is properly secured and shows no visible damage.

- **Scissor Assembly**

- Ensure scissor assembly shows no visible damage and no signs of deformation in weldments.
- Ensure all pins are properly secured.
- Ensure cables and wires are properly routed and shows no signs of wear and/or physical damage.

- **Scissor Bumpers**

- Ensure bumpers are secure and shows no sign of visible damage.

- **Rollers**

- Ensure rollers are secure and there is no visible damage.
- Ensure rollers' path of travel are free from dirt and obstructions.

- **Lift Cylinder(s)**

- Ensure each lift cylinder is properly secured, there are no loose or missing parts and there is no evidence of damage.
- Ensure all fittings and hoses are properly tightened and there is no evidence of hydraulic leakage.

2. Raise the platform until there is adequate clearance to swing up the maintenance support into storage bracket. Refer to [Section 2.17](#).

3. Fully lower the platform.

- **Scissor Guards**

- Ensure there are no loose or missing parts and there is no visible damage.

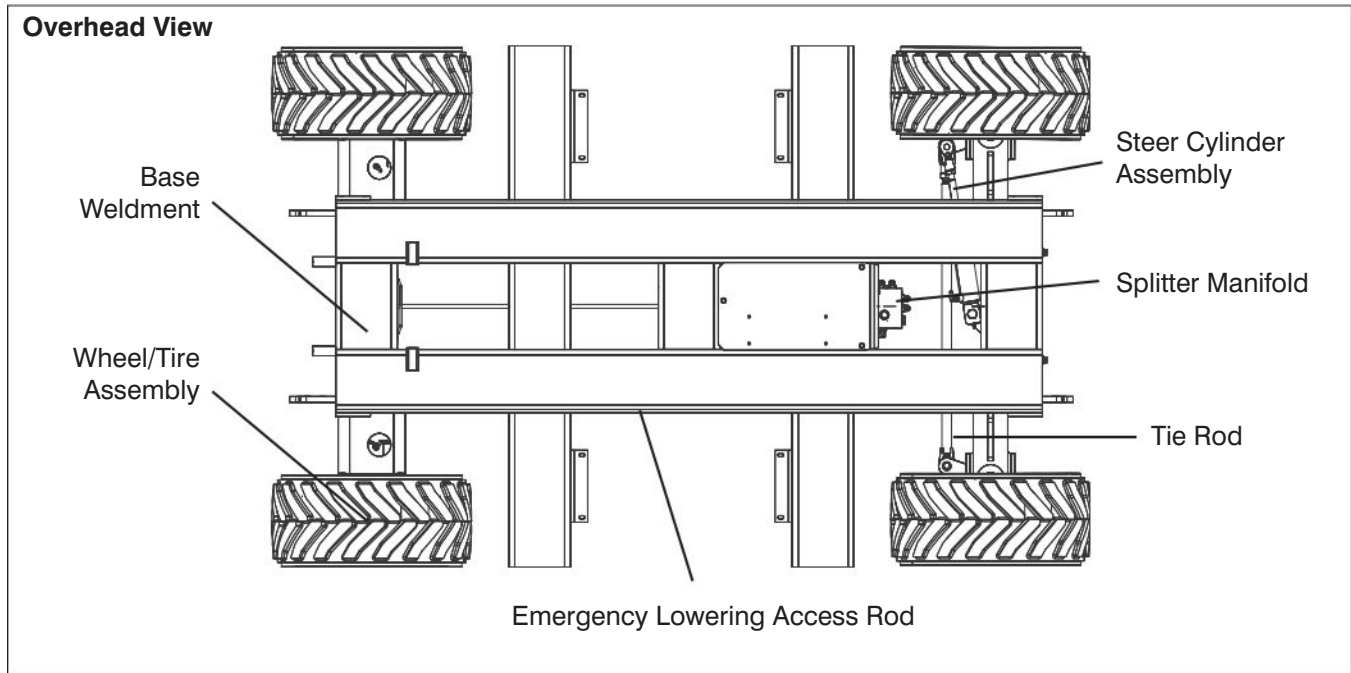

2.8-9 Base

- **Base Weldment**
 - Ensure there are no visible cracks in welds or structure and there are no signs of deformation.
- **Wheel/Tire Assembly**

The aerial platform is either equipped with air tires or foam-filled tires. Tire and/or wheel failure could result in an aerial platform tipover. Component damage may also result if problems are not discovered and repaired in a timely fashion.



WARNING

Air filled tires are not permitted on some models. Refer to Table 2.2.



WARNING

An over-inflated tire can explode and may cause death or serious injury.

- Check all tire treads and sidewalls for cuts, cracks, punctures and unusual wear.
- Check each wheel for damage and cracked welds.
- Check each lug nut for proper torque to ensure none are loose.
- Check wheel motor assembly for loose or missing parts and signs of visible damage (if equipped).
- Ensure wheels are aligned and true vertically and horizontally.

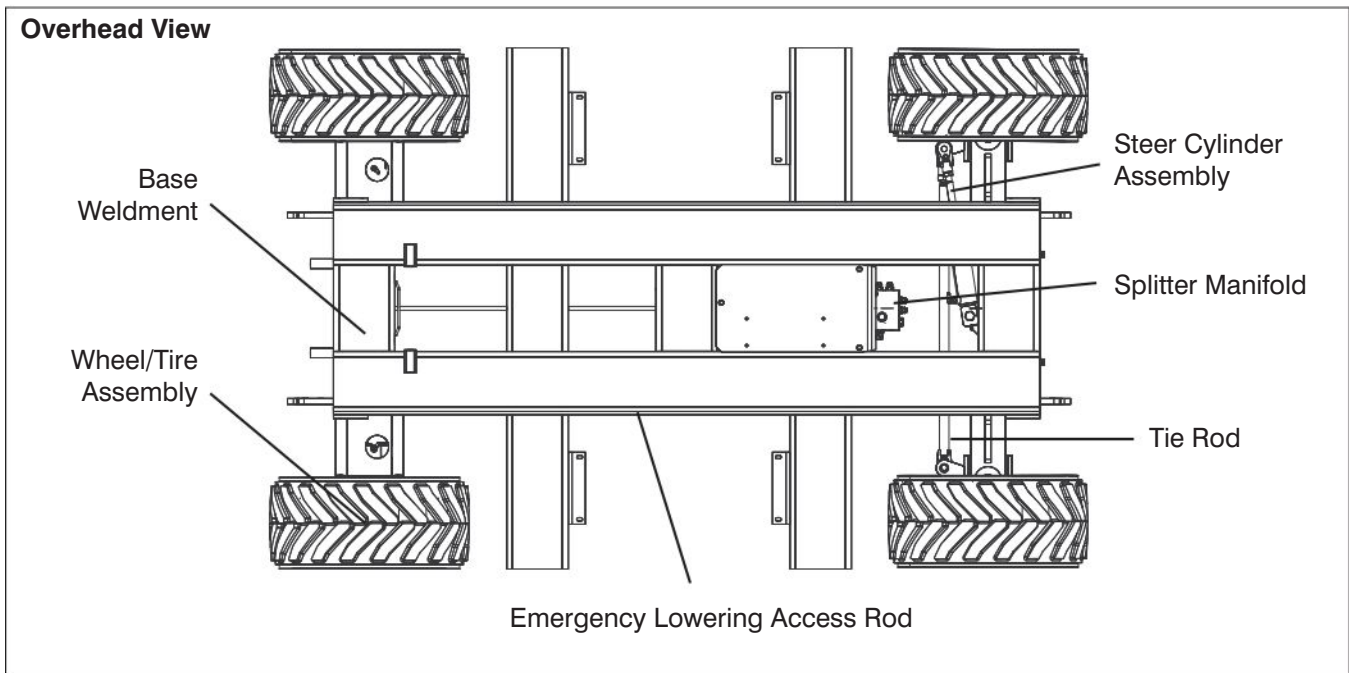

To safeguard maximum stability, achieve optimum aerial platform handling and minimize tire wear, it is essential to maintain proper pressure in all air-filled tires.

- Check each tire with an air pressure gauge and add air as needed.

Refer to [Table 2.2](#) for wheel/tire specifications.

- **Steer Cylinder Assembly**
 - Ensure steer cylinder assembly is properly secured, there are no loose or missing parts, all fittings and hoses are properly tightened and there is no evidence of hydraulic leakage.
- **Splitter Manifold**
 - Ensure all fittings and hoses are properly tightened and there is no evidence of hydraulic leakage.

- **Tie Rod**
 - Ensure there are no loose or missing parts, tie rod end studs are locked and there is no visible damage.
- **Emergency Lowering Access Rod**
 - Ensure rod is properly secured and there is no visible damage.
- **Ladder**
 - Ensure there are no loose or missing parts and there is no visible damage.
- **Outriggers**
 - Ensure there are no loose or missing parts and there is no visible damage.

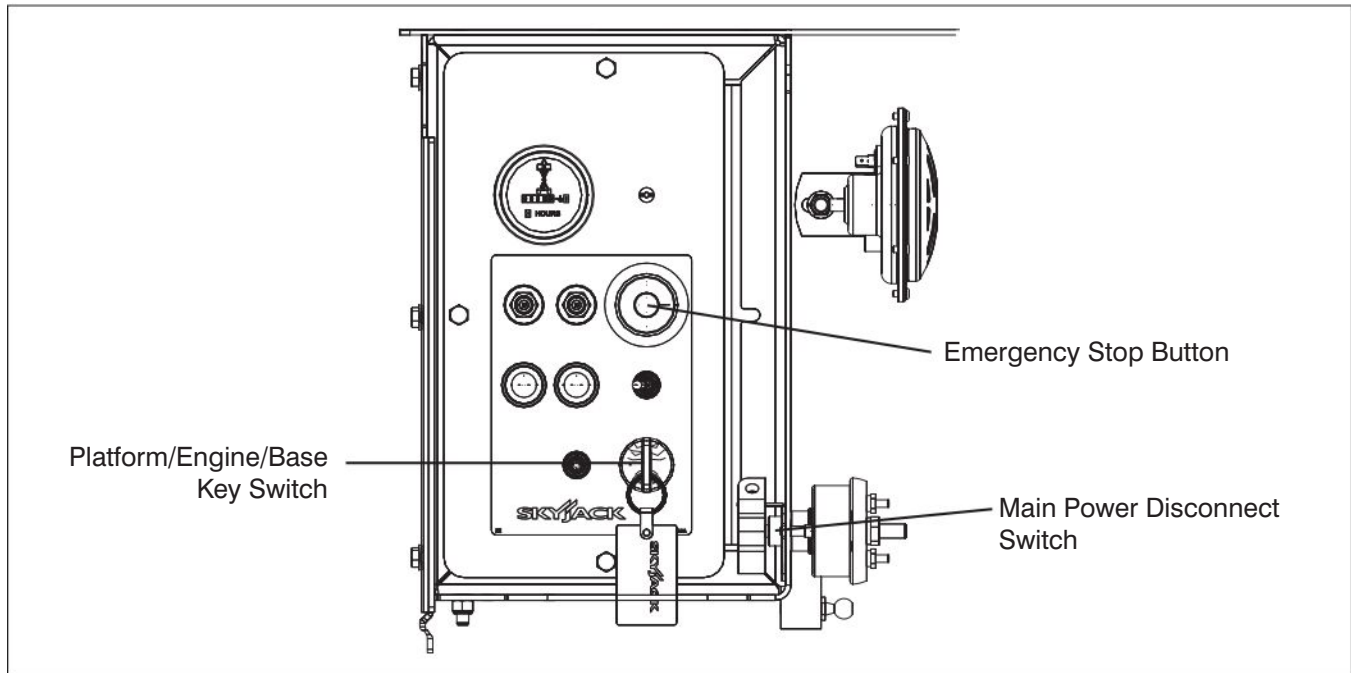

2.9 Function Tests

Function tests are designed to discover any malfunctions before aerial platform is put into service. The operator must understand and follow step-by-step instructions to test all aerial platform functions.

IMPORTANT

Never use a malfunctioning aerial platform. If malfunctions are discovered, aerial platform must be tagged and placed out of service. Repairs to aerial platform may only be made by a qualified service technician.

After repairs are completed, operator must perform a pre-operation inspection and a series of function tests again before putting aerial platform into service.

Prior to performing function tests, be sure to read and understand [Section 2.10](#) - Start Operation.

2.9-1 Test Main Power Disconnect Switch

1. In engine compartment, turn main power disconnect switch to "O" off position.
Result: Aerial platform functions should not operate.

2.9-2 Base Control Console



WARNING

Ensure that you maintain three points of contact when using the ladder to mount/dismount platform.

1. Use the ladder of aerial platform to access platform.
2. Close the gate.
3. On platform control console, pull out "E" emergency stop button.
4. Select low/high throttle switch to "L" low throttle position.
5. Use the ladder to dismount from platform.
6. Turn main power disconnect switch to "I" on position.

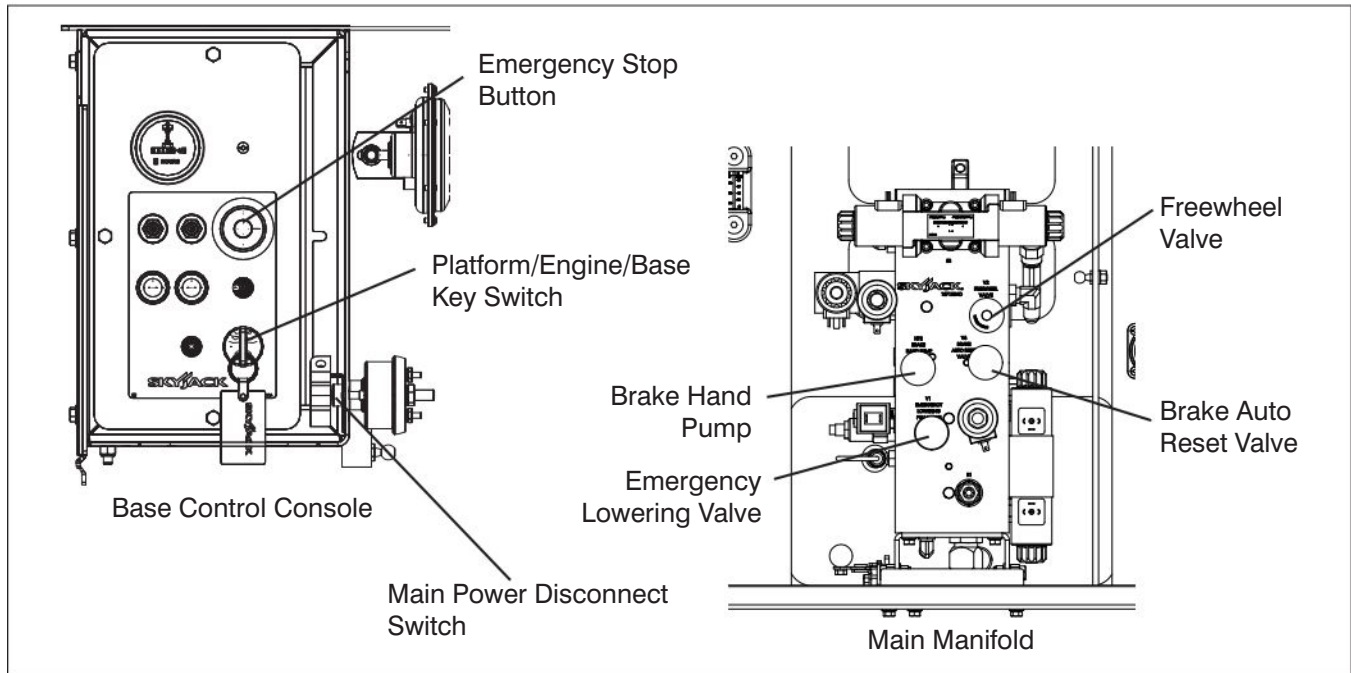



• **Test Platform/Engine/Base Key Switch**





WARNING



Be aware of overhead obstructions or other possible hazards around the aerial platform when lifting.

1. Pull out base “” emergency stop button.
2. Insert key into platform/engine/base key switch, select “” engine position and attempt to start engine.
Result: Engine should not start.
3. With key inserted into platform/engine/base key switch, select “” base position and attempt to start engine.
Result: Engine should start.

• **Test Emergency Stop**

1. Push in “” emergency stop button.
Result: Engine should shut down and aerial platform functions should not operate.
2. Pull out “” emergency stop button and restart engine.

• **Test Platform Raise/Lower Switch**

1. Select platform/engine/base key switch to “” base position and raise or lower the platform with platform “” raise or “” lower switch.
Result: Platform raising and lowering functions should operate.

• **Test Emergency Lowering**

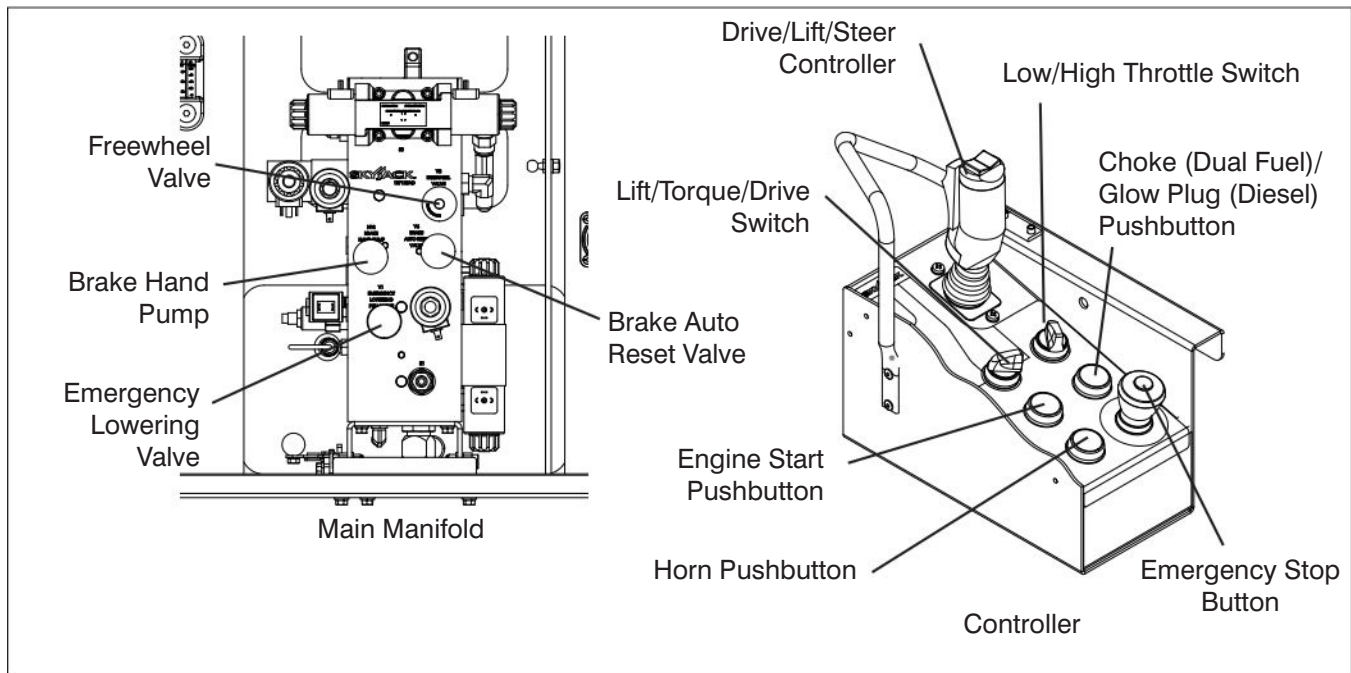

1. Raise the platform.
2. Locate holding valve manual override knob at the base of each lift cylinder. Depress and turn counterclockwise. If necessary, use access rod that is located on the base of the aerial platform.
3. On hydraulic/fuel compartment, pull out and hold emergency lowering valve to fully lower the platform.
Result: The platform should lower.
4. To restore normal operation, depress and turn holding valve manual override knobs clockwise.



- **Test Free-wheeling**

1. Ensure path of intended motion is clear.
2. Release the brake manually (refer to [Section 2.15-2](#)).
3. Turn free-wheeling valve knob counterclockwise to a fully opened position and attempt to push/pull the aerial platform.
Result: Aerial platform should move.
4. Turn free-wheeling valve knob clockwise to a fully closed position for normal operation.
5. Reengage the brake (refer to [Section 2.15-2](#)).

2.9-3 Platform Control Console

1. Ensure base “” emergency stop button is pulled out.
2. Ensure main power disconnect switch is in “” on position.
3. Select platform/engine/base key switch to “” platform position and remove key.



WARNING

Ensure that you maintain three points of contact when using the ladder to mount/dismount platform.

4. Use the ladder of aerial platform to access platform.
5. Close the gate.
6. On platform control console, pull out “” emergency stop button.

- **Test Emergency Stop**

1. Ensure engine is running.
2. Push in “” emergency stop button.
Result: Engine should shut down and aerial platform functions should not operate.

- **Test Enable Trigger Switch**

1. Ensure engine is running.
2. Without activating “” enable trigger switch, attempt to activate any platform function.
Result: All platform functions should not operate.

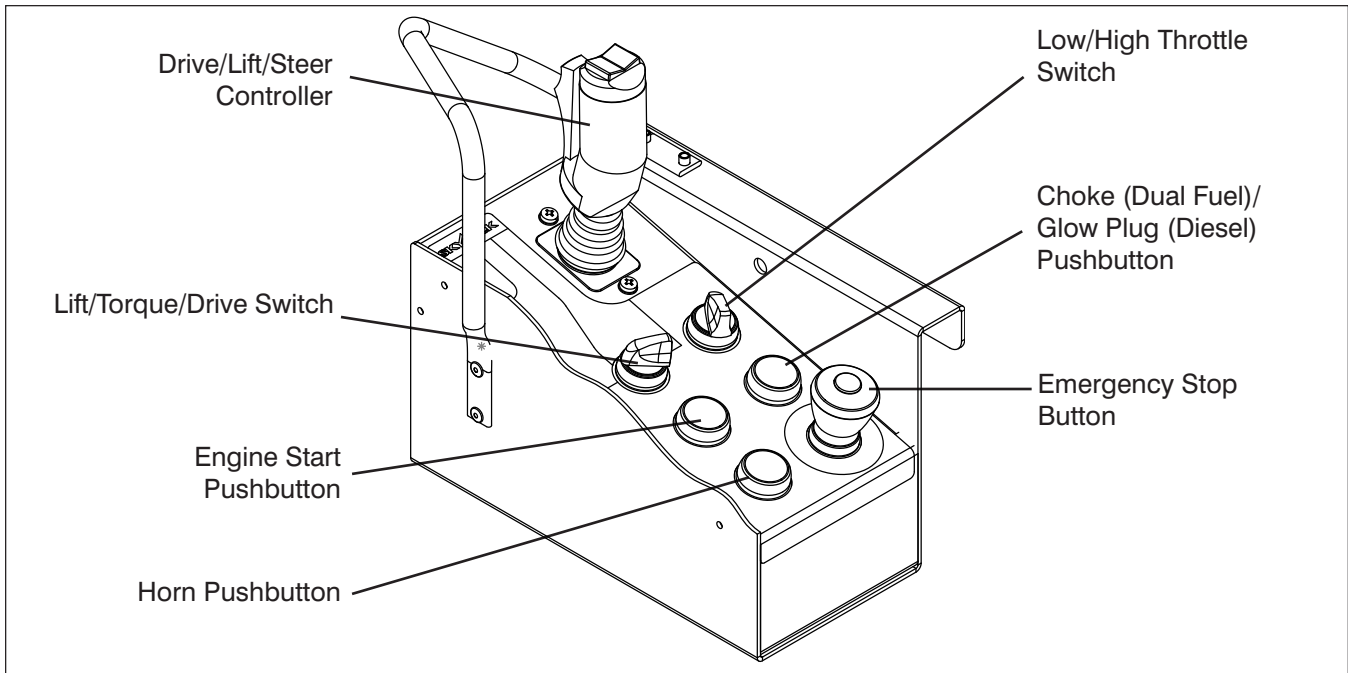



• **Test Platform Raising/Lowering**



WARNING



Be aware of overhead obstructions or other possible hazards around the aerial platform when lifting.

1. Select lift/torque/drive switch to “” lift position.
2. Activate and hold “” enable trigger switch.
3. Push or pull controller handle until desired height is reached.
Result: Platform raising and lowering functions should operate.

• **Test Lowering Warning**



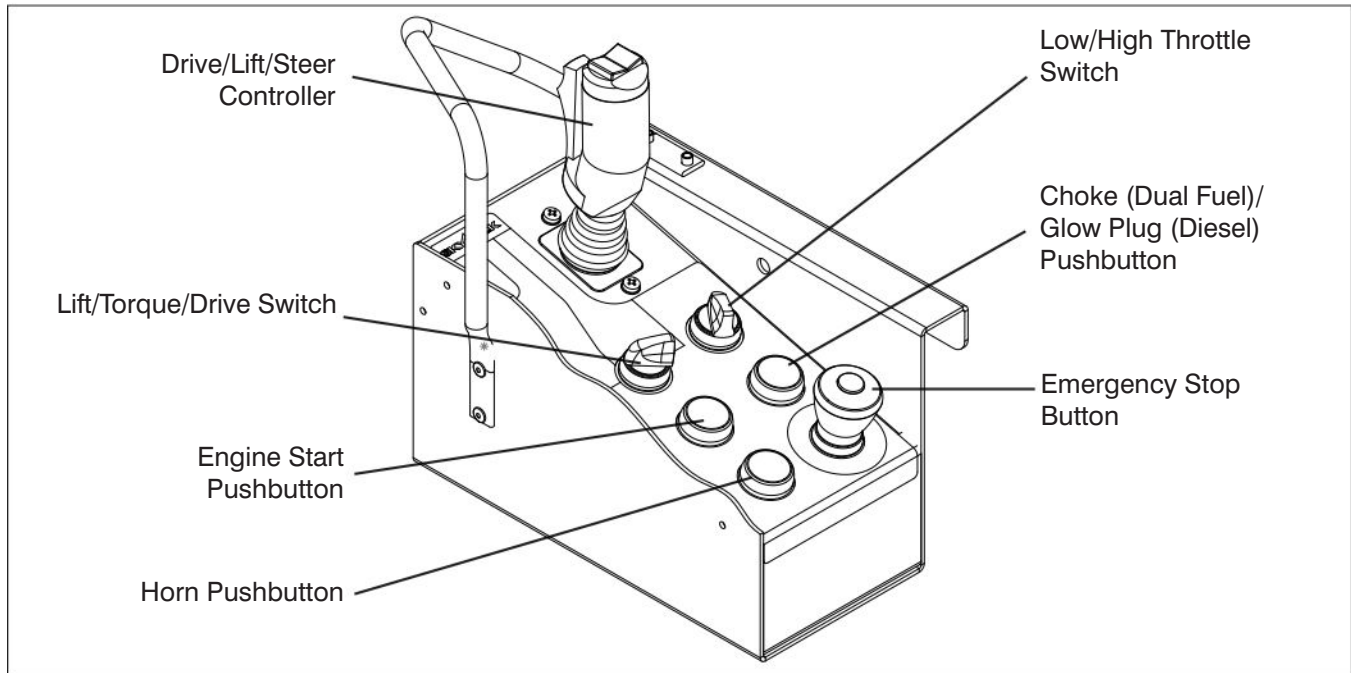

1. Raise the platform until approximately a height of 3 to 4 meters is reached then attempt to fully lower the platform.
Result: Platform should stop lowering at a height of 2.5 meters high and an alarm should sound.
2. Release controller handle, ensure area around scissor is clear, then continue lowering the platform.

• **Test Steering**

1. Ensure engine is running.
2. Press rocker switch on top of controller to “” left and “” right.
Result: Steer wheels should turn left and right.



- **Test Driving**

1. Ensure path of intended motion is clear.
2. On platform control console, select lift/torque/drive switch to “” drive position.
3. Activate and hold “” enable trigger switch.
4. Slowly move controller in “” forward or “” reverse direction until aerial platform begins to move, and then return handle to center position.
Result: Aerial platform should move in forward or reverse direction, and then come to a stop.

- **Test Speed Limit**



WARNING

Be aware of overhead obstructions or other possible hazards around the aerial platform when lifting.

1. Ensure path of intended motion is clear.
2. Raise the platform until approximately a height of 2 meters is reached and attempt to drive forward or reverse.
Result: Aerial platform should move slower than when it is in stowed position.

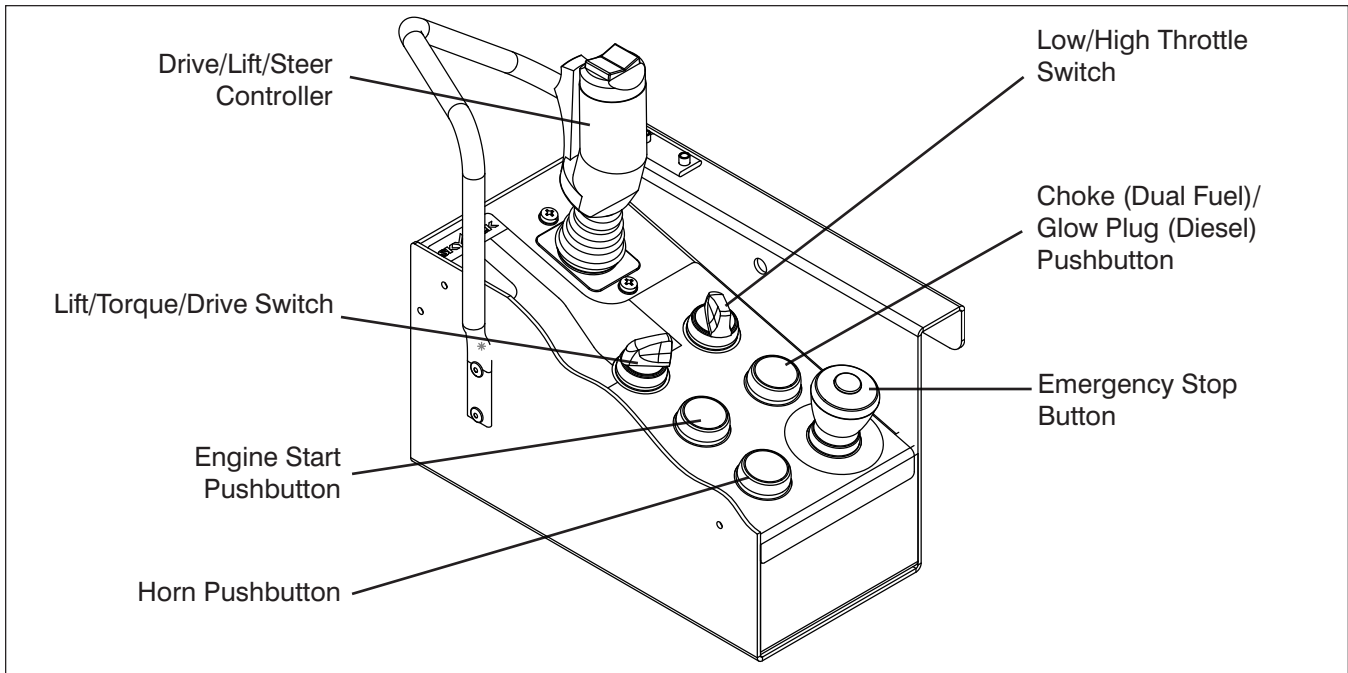





• **Test Brakes**



WARNING

Brakes will engage instantly when you release the controller handle, causing aerial platform to stop immediately.

1. Ensure path of intended motion is clear.
2. Activate and hold “” enable trigger switch.
3. Drive aerial platform “” forward. Test brake by releasing controller handle.
Result: Aerial platform should come to a stop. If aerial platform pulls to one side while stopping, do not operate aerial platform until brake adjustments have been checked.
4. Drive aerial platform “” forward. Test brake again by releasing “” enable trigger switch only.
Result: Aerial platform should come to an instant and abrupt stop. If aerial platform does not stop immediately, or if aerial platform pulls to one side while stopping, do not operate aerial platform until brake adjustments have been checked.

• **Test Horn**

1. Push “” horn pushbutton.
Result: Horn should sound.

2.10 Start Operation

Carefully read and completely understand the operating manual and all warnings and instruction labels (refer to labels section) on the aerial platform.



WARNING

Do not operate this aerial platform without proper authorization and training. Failure to avoid this hazard could result in death or serious injury.

Before operating this aerial platform, perform the following steps:

1. Visual and daily maintenance inspections (see [Section 2.8](#))
2. Function tests (see [Section 2.9](#))
3. Jobsite inspection
It is the responsibility of the operator to perform a jobsite inspection and avoid the following hazardous situations:
 - holes or drop-offs
 - ditches or soft fills
 - floor obstructions, bumps or debris
 - overhead obstructions
 - electrical cords, hoses and high voltage conductors
 - hazardous locations
 - inadequate surface support to withstand all load forces imposed by the aerial platform
 - wind and weather conditions
 - the presence of unauthorized personnel
 - other possible unsafe conditions



WARNING

An operator should not use any aerial platform that:









- does not appear to be working properly.
- has been damaged or appears to have worn or missing parts.
- has alterations or modifications not approved by the manufacturer.
- has safety devices which have been altered or disabled.

Failure to avoid these hazards could result in death or serious injury.

2.10-1 To Activate Base Control Console



**WARNING**

Ensure that you maintain three points of contact when using the ladder to mount/dismount platform.

1. Use the ladder of aerial platform to access platform.
2. Close the gate.
3. On platform control console, pull out “” emergency stop button.
4. Select low/high throttle switch to “” low throttle position.
5. Use the ladder to dismount from platform.
6. Turn main power disconnect switch to “” on position.
7. On base control console, pull out “” emergency stop button.
8. For dual fuel engines, select fuel supply by moving fuel switch to either “” gasoline or “” liquid propane gas position.
9. Insert key into platform/engine/base key switch and select “” base position.
10. For cold dual fuel engines, depress and hold “” choke pushbutton. For cold diesel engines, depress and hold “” glow plug pushbutton for 15 to 20 seconds.

**CAUTION**

Do not start the engine in the high throttle position.

11. Depress and hold “” engine start pushbutton until engine starts, then release. Do not overcrank starter. Release “” choke pushbutton after engine starts (dual fuel).

NOTE

Choke is only active while button is depressed. Occasional use of choke button may be necessary during the first few seconds of engine operation.



2.10-2 To Raise or Lower Platform Using Base Control Console

**WARNING**

Be aware of overhead obstructions or other possible hazards around the aerial platform when lifting.





**WARNING**

Do not lower the platform unless the area below is clear of personnel and obstructions.

1. Activate base control console (refer to [Section 2.10-1](#)).
2. On base control console, select and hold “” base position on platform/engine/base key switch. Select and hold platform raise/lower switch to either “” raise or “” lower position. Release platform raise/lower switch to stop.





Lowering Warning System - A lowering warning system automatically stops the lowering function before reaching the fully retracted position and sounds the alarm. After the operator has released the down controls and taken time to check that no person is near the scissors, the lowering function can be reactivated.

2.10-3 To Activate Platform Control Console

1. Turn main power disconnect switch to “I” on position.
2. On the base control console, pull out the “” emergency stop button.
3. For dual fuel engines, select fuel supply by moving fuel switch to either “” gasoline or “” liquid propane gas position.
4. Insert key into platform/engine/base key switch and turn it to “” enable platform controls.



**WARNING**

Ensure that you maintain three points of contact when using the ladder to mount/dismount platform.

5. Use the ladder of aerial platform to access platform.
6. Close the gate.
7. On platform control console, pull out “” emergency stop button.
8. Turn the low/high throttle switch to “” low throttle position.
9. For cold dual fuel engines, depress and hold “” choke pushbutton. For cold diesel engines, depress and hold “” glow plug pushbutton for 15 to 20 seconds.

**CAUTION**

Do not start the engine in the high throttle position.





10. Depress and hold “” engine start pushbutton until engine starts, then release. Do not overcrank starter. Release “” choke pushbutton after engine starts (dual fuel).

2.10-4 To Raise or Lower Platform Using Platform Control Console**WARNING**

Be aware of overhead obstructions or other possible hazards around the aerial platform when lifting.

**WARNING**

Do not lower the platform unless the area below is clear of personnel and obstructions.

1. Activate platform control console (refer to Section 2.10-3).
2. On platform control console, select lift/torque/drive switch to “” lift position.
3. Activate and hold “” enable trigger switch.
4. Move controller handle forward “” to raise or backward “” to lower the platform, until desired height is reached.

NOTE

Lowering is not proportional.

Lowering Warning System - A lowering warning system automatically stops the lowering function before reaching the fully retracted position and sounds the alarm. After the operator has released the down controls and taken time to check that no person is near the scissors, the lowering function can be reactivated.

5. Return controller to neutral center position to stop. Release enable trigger switch.

**WARNING**

To protect against unintended movement of the aerial platform, push in the emergency stop button after you have arrived at your desired location or elevation.

NOTE





If the tilt alarm sounds and the platform does not, or only partially raises, immediately lower the platform completely and ensure that the aerial platform is on a firm level surface.

2.10-5 To Drive Forward or Backward**WARNING**

Be aware of blind spots when operating the aerial platform.

**WARNING**



Ensure that there are no personnel or obstructions in the path of travel, including blind spots.

1. Activate platform controls (refer to [Section 2.10-3](#)).
2. On platform control console, select lift/torque/drive switch to “” drive position.
3. Activate and hold “” enable trigger switch.
4. Move controller handle “” forward or “” backward to desired speed and direction of platform travel.
5. Return controller to neutral center position to stop.
Release “” enable trigger switch.

**WARNING**

To protect against unintended movement of the aerial platform, push in the emergency stop button after you have arrived at your desired location or elevation.

2.10-6 To Steer

1. Activate platform controls (refer to [Section 2.10-3](#)).
2. On the platform control console, turn lift/torque/drive switch to “” drive position.
3. Activate and hold “” enable trigger switch.
4. Press “” rocker switch on top of controller handle in either direction to steer.

NOTE

Steering is not proportional. Driving and steering may be active at the same time.

2.10-7 To Select Drive Torque

1. **High Torque:** Select high torque when climbing grades, traveling on rough terrain or when loading or unloading aerial platform. To activate high torque, select lift/torque/drive switch to “” high torque (low speed) position.



WARNING

Aerial platform must be in fully retracted position when operated on any grade. Driving while elevated on any grade may result in death or serious injury.

2. **Low Torque:** Select low torque when traveling on flat surface. To activate low torque, select lift/torque/drive switch to “” low torque (high speed) position.



WARNING

To protect against unintended movement of the aerial platform, push in the emergency stop button after you have arrived at your desired location or elevation.

2.10-8 To Extend or Retract Manual Extension Platform

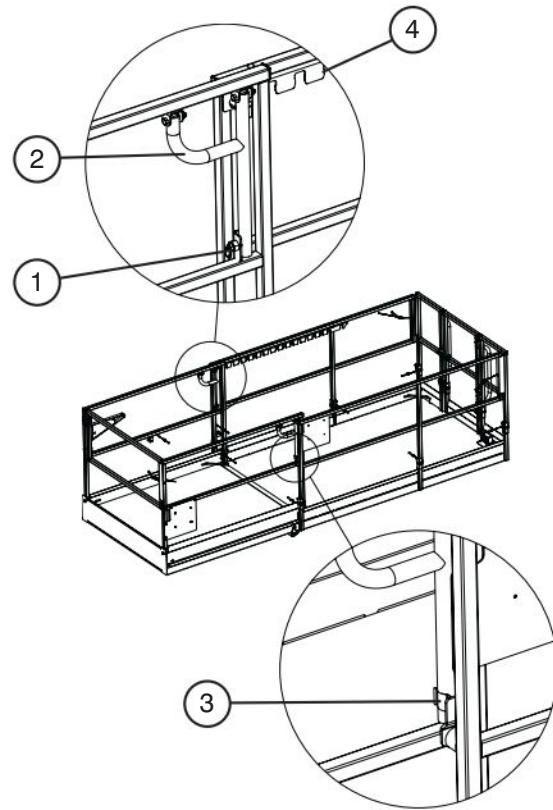

Figure 2-13. Manual Extension Platform

1. To extend/retract manual extension platform, pull out the pull pin (item 1), lift push bars (item 2) up from the gripper clip (item 3) then push/pull the push bar handle until desired extension/retraction is reached.
2. Ensure push bar rests in one of the slots in the extension interval (item 4). Fasten push bar down into the gripper clip and ensure pull pin is locked in place.



2.10-9 Hydraulic Outriggers (If Equipped)

These devices are mounted to four corners of the base. When properly positioned, they increase the stability of the aerial platform.





2.10-9a Before Operation

1. Move around aerial platform to check overhead clearances and ground obstructions.
2. To lower the platform completely, refer to [Section 2.10-4](#). Outrigger controls are not functional when platform is raised.
3. Check that the supporting surface under the tires and outrigger pads is firm and capable of supporting aerial platform and rated load. Do not place outrigger pad on a street drain, manhole cover or other unsupported surface.

2.10-9b To Extend Outriggers

4. On outrigger/generator control console, select and hold “” enable switch to provide power to outrigger circuit.
5. **Auto Extension:** Select auto-level switch to “” extend position until leveling indicator light stops flashing and remains in a solid state. Aerial platform should be completely supported by the outriggers and level at this point.

Manual Extension: Select corresponding outrigger extend/retract switch to “” extend position until platform is fully supported by outriggers and is level. The indicator light flashes while platform is being leveled and remains solid once platform is level. The indicator light has the following states:

-  **Off:** The outriggers are fully retracted.
-  **Flashing Rapidly:** The outriggers are extending but the platform is not level.
-  **Flashing:** The outriggers are extended but the platform is not yet level.
-  **Solid:** The outriggers are extended and the platform is level.

6. Ensure each outrigger pad is in firm contact over its entire surface area, with a suitable supporting surface! Make adjustments if necessary using manual outrigger controls.
7. Operate all non drive functions as described in their respective sections.

NOTE

Each outrigger pad must be in firm contact with the ground for most aerial platform functions to work.

NOTE



Drive functions are disabled if the outriggers are in any position other than fully retracted.



WARNING

If alarm sounds during operation, the aerial platform is not level or an outrigger does not have firm ground contact. Lower the platform immediately! Make the necessary adjustments to level the aerial platform.

2.10-9c To Retract Outriggers

8. On outrigger/generator control console, select and hold “” enable switch to provide power to outrigger circuit.
9. **Auto Retraction:** Select auto-level switch to “” retract position until outriggers are fully retracted.



Manual Retraction: Select corresponding pairs of outrigger extend/retract switches to “” retract position until the outriggers are fully retracted.

NOTE

Limit switches are used to protect outriggers from being damaged. If drive functions are not available, visually check to see that all outriggers are fully retracted.

2.10-10 Generator (If Equipped)

To start generator:

1. On platform control console, select lift/torque/drive switch to “ lift position.
2. On outrigger/generator control console, select generator switch to “ energized position. The engine will automatically switch to low throttle and the generator will start.

To restore normal operation:

3. Flip generator switch to “” off position. The generator will turn off.

NOTE

Activating any lift or outrigger functions, changing key switch settings, activating emergency stop or an engine stall will turn off the generator. The platform may be lowered during generator operation.

2.10-11 Electrical Inverter (If Equipped)

The inverter is operational with alternating current available at all times when the machine is on. The emergency stop button will turn the inverter off.

Checking the status of the inverter

1. Inverter state is indicated by the LEDs on the face of the inverter. A glowing green LED indicates normal operation. If a fault occurs, the status LEDs will indicate the area responsible. Refer to [Section 2.6-2](#).



2.10-12 Shutdown Procedure

1. Completely lower the platform.
2. On platform control console, push in “” emergency stop button.



WARNING

Ensure that you maintain three points of contact when using the ladder to mount/dismount platform.

3. Use the ladder to dismount from platform..
4. Turn platform/engine/base key switch to “” engine position and remove key.
5. Turn main power disconnect switch to “” off position.

2.11 Refueling Procedure

This section provides the operator with the procedure on how to refuel the engine with regular fuel and install the propane cylinder.

IMPORTANT

Before using the aerial platform ensure there is enough fuel to finish the job.



WARNING

Follow all local and national regulations for propane handling.

- Use extreme caution while refueling aerial platforms.
- Ensure engine and all systems are turned off before refueling.
- Refuel aerial platform only in a well ventilated area away from open flame and other sources of ignition, authorized by your employer and supervisor.
- Liquid propane gas fuel is a gas that is heavier than air. It settles in low spots. Any flame or spark could cause a fire that could cause serious injury.
- When changing liquid propane gas cylinder, check all connections for damage or missing parts. Never try to start an aerial platform if you smell gas.
- For gasoline engine models, use only unleaded gasoline with an octane rating 87 or higher.



WARNING

Do not smoke in an area where aerial platforms are stored or refueled.

2.11-1 Regular Fuel

1. Ensure engine and all systems are turned off and emergency stop buttons are depressed.
2. Open fuel compartment door and remove fuel cap.
3. Carefully pour fuel into tank ensuring that no spillage occurs.
4. Securely replace fuel cap.
5. Ensure there are no leaks in the fuel system.
6. Wipe up any spilled fuel.
7. Dispose of rags in an approved container.

Protection of Environment from Chemical Dangers



WARNING

Gasoline, diesel fuel, engine oil and hydraulic fluid are chemicals, which can contaminate the environment. If they are spilled during filling and reach the water, they can cause damage to the environment, e.g., death of fish. For such damage, the party responsible is liable! Therefore, gasoline, diesel fuel, engine oil or hydraulic fluid must not get into the sewage system, streams, rivers or other surface water. For that reason, immediately remove the dripped off or spilled gasoline, diesel fuel, engine oil or hydraulic fluid with appropriate means and dispose of these means according to the regulations.

2.11-2 Propane**WARNING**

Follow all local and federal regulations for propane handling.

Removing a Propane Cylinder

1. Ensure engine and all systems are turned off and emergency stop button is depressed.
2. Turn propane cylinder's main valve clockwise to shut off fuel supply to engine.
3. Start engine and allow it to stop naturally. Restart engine to ensure fuel lines are empty.
4. Disconnect hose from empty propane cylinder by detaching the coupling. Turn fitting counterclockwise.
5. Loosen two propane cylinder straps by pulling up on the metal clips. Disconnect straps from hooks.
6. Remove the propane cylinder.

Installing a Propane Cylinder

1. Ensure engine and all systems are turned off and emergency stop button is depressed.
2. Place propane cylinder on bracket or in compartment.
3. Ensure metal peg on bracket or compartment is inserted into propane cylinder rim.
4. Reconnect propane cylinder straps to hooks and fasten tightly.
5. Attach coupler to propane cylinder and turn clockwise to tighten fitting.
6. Apply soap water or neutral detergent to pipe connection and cylinder.
7. Open valve 1/4 turn counterclockwise and check for any gas leaks.
8. Wipe off soap water or detergent after inspection is completed.
9. Open main valve fully if there are no leaks.

NOTE

The aerial platform is now ready for use by an authorized, qualified operator who has read and completely understands all of [Section 2](#) operations in this manual.

2.12 Loading/Unloading

Know all national, state or territorial/provincial and local rules which apply to your loading/unloading of aerial platforms.

Only qualified personnel shall operate machinery during loading/unloading.

Be sure vehicle capacity and loading equipment hoists, chains, straps, etc., are sufficient to withstand maximum aerial platform weight.

The transport vehicle must be parked on a level surface and must be secured to prevent rolling while aerial platform is being loaded/unloaded.

2.12-1 Lifting

When it is necessary to lift the Skyjack aerial platform the following conditions must be met:

- The platform must be fully lowered.
- The main power disconnect switch must be in “O” off position.
- The hydraulic/fuel and engine compartments must be closed and securely latched.
- The extension platform must be retracted and secured.
- The platform control console must be secured to the railings or removed.
- The platform must be cleared of all personnel, tools and materials.
- The lifting/rigging may be attached to all twelve lifting points as illustrated in [Figure 2-14](#).

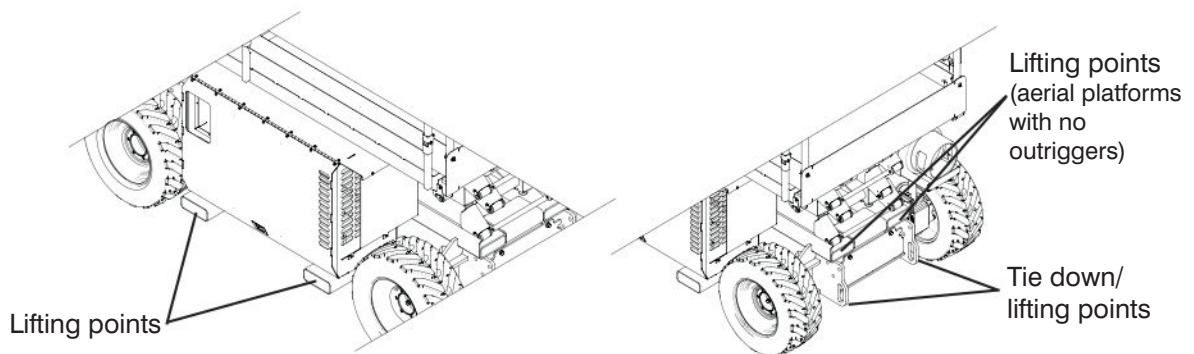

Figure 2-14. Tie Downs/Lifting Points

NOTE

The mass of the aerial platform is as per [Table 2.1](#). The center of gravity is approximately located in the middle of the aerial platform, front to back and side to side, as illustrated in [Figure 2-15](#). Vertically, the center of gravity is approximately just above the base chassis.

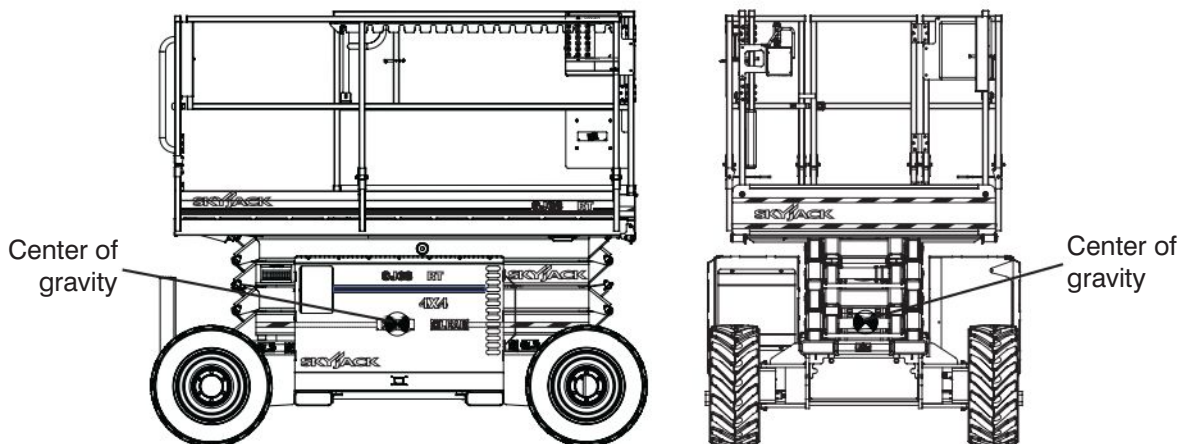

Figure 2-15. Center of Gravity

NOTE

The aerial platform can be lifted with a forklift from the sides but Skyjack does not recommend this use. Lift with forks in designated pockets as illustrated in [Figure 2-16](#).

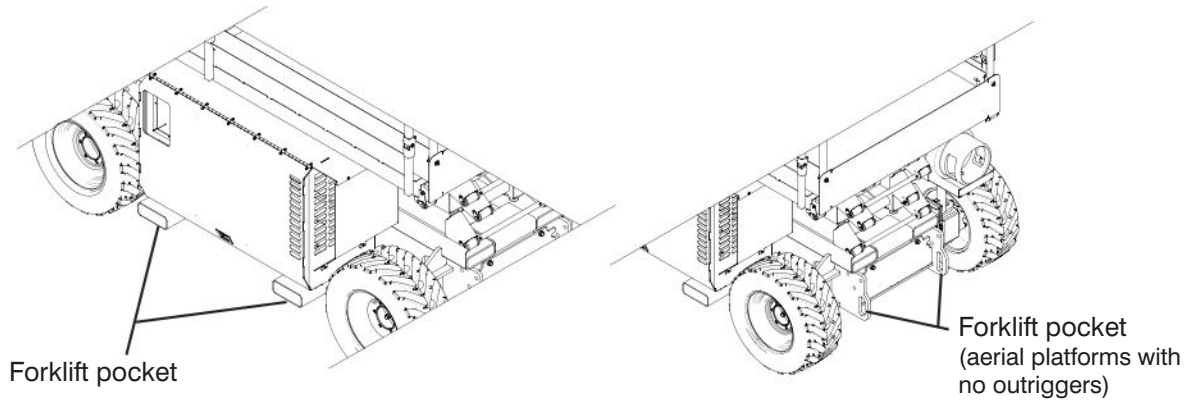

Figure 2-16. Forklift Pockets

2.12-2 Driving

When driving the aerial platform:

- Ramp or dock capacity should be sufficient to withstand maximum aerial platform weight.
- Ramp should be equipped with side guards to prevent inadvertent fall from the ramp.
- Incline should not exceed aerial platform gradeability (refer to [Table 2.2](#)).
- Aerial platform brakes should be checked for proper operation.
- Aerial platform speed should be on high torque setting.

**WARNING**

When transporting, the aerial platform must be secured to the truck or trailer deck. Tie downs are available as illustrated in [Figure 2-14](#).

2.13 Guardrail Folding Procedure

When folded down, the folding guardrail system reduces the height of the retracted aerial platform for transporting only.



WARNING

Any lowered guardrail will create a fall hazard. Remain away from the sides of the platform while raising or lowering the guardrails to avoid falling.

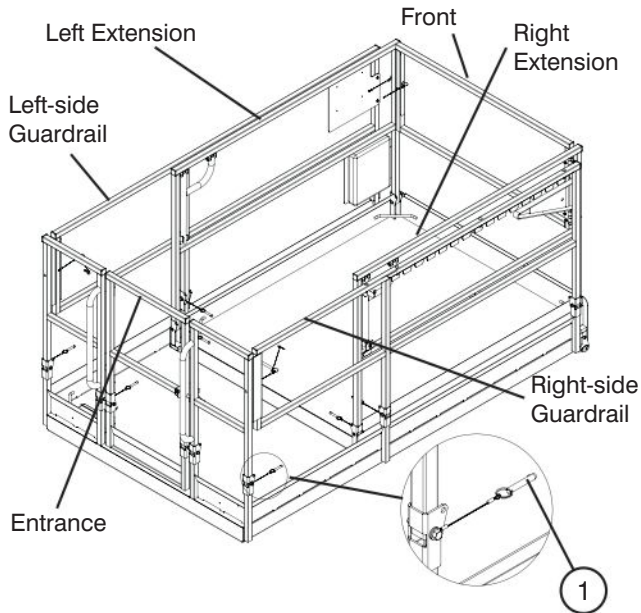

Figure 2-17a. Folding Guardrail System

1. **Guardrail Locking Pin with Lanyard** - This pin is used to lock the guardrail in place.



WARNING

Before operating this aerial platform check the guardrail system for loose or missing locking pins. The guardrail system must be upright and all pins must be locked in place. Death or serious injury could result if the guardrail system is not upright or properly locked.



WARNING

The scissor assembly must be fully lowered before raising or lowering the guardrails.

To fold the guardrail system down:

1. Ensure aerial platform is on level ground.
2. Remove the platform control console and outrigger controls (if equipped) and lay it down on the platform.
3. Turn main power disconnect switch to “O” off position.



WARNING

Ensure that you maintain three points of contact when using the ladder to mount/dismount platform.

4. Use the ladder of aerial platform to access platform.
5. Close the gate.
6. Retract extension platform fully. Refer to [Section 2.10-8](#).



WARNING

Any lowered guardrail will create a fall hazard. Remain away from the sides of the platform while raising or lowering the guardrails to avoid falling.

7. Fold down guardrails in the following order: front, right extension, right-side, left extension, left-side and entrance (refer to [Figure 2-17a](#)).
8. Remove the locking pin that secured the front guardrail to the left extension guardrail then swing it towards the right extension.
9. Remove the locking pin on the right extension guardrail and fold it down with the front guardrail.

10. Remove the locking pins on the right-side guardrail and fold it down.
11. Remove the locking pin on the left extension and fold it down.
12. Remove all the locking pins on the left-side guardrail and fold it down.
13. With the gate closed, remove all the locking pins on the entrance guardrail and fold the guardrail down.

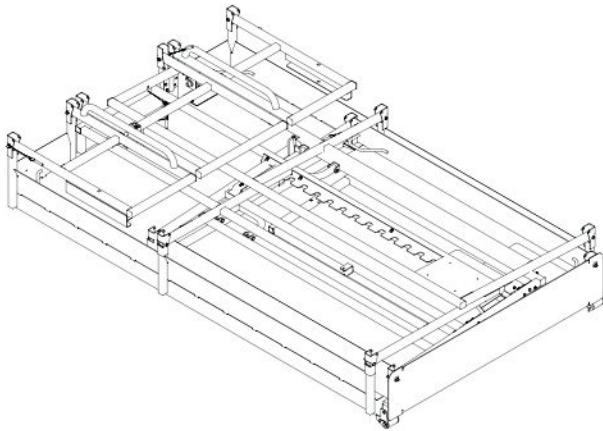

Figure 2-17b. All Guardrails Folded Down

To raise the guardrail system up:



WARNING

The scissor assembly must be fully lowered before raising or lowering the guardrails.

1. Ensure that the aerial platform is on level ground.
2. Turn main power disconnect switch to “○” off position.



WARNING

Ensure that you maintain three points of contact when using the ladder to mount/dismount platform.

3. Use the ladder of aerial platform to access platform.



WARNING

Any lowered guardrail will create a fall hazard. Remain away from the sides of the platform while raising or lowering the guardrails to avoid falling.



WARNING

Ensure that the detent ball of each locking pin is all the way through and each cotter pin fully inserted into the pin hole.

4. Raising the guardrails up is done in the following order: entrance, left side, left extension, right side, right extension and front.
5. Swing up the entrance guardrail then lock it in place by inserting all locking pins.
6. Swing up the left-side guardrail and lock it in place by inserting all locking pins.
7. Swing up the left extension guardrail and lock it in place by inserting the locking pin.
8. Swing up the right-side guardrail and lock it in place by inserting all locking pins.
9. Swing up the right extension guardrail and the front guardrail and lock them in place by inserting the locking pin on the right extension.
10. Swing the front guardrail forward and lock it in place by inserting the locking pin.
11. Mount the platform control console and outrigger controls (if equipped) at the front right of the platform. Lock them in place.



WARNING

Before operating this aerial platform check the guardrail system for loose or missing locking pins. The guardrail system must be upright and all pins must be locked in place. Death or serious injury could result if the guardrail system is not upright or properly locked.

2.14 Moving the Aerial Platform through a Doorway



WARNING

This procedure is suitable for level ground only.

1. Confirm that the height/width of the doorway is sufficient to allow the aerial platform to pass through.

NOTE

If it is necessary to fold the guardrails, refer to [Section 2.13](#) for guardrail folding procedure.



2. Perform a thorough jobsite inspection prior to operating the aerial platform to identify potential hazards in your work area.
3. Cordon-off the pathway which you intend to travel.
4. Position the aerial platform to allow all future motion, including through the doorway, to be in a forward direction.
5. Turn main power disconnect switch to “○” off position.
6. Use the ladder of aerial platform to access platform.



WARNING

Ensure that you maintain three points of contact when using the ladder to mount/dismount platform.

7. Close the gate. On platform control console, push in “●” emergency stop button.
8. Disconnect and remove platform control console from the platform.
9. Fold the guardrails if necessary. Refer to [Section 2.13](#) for guardrail folding procedure.
10. Use the ladder to dismount from platform.
11. Connect platform control console to the connection inside the engine cabinet.

12. Ensure there are no personnel in the intended path of travel.
13. Notify those around the pathway that you will be moving the aerial platform.
14. Use a spotter to guide movement. Ensure the spotter remains at a safe distance.
15. Ensure that the platform control console is properly oriented in the direction the aerial platform is facing.
16. Turn main power disconnect switch to “|” on position.
17. On base control console, pull out “●” emergency stop button.
18. Insert key into platform/engine/base key switch and turn it to “” platform position.
19. On platform control console, pull out “●” emergency stop button.
20. Turn the low/high throttle switch to the “” low throttle position.



CAUTION

Do not start the engine in the high throttle position.

21. Start engine.



DANGER

Do not drive the aerial platform toward yourself.

22. On platform control console, select lift/torque/drive switch to “” low speed drive position.
23. Using as low a speed as practical and the operator positioned behind the aerial platform, drive forward through doorway.
24. Once safely through doorway, push in “●” emergency stop button and turn main power disconnect switch to “○” off position.

25. Disconnect platform control console and return it to the platform.

**WARNING**

Ensure that you maintain three points of contact when using the ladder to mount/dismount platform.

26. Return guardrails to upright position if folded. Refer to [Section 2.13](#) for guardrail folding procedure.

**WARNING**

Before operating this aerial platform check the guardrail system for loose or missing locking pins. The guardrail system must be upright and all pins must be locked in place.

Death or serious injury could result if the guardrail system is not upright or properly locked.

27. Once platform control console is securely reconnected and guardrails up, normal operation may continue.

2.15 Winching and Towing Procedure

This section provides the operator with procedure about winching and towing and how to release the brakes.



WARNING

Ensure platform is fully lowered before winching or towing. Sudden motion could cause the aerial platform to become unstable. Death or serious injury could result.



WARNING

In emergency situations where aerial platform functions are not available and lowering is impeded by an obstacle, utmost care must be taken to move aerial platform far enough to clear obstacle. In such cases, operation must be extremely smooth with no sudden movements and must not exceed a speed of 50 mm/sec.



WARNING

When pushing, winching or towing, do not exceed 3.2 km/h.



WARNING

Do not push, winch or tow aerial platform onto a slope, or brake the towing vehicle rapidly. Do not pull aerial platform down an incline towards a winch.

2.15-1 To Release the Free-wheeling Valve

1. Ensure aerial platform is on level ground. Chock or block the wheels to prevent aerial platform from rolling.



Figure 2-18. Free-Wheeling Valve

2. **Free-wheeling Valve** - Turning the valve knob counterclockwise (item 1) to a fully opened position allows fluid to flow through the wheel motors, thus providing “free-wheeling”.



WARNING

The free-wheeling valve must be closed tightly (clockwise) for normal operation.

2.15-2 To Release the Brakes Manually**WARNING**

Do not manually disengage brakes if the aerial platform is on a slope.



Figure 2-19. Disc Brakes System

NOTE

Brakes must be manually disengaged for pushing, winching or towing.

1. Ensure aerial platform is on level ground. Chock or block wheels to prevent aerial platform from rolling.
 2. Turn main power disconnect switch to “○” off position.
 3. Locate brake auto reset valve plunger (item 1) and brake hand pump (item 2) at the main manifold in the hydraulic/fuel compartment.
 4. Push in brake auto reset valve plunger.
 5. Grasp brake hand pump and rapidly depress until firm resistance is felt. The brakes are now released.
 6. Remove wheel chocks or blocks, then push, winch or tow aerial platform to desired location.
8. Chock or block wheels to prevent aerial platform from rolling.
 9. Reengage brakes by pulling out brake auto reset valve plunger.

**WARNING**

Brakes must be reengaged immediately after reaching the desired location.

7. Position aerial platform on a firm and level surface.

2.16 Emergency Lowering Procedure

This section guides the operator on how to use emergency lowering system. This system allows platform lowering in the event of an emergency or an engine malfunction.



WARNING

Keep clear of scissors mechanism when using emergency lowering valve.

1. Remove any obstructions from a lowering platform.
2. Extension platform(s) may need to be retracted or aerial platform may need to be moved to clear obstruction. Refer to [Section 2.15](#) for winching and towing procedures.

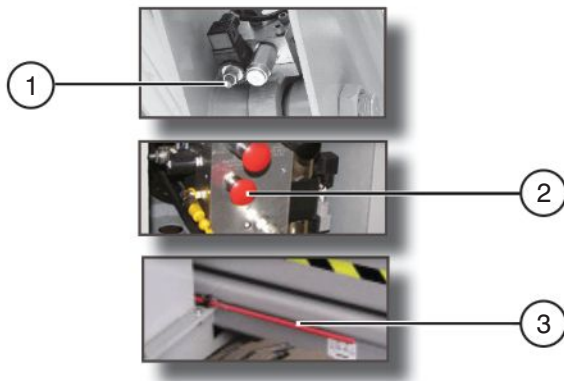

Figure 2-20. Emergency Lowering System

3. Locate holding valve override knob (item 1) at base of each lift cylinder. Depress and turn counterclockwise (1/4 turn). If necessary, use emergency lowering access rod (item 3) located on aerial platform base.
4. On the hydraulic/fuel compartment, pull out and hold emergency lowering pull valve (item 2) to lower platform.
5. To restore normal operation, depress and turn the holding valve override knobs clockwise.

2.17 Maintenance Support Procedure

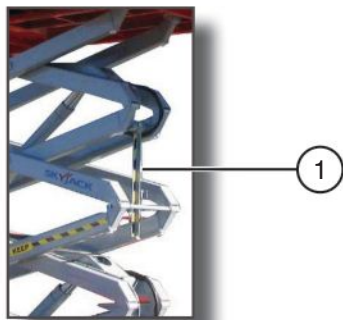

Figure 2-21. Maintenance Support

1. **Maintenance Support** - The maintenance support is a safety mechanism designed to support the scissor assembly. When properly positioned it can support the scissor assembly and empty platform. The maintenance support must be used when inspection and/or maintenance is to be performed within the lifting mechanism.



WARNING

The maintenance support must be used when inspection and/or maintenance or repairs are to be performed within the lifting mechanism. Failure to use this safety mechanism could result in death or serious injury.

Proper Use of Maintenance Support

1. Remove all material from platform.
2. Raise platform until there is adequate clearance to swing down maintenance support.
3. Swing maintenance support down from storage bracket into a vertical position.
4. Remove hands and arms from scissors area.
5. Lower platform until bottom end of maintenance support contacts the labeled cross bar and scissors are supported by maintenance support.
6. Turn main power disconnect switch to “○” off position.

To Store the Maintenance Support

1. Turn main power disconnect switch to “|” on position.
2. Raise platform until there is adequate clearance to swing up the maintenance support.
3. Swing bar up into storage bracket.
4. Lower the platform.



WARNING

Do not reach through the scissor assembly when the platform is raised without the maintenance support properly positioned. Failure to avoid this hazard could result in death or serious injury.

Table 2.1 Standard and Optional Features

MODEL	Compact RT's	
	6826	6832
STANDARD EQUIPMENT		
Joystick control	*	*
4WD	*	*
18.5 kW (24.8 hp) Kubota D902 diesel water-cooled engine	*	*
Easy operation 152 cm roll out extension platform	*	*
Load sensing system	*	*
Lowering warning system	*	*
Tilt sensing system	*	*
Scissor guards	*	*
Swing out engine tray	*	*
Multiple wet disc-spring applied hydraulic release brakes	*	*
Manual brake release	*	*
Wiring for AC outlet	*	*
Tilt alarm with drive/lift cutout	*	*
Lanyard attachment points	*	*
Hinged railing system	*	*
Operator horn	*	*
Spring loaded full height gate at rear	*	*
Forklift pockets, tie down/lifting lugs	*	*
Foam filled low profile grip lug tires	*	*
Hourmeter	*	*
Color coded and numbered wiring system	*	*
Hydraulic oil level indicators	*	*
Base controls	*	*
All motion audible alarm	*	*
OPTIONAL EQUIPMENT		
Flashing light	*	*
23.1 kW (31 hp) Kubota DF972 dual fuel - gasoline/propane engine	*	*
Shop air line to platform	*	*
Work lights	*	*
Independent leveling hydraulic outriggers	*	*
800W Inverter	*	*

60436AE-CE

Table 2.2 Specifications and Features

Model		Compact RT's			
		6826		6832	
Weight*	No Outriggers	2925 kg	6475 lb.	3500 kg	7725 lb.
	With Outriggers	3330 kg	7375 lb.	3680 kg	8125 lb.
Width		1.73 m	68 in.	1.73 m	68 in.
Length	No Outriggers	2.72 m	107 in.	2.72 m	107 in.
	With Outriggers	3.35 m	132 in.	3.35 m	132 in.
Platform Size		1.4 m x 2.4 m	56 in. x 96 in.	1.4 m x 2.4 m	56 in. x 96 in.
Height	Working	9.8 m	32 ft.	11.7 m	38 ft.
	Platform Elevated	8.0 m	26 ft.	9.8 m	32 ft.
	Platform Lowered	2.37 m	7.8 ft.	2.51 m	8.25 ft.
	Drive	8.0 m	26 ft.	9.8 m	32 ft.
Speed	Normal Drive	6.3 km/h	4 mph	6.3 km/h	4 mph
	Elevated Drive	0.63 km/h	0.39 mph	0.63 km/h	0.39 mph
	Lift (Rated Load)	36 sec		39 sec	
	Lower (Rated Load)	36 sec		36 sec	
Engine (RPM)	Kubota Diesel	3500 (High Throttle) / 2050 (Low Throttle)			
	Kubota Dual Fuel	3500 (High Throttle) / 2050 (Low Throttle)			
Tires	Foam-filled	OTR Outrigger - 26 x 12			
	Air-filled	N/A			
Sound Pressure		96 dB(A)			
Gradeability (Torque Equivalent To)		50%		40%	

60440AH-CE

* Weights are approximate; refer to serial nameplate for specific weight.

Table 2.3 Owner’s Annual Inspection Record

Model Number: _____		Serial Number: _____							
Recording Date									
Recording Year #	1	2	3	4	5	6	7	8	9
Owner’s Name									
Inspected By									

604141AB

As described earlier in this section, this decal is located on the scissor assembly. It must be completed after an annual inspection has been completed. Do not use the aerial platform if an inspection has not been recorded in the last 13 months.

Table 2.4 Maximum Platform Capacities (Evenly Distributed)

MODEL		Total		Extension	
		Capacity	Number of Occupants	Capacity	Number of Occupants
6826	One Extension Platform	567 kg	4	136 kg	1
6832	One Extension Platform	454 kg	2	136 kg	1

60441AB-CE

NOTE: Occupants and materials are not to exceed rated load.
Refer to capacity label for additional information and for models equipped with options.

BEAUFORT SCALE	Wind Speed				Ground Conditions
	m/s	km/h	ft/s	mph	
3	3.4 – 5.4	12.5 – 19.4	11.5 – 17.75	5 – 12.0	Papers and thin branches move, flags wave
4	5.4 – 8.0	19.4 – 28.8	17.75 – 26.25	12.0 – 18	Dust is raised, paper whirled up, and small branches sway.
5	8.0 – 10.8	28.8 – 38.9	26.25 – 35.5	18 – 24.25	Shrubs with leaves start swaying. Wave crests are apparent in ponds or swamps.
6	10.8 – 13.9	38.9 – 50.0	35.5 – 45.5	24.5 – 31	Tree branches move. Power lines whistle. It is difficult to open an umbrella.
7	13.9 – 17.2	50.0 – 61.9	45.5 – 65.5	31 – 38.5	Whole trees sway. It is difficult to walk against the wind.

60338AC

Table 2.5 Floor Loading Pressure

MODEL		Total Aerial Platform Weight		Total Aerial Platform Load					
				Wheel		LCP**		OUP**	
		kg	lb.	kg	lb.	kPa	psi	kg/m ²	psf
6826	min*	2903	6400	1161	2560	1085	157.4	1007	206
	max*	3960	8730	1584	3492	1209	175.41	1373	281
6832	min*	3475	7661	1390	3064	1142	165.59	1205	247
	max*	4189	9235	1635	3605	1250	181.36	1452	297

60442AE-CE

* **min** - Total aerial platform weight with no options

max - Aerial platform weight + all options + full capacity

** **LCP – Locally Concentrated Pressure** is a measure of how hard the aerial platform presses on the areas in direct contact with the floor. The floor covering (tile, carpet, etc.) must be able to withstand more than the indicated values above.

OUP – Overall Uniform Pressure is a measure of the average load the aerial platform imparts on the whole surface directly underneath it. The structure of the operating surface (beams, etc.) must be able to withstand more than the indicated values above.

NOTE:

The **LCP** or **OUP** that an individual surface can withstand varies from structure to structure and is generally determined by the engineer or architect for that particular structure.

Floor Loading Pressure

Locally Concentrated Pressure (LCP):

$$\begin{aligned} \text{Foot Print Area} &= \text{Length} \times \text{Width} \\ &= \pi r^2 \end{aligned}$$

$$\text{LCP} = \frac{\text{Weight of Aerial Platform} + \text{Capacity}}{\text{Foot Print Area} \times 4 \text{ (Tires)}}$$

Overall Uniform Pressure (OUP):

$$\text{Base Area} = \text{Length} \times \text{Width}$$

$$\text{OUP} = \frac{\text{Weight of Aerial Platform} + \text{Capacity}}{\text{Base Area}}$$

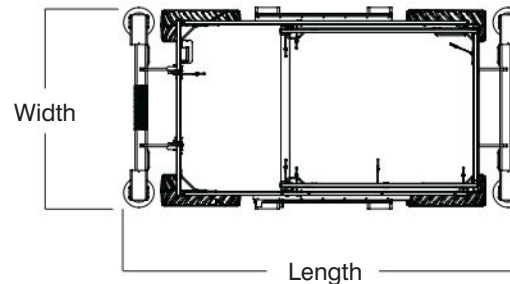
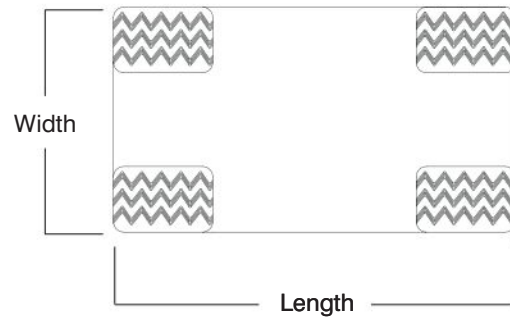
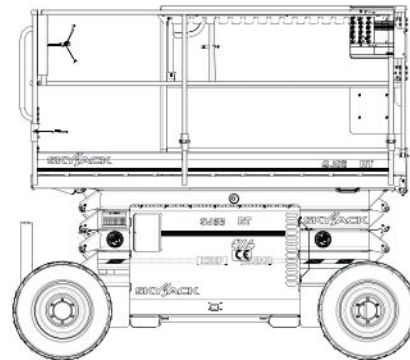
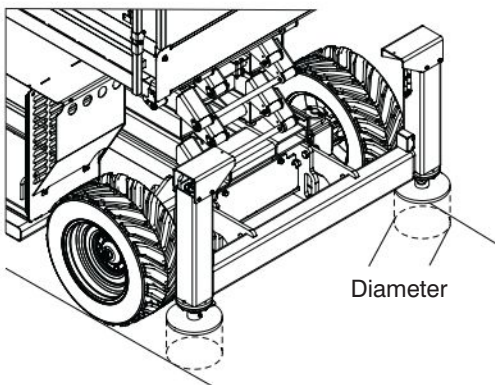
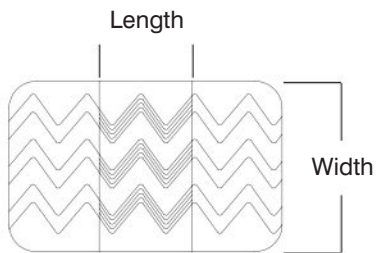
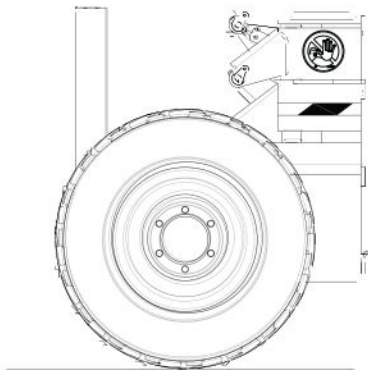

! WARNING

Intermixing tires of different types or using tires of types other than those originally supplied with this equipment can adversely affect stability. Therefore, replace tires only with the exact original Skyjack-approved type. Failure to operate with matched approved tires in good condition may result in death or serious injury.

Table 2.6 EC Declaration of Conformity

EC Declaration of Conformity

We, SKYJACK INC., [*], declare under our sole responsibility that the product Scissor Type Elevating Work Platform

Model number: [*]

Serial number: [*]

To which this declaration relates is in conformity with the following directives:

Machinery Directive 98/37/EC

Notified body is: [*]

EC type Examination Certificate No: [*]

Machinery Directive 98/37/EC as related to Load Sensing System

Notified body is: [*]

EEC Type Examination Certificate No: [*]

EMC Directive 89/336/EEC

Certified laboratory: [*]

The Technical Construction File is maintained at:

[*]

The authorized representative located within the community is:

[*]

Place of issue:

[*]

Note: In case of unauthorized modification, this Declaration becomes invalid.

Test Engineer:

Quality Coordinator:

[*] For information refer to the English EC Declaration of Conformity provided with your aerial platform.

General Maintenance

Before attempting any repair work, disconnect battery by turning main power disconnect switch to “○” off position. Preventive maintenance is the easiest and least expensive type of maintenance.

Table 2.7 Maintenance and Inspection Schedule

Frequency	Daily	3 months or 150 hours	Yearly	Frequency	Daily	3 months or 150 hours	Yearly
Visual and Daily Maintenance Inspections				Lifting Mechanism			
Labels	A			Maintenance Support	A		
Electrical	A			Scissor Assembly	A		
Limit Switches	A			Scissor Bumpers	A		
Hydraulic	A			Rollers	A		
Engine Compartment				Lift Cylinder(s)	A		
Main Power Disconnect Switch	A			Scissor Guards	A		
Base Control Switches	A			Base			
Load/Tilt Sensor	A			Base Weldment	A		
Battery	A			Wheel/Tire Assembly	A		
Hydraulic Pump	A			Steer Cylinder Assembly	A		
Radiator	A			Splitter Manifold	A		
Muffler and Exhaust	A			Tie Rod	A		
Engine Pivot Tray	A			Emergency Lowering Access Rod	A		
Engine Oil Level	A			Ladder	A		
Fuel Shut-off Valve	A			Outriggers	A		
Engine Air Filter	A			Function Tests			
Fuel Leaks	A			Test Main Power Disconnect Switch	A		
Hydraulic/Fuel Compartment				Base Control Console			
Hydraulic Tank	A			Test Platform/Engine/Base Key Switch	A		
Hydraulic Oil	A			Test Emergency Stop	A		
Hydraulic Return Filter	A			Test Platform Raise/Lower Switch	A		
Fuel Tank	A			Test Emergency Lowering	A		
Fuel Leaks	A			Test Free-wheeling	A		
Main Manifold	A			Platform Control Console			
Gear Type Flow Divider	A			Test Emergency Stop	A		
Platform Assembly				Test Enable Trigger Switch	A		
Lanyard Attachment Anchors	A			Test Platform Raising/Lowering	A		
AC Outlet on Platform	A			Test Lowering Warning	A		
Manuals	A			Test Steering	A		
Platform Control Console	A			Test Driving	A		
				Test Speed Limit	A		
				Test Brakes	A		
				Test Horn	A		

B*†

B*†

B*†

60601AC-CE

A - Perform Visual and Daily Maintenance Inspections & Functions Test. Refer to Section 2.8 and Section 2.9 of this manual.

B - Perform Scheduled Maintenance Inspection. Refer to Service & Maintenance manual.

* - Maintenance must be performed only by trained and competent personnel who are familiar with mechanical procedures.

† - Refer to Skyjack's website @ www.skyjack.com for latest service bulletins prior to performing quarterly or yearly inspection.



WARNING

Use original or manufacturer-approved parts and components for aerial platform.

Table 2.8 Operator's Checklist



Serial Number: _____
 Model: _____
 Hourmeter Reading: _____
 Date: _____
 Time: _____

Operator's Name (Printed): _____

Operator's Signature: _____

Each item shall be inspected using the appropriate section of the Skyjack operating manual. As each item is inspected, check the appropriate box.

- P** - PASS
- F** - FAIL
- R** - REPAIRED
- NA** - NOT APPLICABLE

- DAILY
- FREQUENTLY
- ANNUALLY
- BI-ANNUALLY

	N/A	P	F	R
Visual and Daily Maintenance Inspections				
Labels				
Electrical				
Limit Switches				
Hydraulic				
Engine Compartment				
Main Power Disconnect Switch				
Base Control Switches				
Load/Tilt Sensor				
Battery				
Hydraulic Pump				
Radiator				
Muffler and Exhaust				
Engine Pivot Tray				
Engine Oil Level				
Fuel Shut-off Valve				
Engine Air Filter				
Fuel Leaks				
Hydraulic/Fuel Compartment				
Hydraulic Tank				
Hydraulic Oil				
Hydraulic Return Filter				
Fuel Tank				
Fuel Leaks				
Main Manifold				
Gear Type Flow Divider				
Platform Assembly				
Lanyard Attachment Anchors				
AC Outlet on Platform				
Manuals				
Platform Control Console				

	N/A	P	F	R
Lifting Mechanism				
Maintenance Support				
Scissor Assembly				
Scissor Bumpers				
Rollers				
Lift Cylinder(s)				
Scissor Guards				
Base				
Base Weldment				
Wheel/Tire Assembly				
Steer Cylinder Assembly				
Splitter Manifold				
Tie Rod				
Emergency Lowering Access Rod				
Ladder				
Outriggers				
Function Tests				
Test Main Power Disconnect Switch				
Base Control Console				
Test Platform/Engine/Base Key Switch				
Test Emergency Stop				
Test Platform Raise/Lower Switch				
Test Emergency Lowering				
Test Free-wheeling				
Platform Control Console				
Test Emergency Stop				
Test Enable Trigger Switch				
Test Platform Raising/Lowering				
Test Lowering Warning				
Test Steering				
Test Driving				
Test Speed Limit				
Test Brakes				
Test Horn				





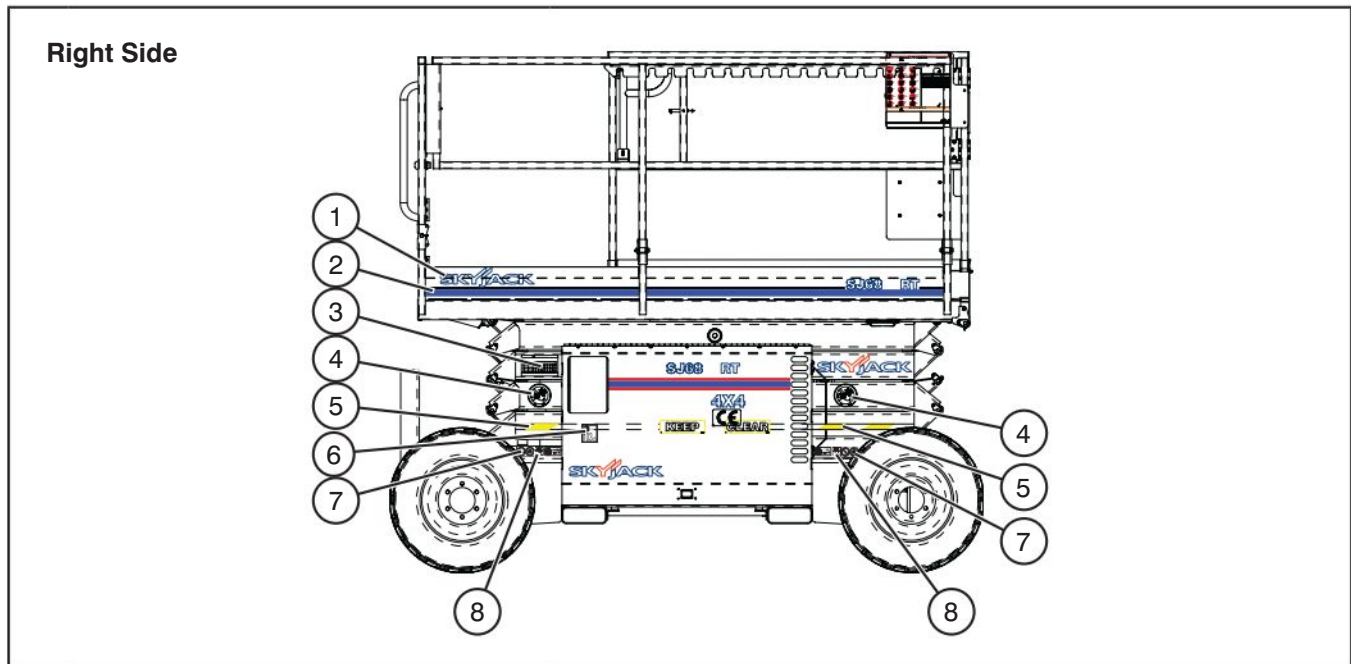

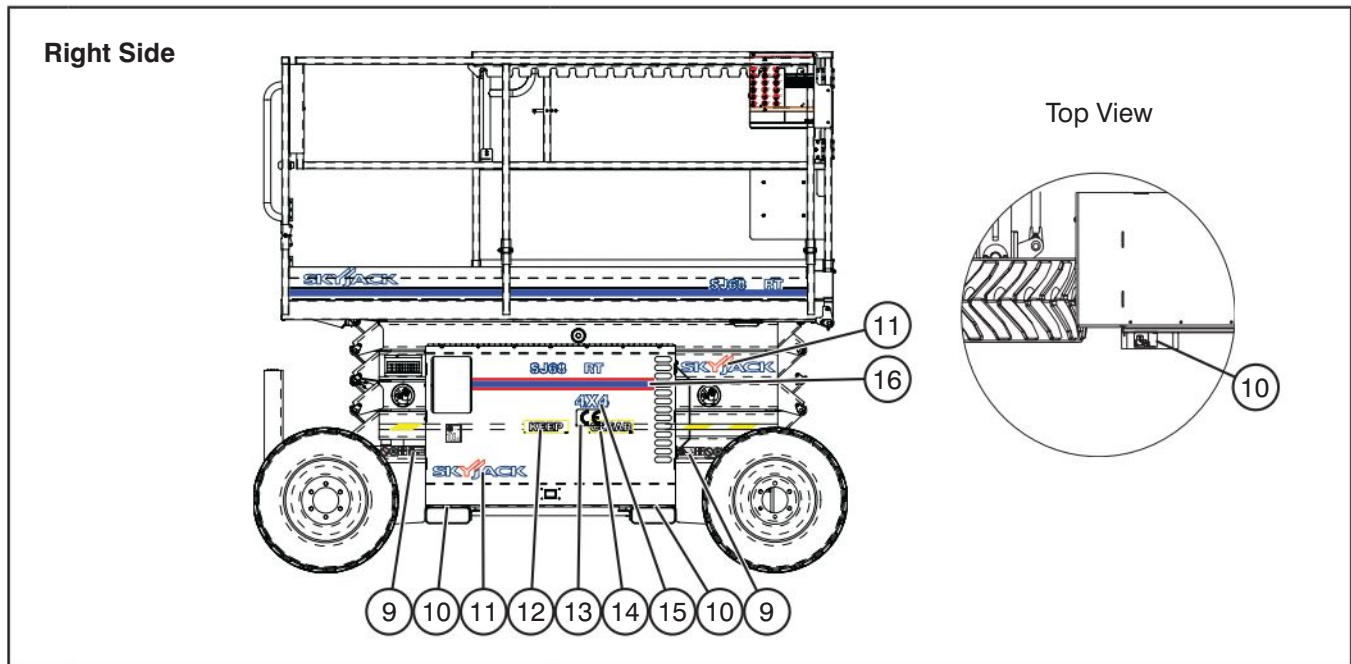

Note:
 Make a copy of this page or visit the Skyjack web site:
www.skyjack.com for a printable copy.

60602AB-CE





No.	Label Pictorial	Description
1		Skyjack Logo Small Skyjack logo - blue
2		Tape - Blue/White Skyjack pinstripe
3		Annual Inspection Ensure that work platform has received annual inspection prior to operation.
4		Keep Clear (Pictorial) Keep clear.
5		Caution Tape Stripe Caution stripe
6		Sound Power Level Guaranteed maximum sound power level
7		Foam-filled Tire Indicates foam-filled tire only.
8		Wheel Load 1635 kg/3600 lb. Indicates rated wheel load.



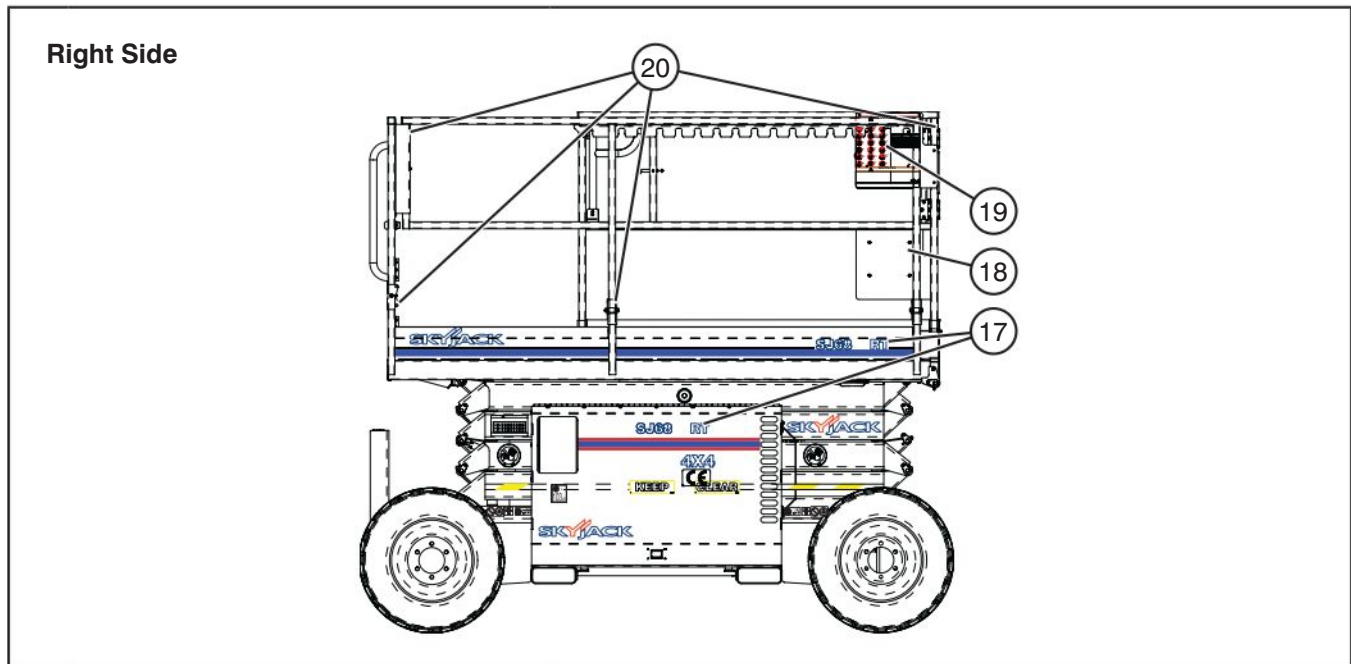







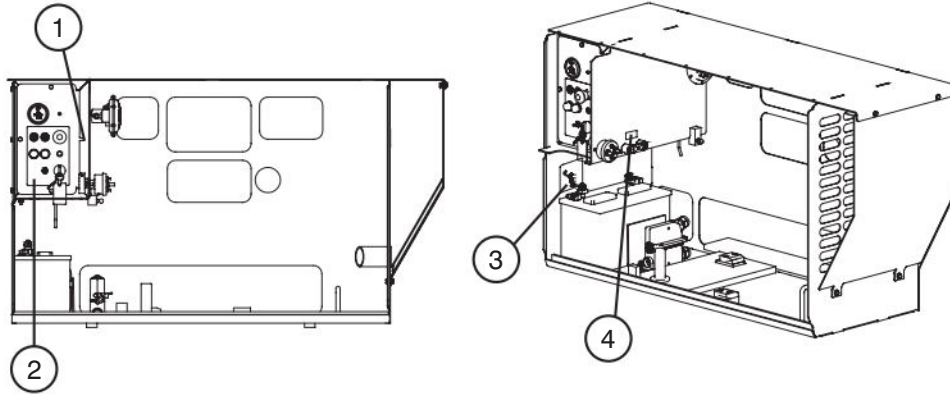



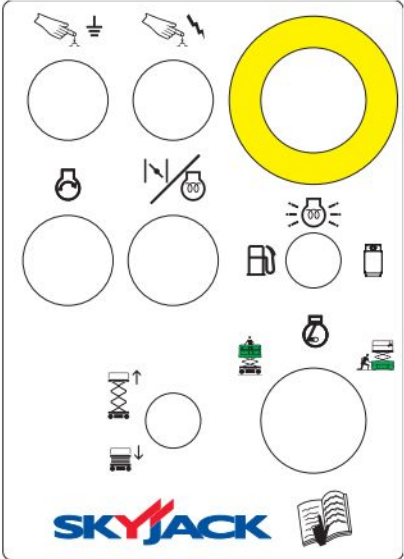





No.	Label Pictorial	Description
9		<p>Wheel Specifications</p> <p>Refer to manual for wheel type, offset, pressure and torque.</p>
10		<p>Forklift Pocket</p> <p>Insert fork fully into pocket to lift aerial platform.</p>
11		<p>Skyjack Logo</p> <p>Small Skyjack logo - blue and red</p>
12		<p>“Keep”</p> <p>Keep clear.</p>
13		<p>“CE”</p> <p>CE rating mark</p>
14		<p>“Clear”</p> <p>Keep clear.</p>
15		<p>4x4</p> <p>Product identifier - 4 wheel drive</p>
16		<p>Tape - Red/Blue/Red</p> <p>Skyjack pinstripe</p>



No.	Label Pictorial	Description
17	<p style="text-align: center;">SJ6826RT</p> <hr/> <p style="text-align: center;">SJ6832RT</p>	<p>Model Number*</p> <p>Product Identifier *Model number will vary, may not be as shown.</p>
18		<p>Manual Storage Box</p> <p>Indicates location of operating manual.</p>
19		<p>Hazard Identification</p> <p>Read and understand the outlined risks associated with this work platform prior to operation.</p>
20		<p>Railing Pins (Vertical)</p> <p>WARNING! Falling Hazard. Ensure hinged railing is pinned.</p>

Engine Panel





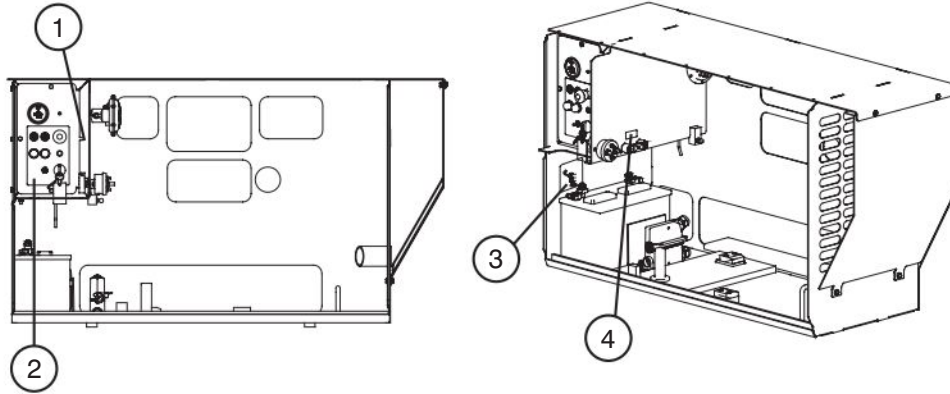

No.	Label Pictorial	Description
1		<p>Main Power Disconnect</p> <p>Main power disconnect switch</p>
2		<p>Electrical Panel SJ68xxRT</p> <p>Push “” to reset ground circuit breaker.</p> <p>Push “” to reset power circuit breaker.</p> <p>Push “” to stop engine and disable controls (Emergency Stop).</p> <p>Light indicates controls enabled.</p> <p>Push and hold “” to start engine.</p> <p>Push and hold “” to operate choke (dual fuel) or “” glow plugs (diesel).</p> <p>Select “” gasoline or “” propane. Light “” indicates glow plug operation (diesel).</p> <p>Select “” to raise or “” to lower platform.</p> <p>Select “” to enable platform controls, “” to allow engine run with no controls active or “” to enable base control console.</p> <p>Read operating manual. </p>

Engine Panel

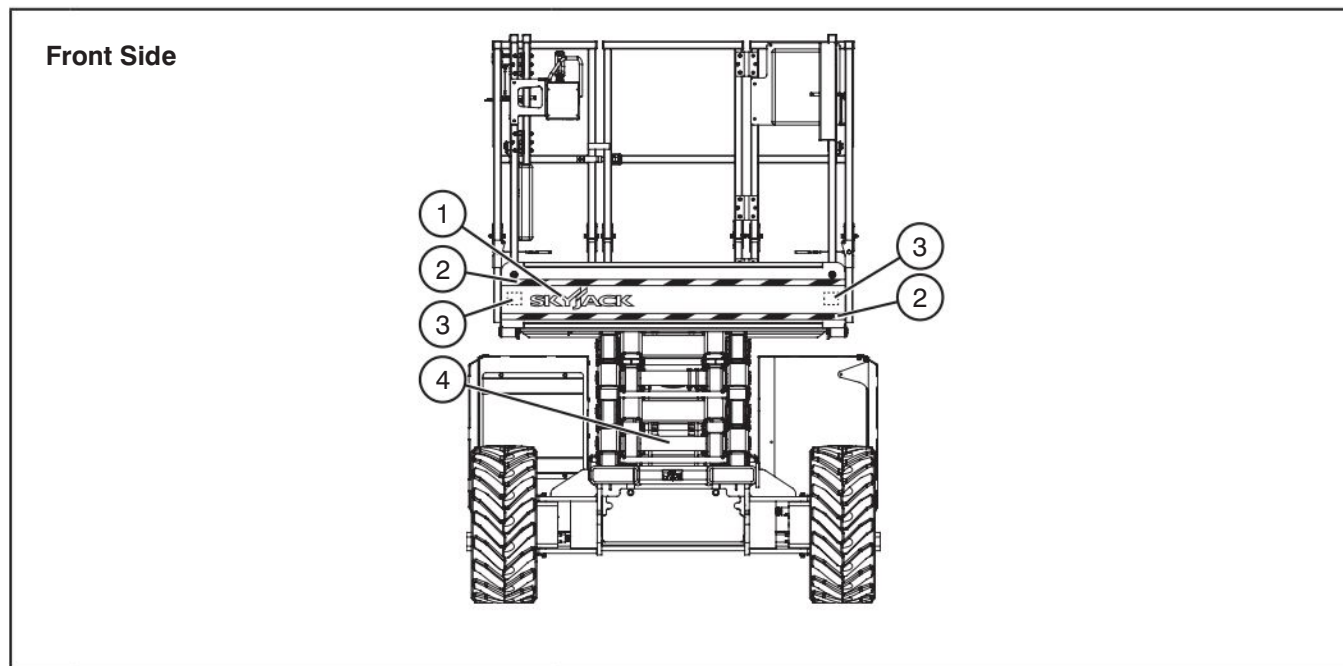



No.	Label Pictorial	Description
3		<p>Battery Fuse Assembly</p> <p>Assemble fuse as shown. Torque to value indicated.</p>
4		<p>Fuse</p> <p>Fuse location</p>

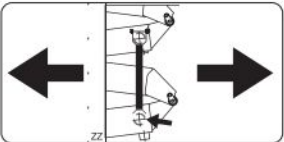

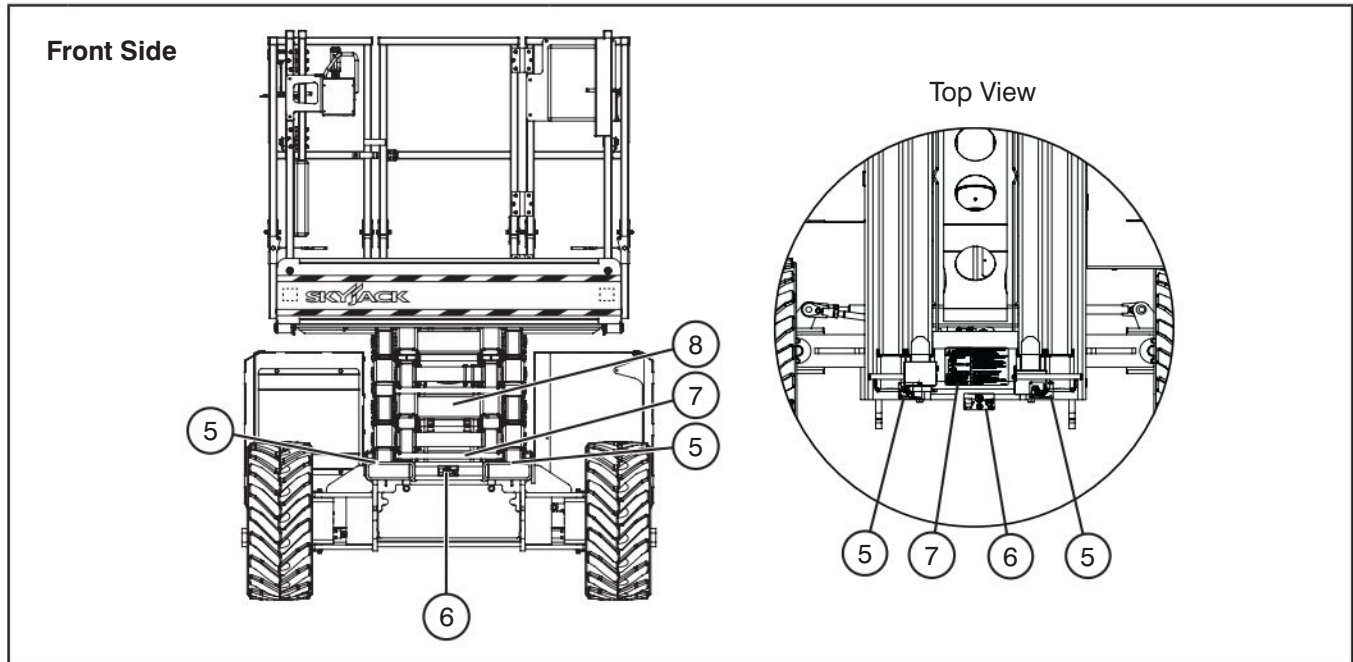
No.	Label Pictorial	Description
1		<p>Skyjack Logo</p> <p>Small Skyjack logo - blue</p>
2		<p>Caution Tape Stripe</p> <p>Caution stripe</p>
3		<p>Harness Anchorage</p> <p>Anchor safety belt/harness tethers here.</p>
4		<p>Maintenance Support</p> <p>Deploy maintenance support here.</p>

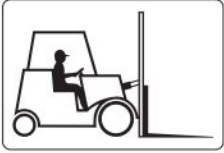

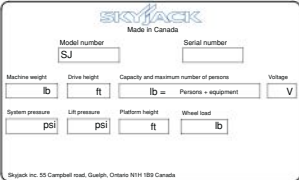

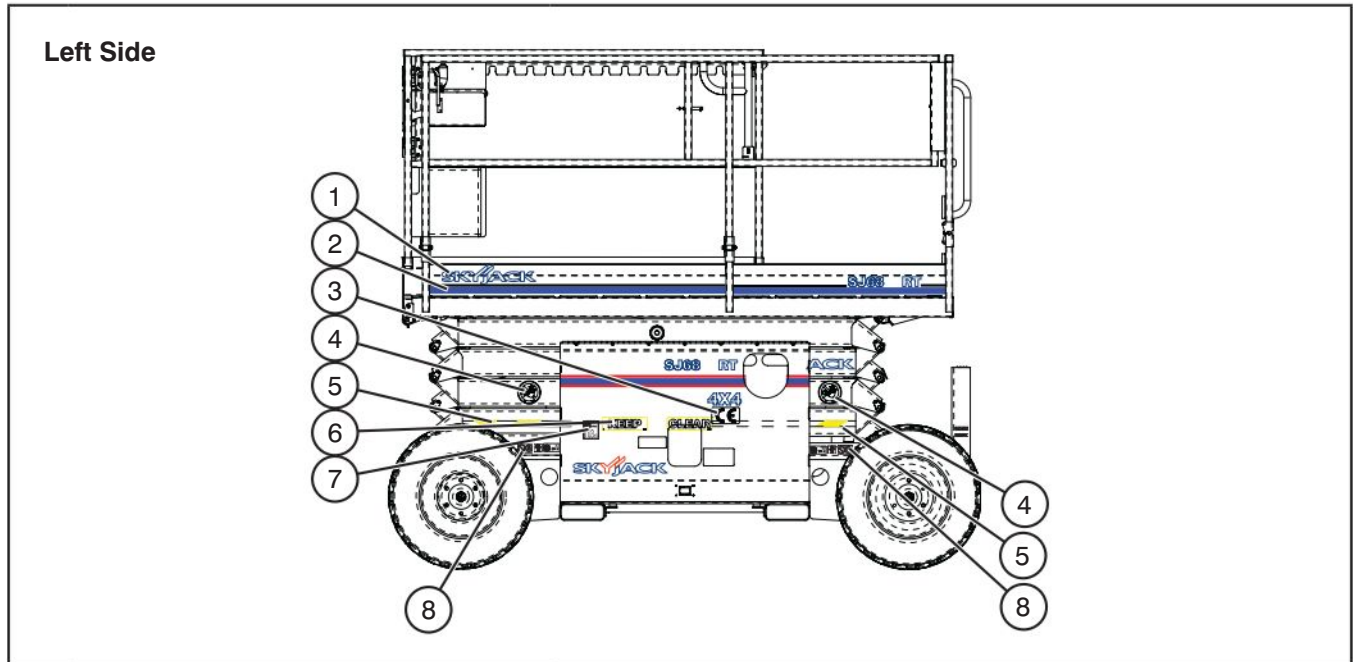

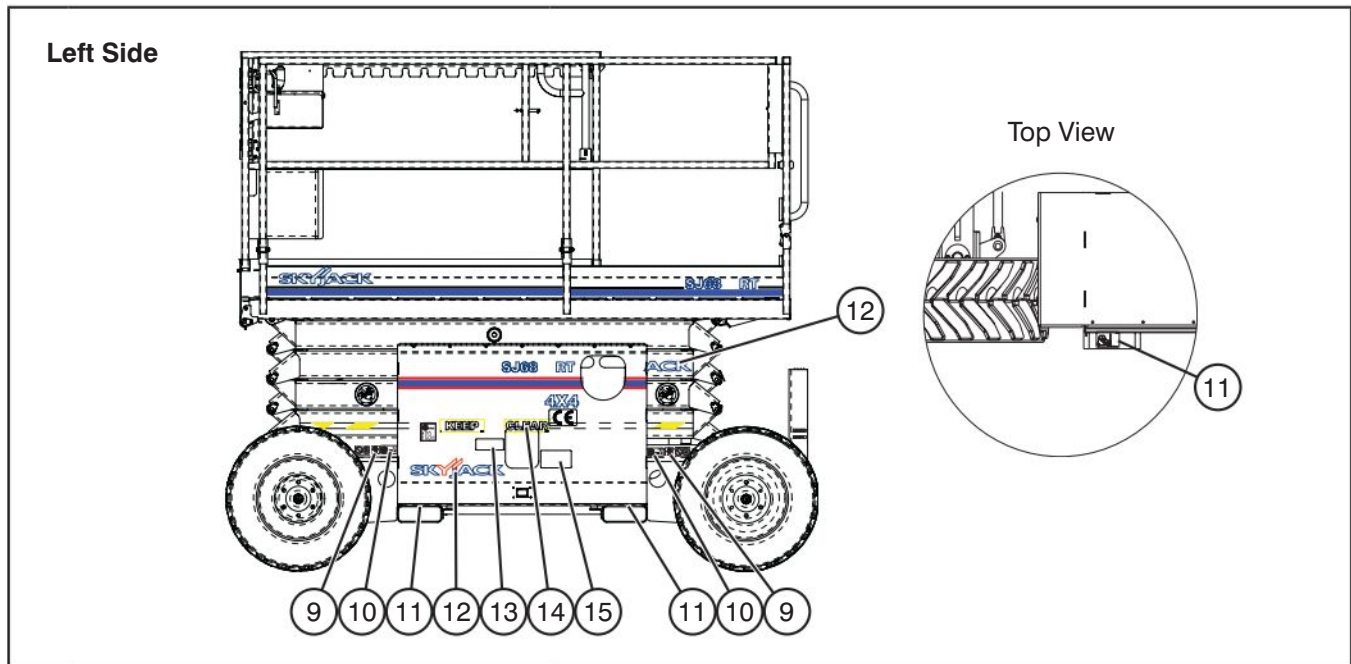

No.	Label Pictorial	Description
5		<p>Forklift Pocket</p> <p>Insert fork fully into pocket to lift aerial platform.</p>
6		<p>Lift and Tie Down Points</p> <p>Only use these points for lifting or tying down.</p>
7		<p>Maintenance Support</p> <p>Instructions on use of maintenance support</p>
8		<p>Serial Plate</p> <p>Product identification and specifications</p>





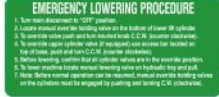

No.	Label Pictorial	Description
1		Skyjack Logo Small Skyjack logo - blue
2		Tape - Blue/White Skyjack pinstripe
3		"CE" CE rating mark
4		Keep Clear (Pictorial) Keep clear.
5		Caution Tape Stripe Caution stripe
6		"Keep" Keep clear.
7		Sound Power Level Guaranteed maximum sound power level
8		Foam-filled Tire Indicates foam-filled tire only.

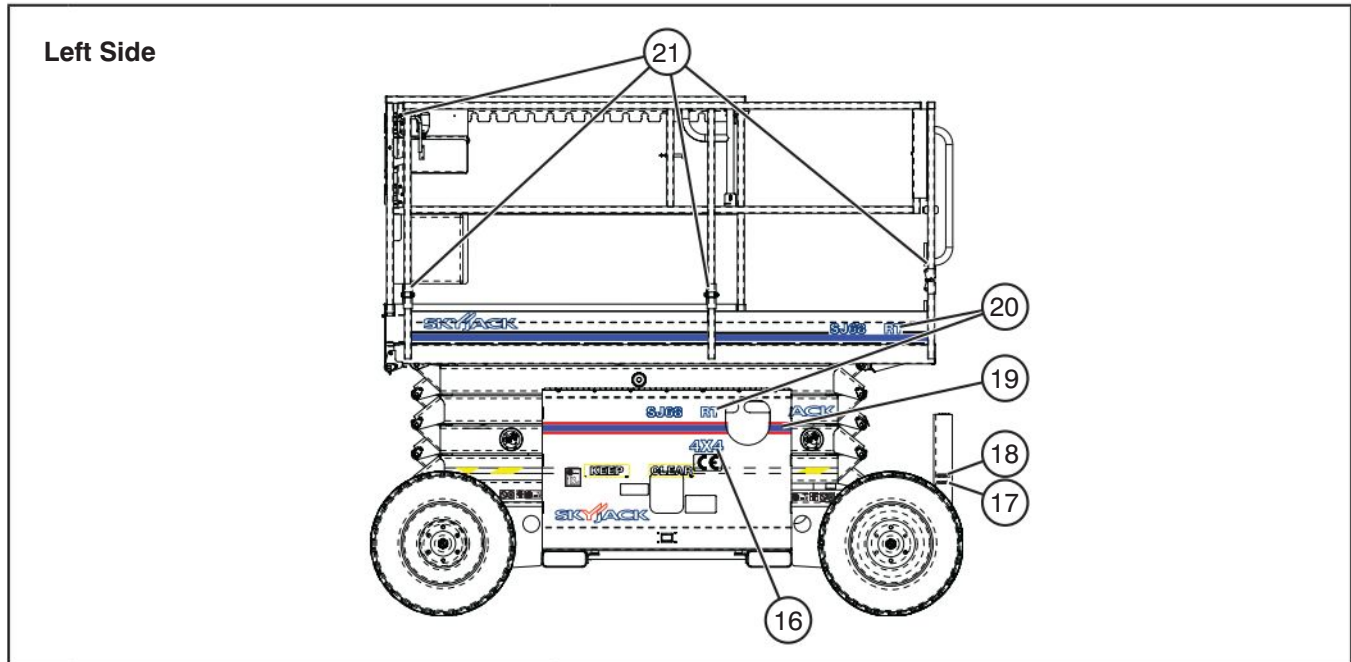

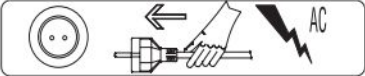

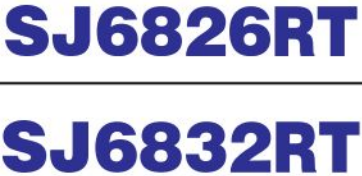

No.	Label Pictorial	Description
9		<p>Wheel Load 1635 kg/ 3600 lb.</p> <p>Indicates rated wheel load.</p>
10		<p>Wheel Specifications</p> <p>Refer to manual for wheel type, offset, pressure and torque.</p>
11		<p>Forklift Pocket</p> <p>Insert fork fully into pocket to lift aerial platform.</p>
12		<p>Skyjack Logo</p> <p>Small Skyjack logo - blue and red</p>
13		<p>Towing/Pushing/Winching Procedure</p> <p>Instructions for towing, pushing or winching.</p>
14		<p>“Clear”</p> <p>Keep clear.</p>
15		<p>Emergency Lowering Procedure</p> <p>In case of emergency, follow procedure outlined in label to lower the platform.</p>

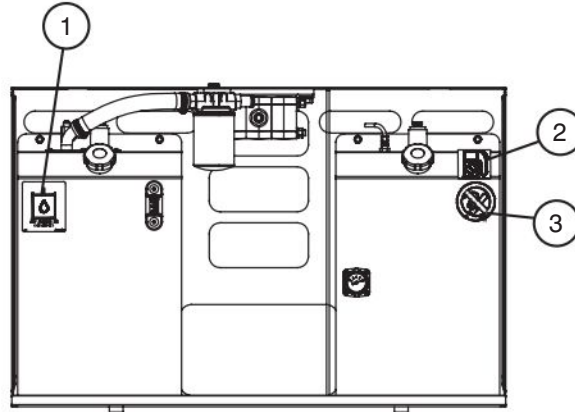

No.	Label Pictorial	Description
16		4x4 Product identifier - 4 wheel drive
17		Connect AC Supply Connect AC supply here.
18		Connect Air Supply Connect platform air supply here.
19		Tape - Red/Blue/Red Skyjack pinstripe
20		Model Number* Product Identifier *Model number will vary, may not be as shown.
21		Railing Pins (Vertical) WARNING! Falling Hazard. Ensure hinged railing is pinned.

Hydraulic/Fuel Compartment







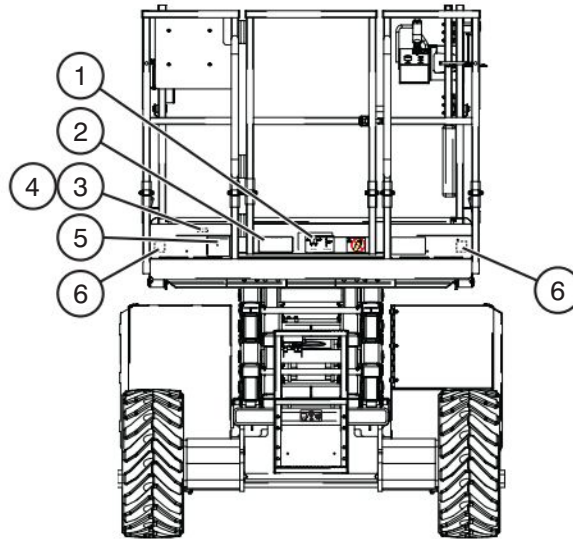

No.	Label Pictorial	Description
1		<p>Hydraulic Oil ATF Dexron III</p> <p>Replace hydraulic fluid with ATF Dexron III only.</p>
2		<p>Diesel</p> <p>Use diesel fuel only.</p>
		<p>Unleaded Fuel</p> <p>Use unleaded gasoline only.</p>
3		<p>No Smoking</p> <p>Do not smoke near this location.</p>

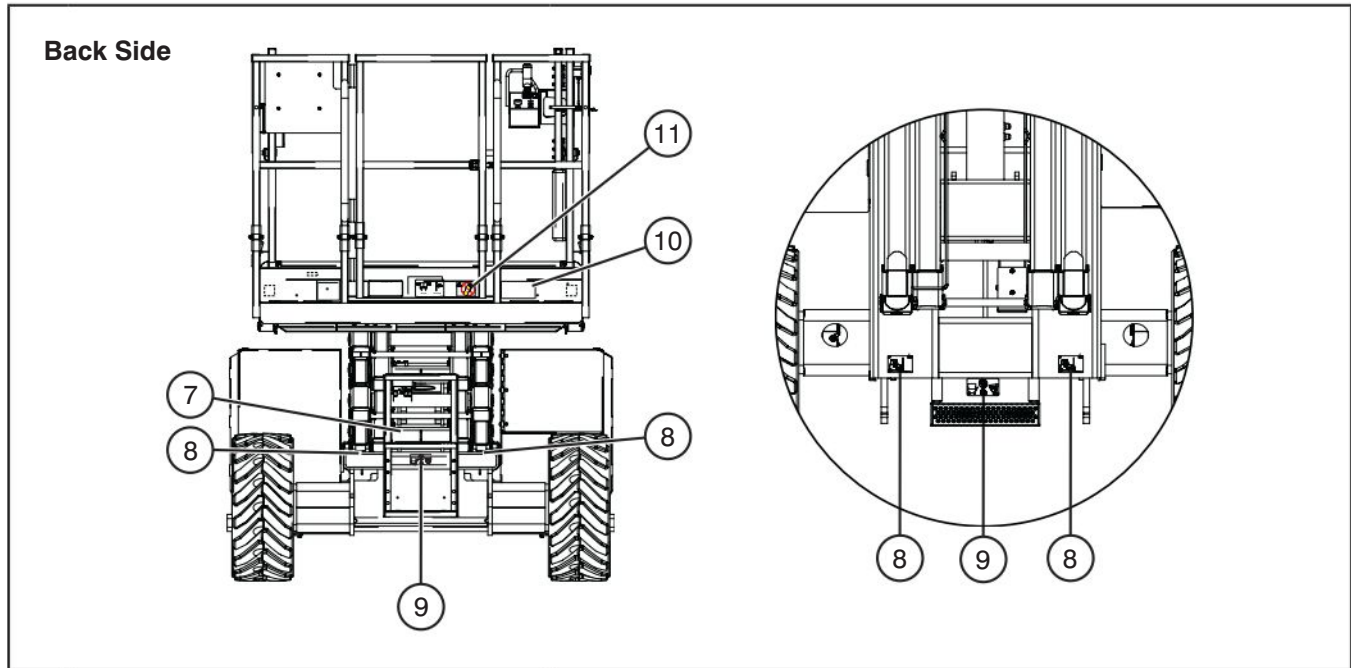
Back Side



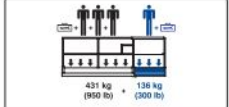
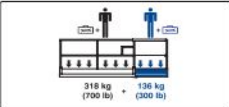

No.	Label Pictorial	Description
1		<p>Horizontal Load Rating</p> <p>Apply no more than the indicated side load. Operate below indicated wind speed only.</p>
2		<p>Standards Compliance</p> <p>Indicates standards to which the work platform complies.</p>
3		<p>Connect AC Supply</p> <p>Connect AC supply here.</p>
4		<p>Connect Air Supply</p> <p>Connect platform air supply here.</p>
5		<p>Operator's checklist</p> <p>Operator's checklist. Perform check prior to use.</p>
6		<p>Harness Anchorage</p> <p>Anchor safety belt/harness tethers here.</p>



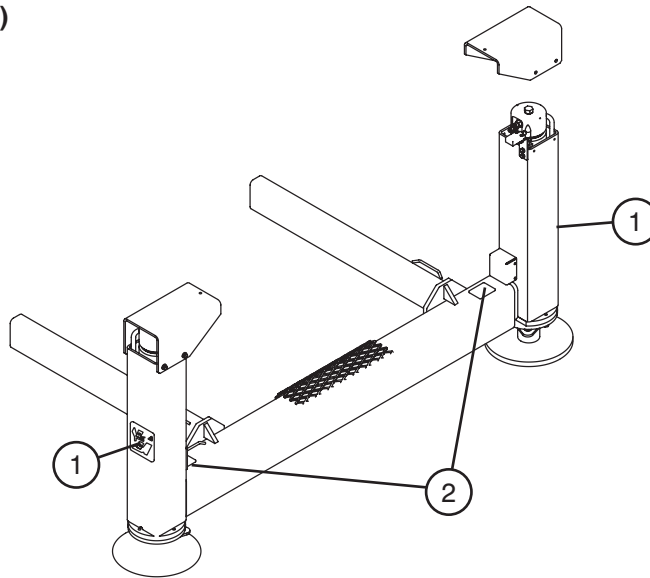

No.	Label Pictorial	Description
7		<p>Warning - Do Not Alter</p> <p>Aerial platform altering warning</p>
8		<p>Forklift Pocket</p> <p>Insert fork fully into pocket to lift aerial platform.</p>
9		<p>Lift and Tie Down Points</p> <p>Only use these points for lifting or tying down.</p>
10		<p>Platform Capacity</p> <p>Platform capacity label for 6826RT and 6832RT respectively</p> <p>Rated work load in each configuration is as shown. Rated work load includes the weight of both personnel and material. Maximum number of people in each configuration is as shown. Do not exceed total weight or maximum number of people. Load platform uniformly.</p>
		
11		<p>No Jewelry</p> <p>Caution - Do not wear jewelry.</p>

Outriggers (If Equipped)

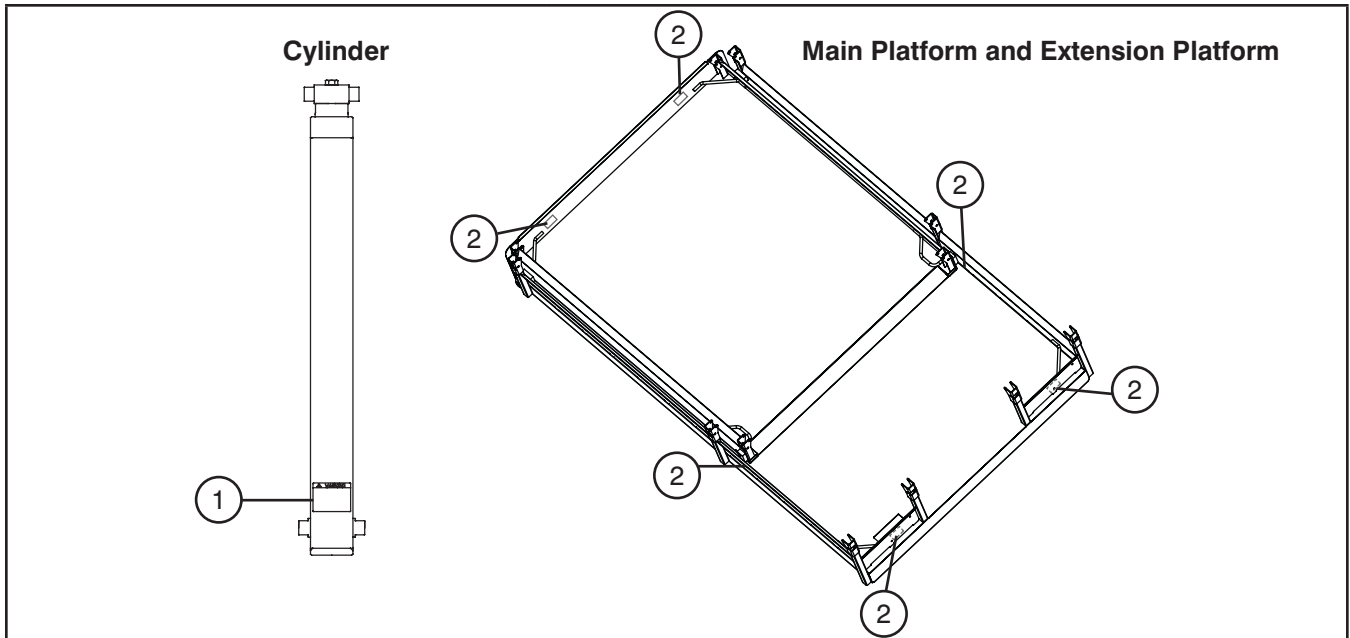

No.	Label Pictorial	Description
1		<p>Crushing Hazard Danger - Crushing hazard</p>
2		<p>Warning - Do Not Alter Aerial platform altering warning</p>

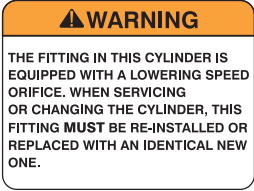

No.	Label Pictorial	Description
1		<p>Orifice Installed</p> <p>Orifice installation warning</p>
2		<p>Harness Anchorage</p> <p>Anchor safety belt/harness tethers here.</p>

Platform Control Console

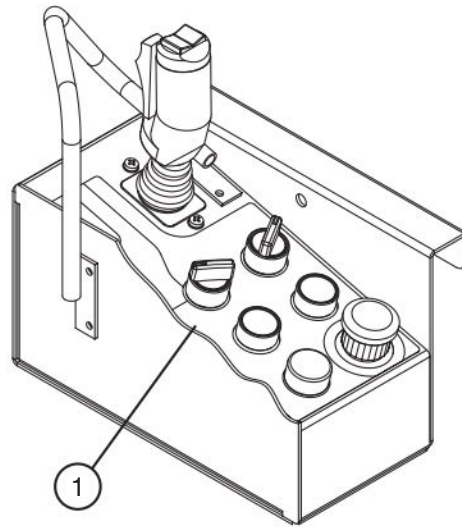

No.	Label Pictorial	Description
1		<p>Platform Control Console 68xxRT</p> <p>Squeeze “” trigger to enable controller.</p> <p>Operate “” rocker switch to steer.</p> <p>Move controller forward “” to raise or backward “” to lower platform.</p> <p>Move controller forward “” to drive forward or backward “” to drive reverse.</p> <p>Select either “” lift mode, “” drive mode with low speed (high torque) or “” drive mode with high speed (low torque).</p> <p>Select either “” low or “” high engine throttle speed.</p> <p>Push and hold “” to start engine.</p> <p>Push and hold “” to operate choke (dual fuel) or “” glow plugs (diesel).</p> <p>Push “” to sound horn.</p> <p>Push “” to stop engine and disable controls (Emergency Stop).</p> <p>Light indicates controls enabled.</p> <p>Read operating manual. </p>

Outrigger Control Console (If Equipped)

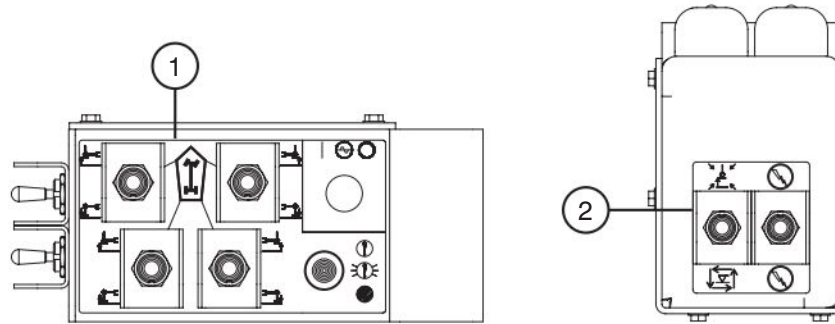

No.	Label Pictorial	Description
1		<p>Manual Outrigger Control Console with Generator</p> <p>Select “” retract or “” extend for each outrigger.</p> <p>Select “” to enable or “” to disable generator.</p> <p>Indicates leveling system status:</p> <ul style="list-style-type: none"> Off: The outriggers are fully retracted. Flashing Rapidly: The outriggers are extending but the platform is not level. Flashing: The outriggers are extended but the platform is not yet level. Solid: The outriggers are extended and the platform is level.
2		<p>Automatic Outrigger Control Console</p> <p>Select “” to retract all outriggers or “” to extend all outriggers with automatic leveling.</p> <p>Select “” to enable manual or automatic outrigger controls.</p>



Reliable lift solutions by people who care.

www.skyjack.com